

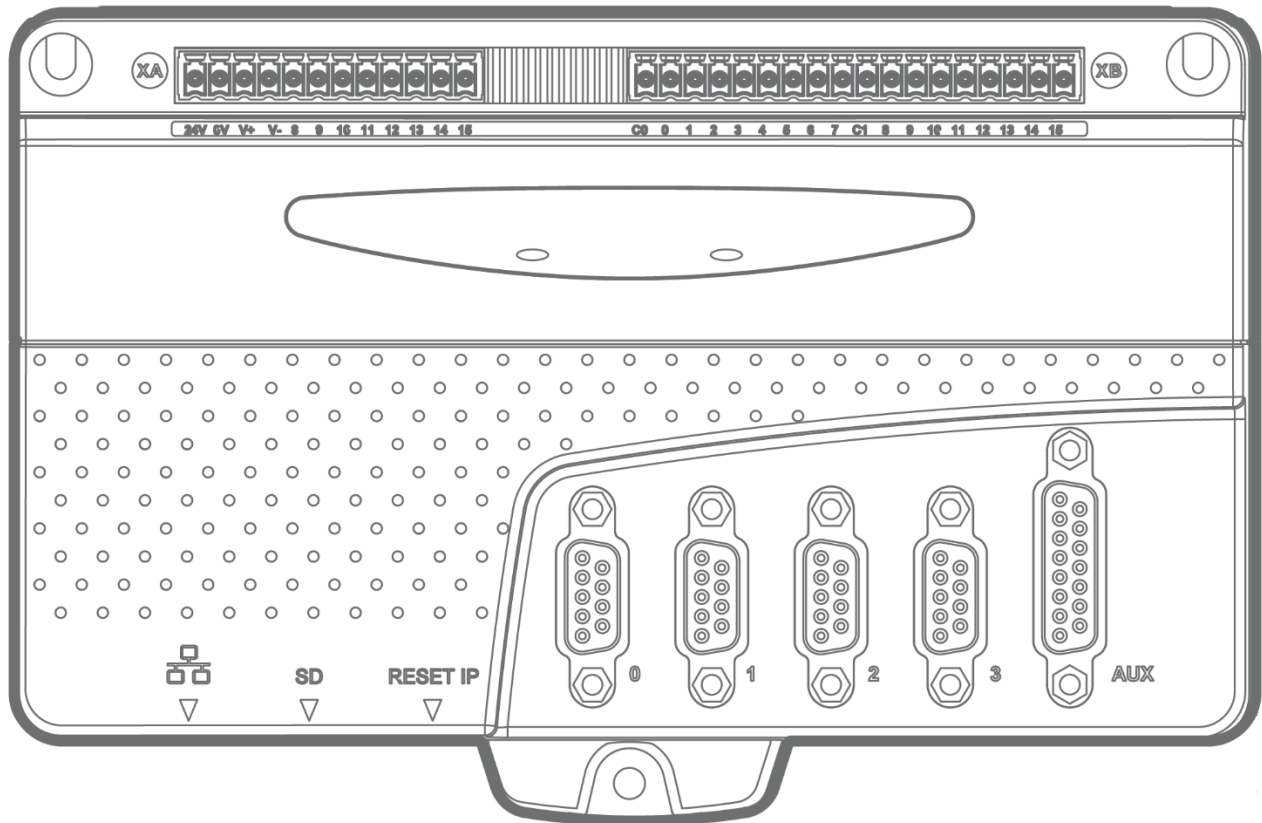

A MEMBER OF THE ESTUN GROUP



MC404-Z

4 AXIS MOTION COORDINATOR

USER MANUAL

About this Manual

Purpose

This manual provides the information required for the Selection, Wiring, Connection, Setup, Operation and Functions of the MC404-Z Motion Coordinator.

Please read and understand this manual to ensure correct usage of the product.

Terms

Terms that may be used in this manual are defined as follows.

Term	Meaning
Axis	A software control that operates a Servo or Stepper Motor.
Drive	A Servo or Stepper Drive, which is used for controlling the Motor.
Servo System	A Servo Control System that includes a Motor, a Drive, a host controller (Motion Coordinator) and peripheral devices.
WDOG ON	Closing a solid-state relay to signal that the Drives may be Enabled.
WDOG OFF	Open the solid-state relay to signal that the Drives must be Disabled.
Motion Perfect	The PC Tool for commissioning and programming the Trio product suite.
Pulse+Direction	An electronic output from the Motion Coordinator that produces one pulse per step of the motor position, with a second output to signal the direction of motion.

Revision History

Date	Version	Revised Contents
10 Nov 2020	1.00	Draft
12 Nov 2020	1.01	Update 1 - minor edits
27 Nov 2020	1.02	Update 2 - added EMC section and panel mount dimensions
22 Dec 2020	1.03	Updated product comparison table
28 May 2021	1.04	Added AOUI and absolute encoder information to specifications
28 Jun 2021	1.05	New section for Firmware Recovery procedure

All goods supplied by Trio are subject to Trio's standard terms and conditions of sale.
This manual applies to systems based on the Motion Coordinator MC404-Z.

The material in this manual is subject to change without notice. Despite every effort, in a manual of this scope errors and omissions may occur. Therefore, Trio Motion Technology Ltd. cannot be held responsible for any malfunctions or loss of data as a result.

Copyright (C) 2020-21 Trio Motion Technology Ltd.
All Rights Reserved

UK

Trio Motion Technology Ltd.
Phone: +44 (0)1684 292333

USA

Trio Motion Technology LLC.
Phone: + 1 724 472 4100

CHINA

Trio Shanghai
Tel: +86 21 587 976 59

INDIA

Trio India
Phone: +91 827 506 5446

Safety Warning



During the installation or use of a control system, users of Trio products must ensure there is no possibility of injury to any person, or damage to machinery.

Control systems, especially during installation, can malfunction or behave unexpectedly.

Users must ensure that in all cases of normal operation, controller malfunction, or unexpected behaviour, the safety of operators, programmers or any other person is totally ensured.

Contents

Revision History	2
User Manual MC404-Z.....	7
Overview	7
Programming.....	7
I/O Capability.....	7
Communications.....	8
IP Address reset	8
Removable storage.....	8
Axis positioning functions.....	8
LED indicators	9
Connections to the MC404-Z.....	9
Serial connections	9
CANbus connections.....	9
Amplifier enable (Watchdog) relay output	10
Analogue I/O	10
Axis ports	10
Registration	12
I/O connector 1.....	12
I/O connector 2.....	12
Auxiliary connector	13
Grounding and Shielding.....	13
Connection example 1	14
Connection example 2	14
Software	15
Motion Perfect version 5	16
Firmware.....	18
Firmware recovery	18
Dimensions	18
Mounting.....	19
Specifications	19
Product Comparison Table.....	21

Electromagnetic Compatibility..... 24

 Intended conditions of use 24

 EMC Considerations 24

 Product specific requirements 24

 Recommended Installation..... 26

 Surge Protection..... 26

 Surge protection device 27

 Cable Shields..... 28

User Manual MC404-Z

Overview

The Motion Coordinator MC404-Z is based on Trio's high-performance ARM Cortex-M7 double-precision technology and provides 4 axes of pulse+direction or quadrature output control for stepper drives or pulse-input servo drives. Trio uses advanced FPGA techniques to reduce the size and fit the pulse output and servo circuitry in a compact panel mounted package. The MC404-Z is housed in a rugged plastic case with integrated earth chassis and incorporates all the isolation circuitry necessary for direct connection to external equipment in an industrial environment. Filtered power supplies are included so that it can be powered from the 24V d.c. logic supply present in most industrial cabinets.



It is designed to be configured and programmed for the application using a PC running Trio's Motion Perfect application software, and then may be set to run "standalone" if an external computer is not required for the final system. Programs and data are stored directly to FLASH memory, thus eliminating the need for battery backed storage.

The Multi-tasking version of Motion-iX for the MC404-Z allows up to 10 Motion-iX programs to be run simultaneously on the controller using pre-emptive multi-tasking. In addition, the operating system software includes the IEC 61131-3 standard run-time environment that has access to the full library of motion functions.

Programming

The Multi-tasking ability of the MC404-Z allows parts of a complex application to be developed, tested and run independently, although the tasks can share data and motion control hardware. The 6 available tasks can be used for Motion-iX or IEC 61131-3 programs, or a combination of both can be run at the same time, thus allowing the programmer to select the best features of each.

I/O Capability

The MC404-Z has 16 built in 24V inputs that can be configured as either source or sink in banks of 8, and 8 sinking NPN 24V outputs. These may be used for system interaction or may

be defined to be used by the controller for end of travel limits, registration, datuming and feedhold functions if required. The MC404-Z can have up to 512 external Input and Output channels connected using DIN rail mounted CAN I/O modules. These units connect to the built-in CANbus port.

Communications

A 10/100 base-T Ethernet port is fitted as standard and this is the primary communications connection to the MC404-Z. Protocols supported include Telnet (Client and Server), Modbus TCP (Client and Server), Ethernet IP (Client) and the TrioPCMotion DLL/ActiveX channel.

The MC404-Z has one built in RS232 port and one built in duplex RS485 channel for simple factory communication systems. Either the RS232 port or the RS485 port may be configured to run the Modbus or Hostlink protocol for PLC or HMI interfacing.

If the built-in CAN channel is not used for connecting I/O modules, it may optionally be used for CAN communications. E.g. DeviceNet, CANopen etc.

IP Address reset

To reset the IP _ ADDRESS, IP _ GATEWAY and IP _ NETMASK to their default values press the IP reset button located next to the SD card slot and power cycle the controller while keeping the button pressed.

The factory default IP address is 192.168.0.250. This can be changed using the ETHERNET or IP_ADDRESS commands via Motion Perfect.

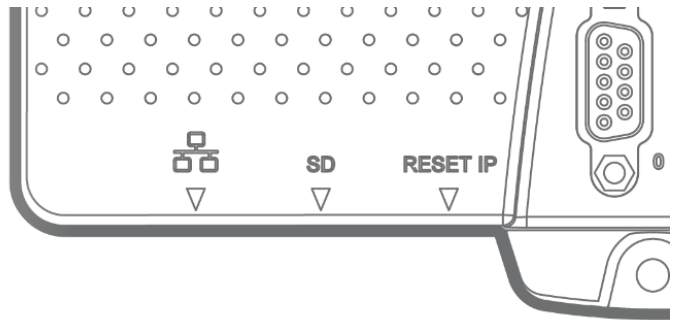

Removable storage

The MC404-Z has a micro-SD Card slot which allows a simple means of transferring programs, firmware and data without a PC connection. Offering the OEM easy machine replication and servicing.

The memory slot is compatible with a wide range of micro-SD cards up to 32 GBytes using the FAT32 compatible file system.



Axis positioning functions

The motion control generation software receives instructions to move an axis or axes from the Motion-iX or IEC 61131-3 language which is running concurrently on the same processor. The motion generation software provides control during operation to ensure smooth, coordinated movements with the velocity profiled as specified by the controlling program. Linear interpolation may be performed on groups of axes, and circular, helical or spherical interpolation in any two/three orthogonal axes. Each axis may run independently, or they may be linked using interpolation, electronic gearboxes and simple kinematics.

Consecutive movements may be merged to produce continuous path motion and the user may program the motion using programmable units of measurement (e.g. mm, inches, revs etc.). The module may also be programmed to control only the axis speed. The positioner checks the status of end of travel limit switches which can be used to cancel moves in progress and alter program execution.

LED indicators

2 LEDs show the status of the power and the enable circuit. The enable circuit drives the watchdog relay and activates the pulse output signals.

Red LED ON shows that the WDOG is off and the axes are disabled. When the red LED is OFF, the axes are enabled and ready to move. A flashing red LED indicates that one or more axes are in error.

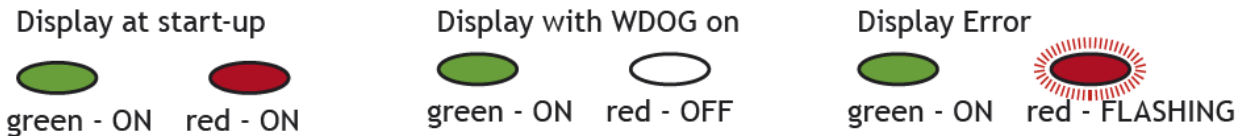

Connections to the MC404-Z

Ethernet port connection

RJ45 socket 10/100 base_T

The Ethernet port is the default connection between the Motion Coordinator and the host PC running the Motion Perfect development application.



Serial connections

The MC404-Z features two serial ports. Port 1 is a standard RS232 serial connection and Port 2 is configurable as RS422 or RS485 by external wiring. Both ports are accessed through the 15-way auxiliary connector.

The serial ports are not isolated therefore the 0V terminal MUST be connected.

CANbus connections

A CANbus port for connection to Trio’s digital and analogue CAN I/O expansion modules is provided on the auxiliary connector. CAN-H on pin7 and CAN-L on pin 15.

The CANbus port is not isolated therefore the 0V terminal MUST be connected.

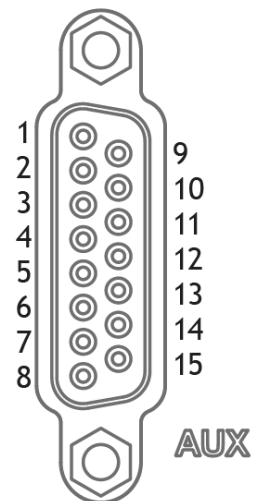

Amplifier enable (Watchdog) relay output

An internal solid-state relay contact is available to enable external drives when the controller has powered up correctly and the system and application software are ready. The amplifier enable relay has an ON resistance of 25Ω at 100mA. The enable relay will be open circuit if there is no power on the controller OR a motion error exists on an axis OR the user program sets it open with the WDOG = OFF command.

The amplifier enable relay may, for example, be incorporated within a hold-up circuit or safety relay circuit that must be intact before torque is applied to motor windings.

Analogue I/O

The 15-way auxiliary connector includes a single built-in 12 bit analogue input with a scale of 0 to 10V. A 10 bit, 0 to 10V analogue output is also provided for general use. For example, to send a control voltage to an open-loop inverter drive.

Axis ports

The MC404-Z is designed to support pulse driven motor drives on the standard controller hardware. All 4 axes are available as standard and no additional axis feature enable codes are required. In addition, axis 3 can be configured as an encoder input for systems that need a master encoder reference.

Each of the axes (0-3) may be enabled as pulse+direction or quadrature AB output according to the user’s requirements by setting the axis ATYPE parameter. **Axis 3 only** can be set as either pulse output, encoder output or encoder input.

The function of the 9-pin ‘D’ connectors will be dependent on the specific axis configuration which has been defined. If the axis is configured as a pulse output, the connector provides differential outputs (RS422) for step+direction or simulated encoder, and enable signals. If axis 3 is set as encoder input, there is an input for the Z channel as well as A and B. The Z can be used for position registration capture.

The 9-way socket for axis 3 provides a current-limited 5V output capable of powering most encoders. This simplifies wiring and reduces the need for external power supplies.

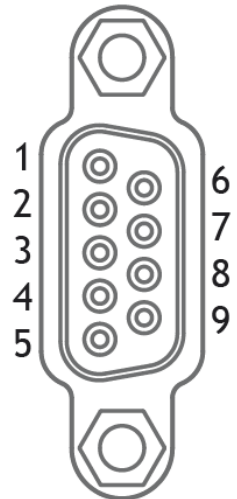

Axis 0, 1 and 2

RS422 line driver output for Step, Direction and Enable signals or alternatively can be set for A, B and Enable.

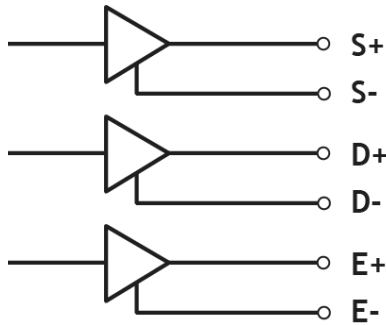

RS422 Line Driver

Pin #	Description
1	Step + / A +
2	Step - / A -
3	Direction + / B +
4	Direction - / B -
5	0V
6	Enable +
7	Enable -
8	No connection
9	No connection

Axis 3

RS422 line driver / receiver. Output for Step, Direction and Enable or A, B and Enable. Inputs for A, B and Z incremental encoder or Clock and Data absolute encoders.

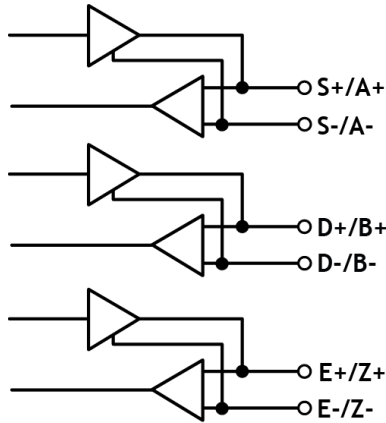

RS422 Line Transceiver

Pin #	Output	AB Enc In	Absolute Enc In
1	Step + / A +	A +	Clock +
2	Step - / A -	A -	Clock -
3	Direction + / B +	B +	No Connection
4	Direction - / B -	B -	No Connection
5	0V		
6	Enable +	Z +	Data +
7	Enable -	Z -	Data -
8	+5V 150mA out		
9	No connection		

Registration

MC404-Z encoder port has 2 available registration events. These are assigned in a flexible way to any of the first 8 digital inputs or can be used with the Z mark input on the encoder port.

I/O connector 1

This connector is used both to provide the 24 Volt power to the MC404-Z and provide power and connections for the 24V NPN outputs. The 24 Volt main supply input is internally isolated from the I/O 24 Volts.

A 24V d.c., Class 2 transformer or power source required for UL compliance. The MC404-Z is grounded via the metal chassis. It MUST be installed on an unpainted metal plate which is connected to earth. An earth connection screw should be applied to the lower mounting point for bonding the MC404-Z to ground.

24V Output channels (NPN)

Output channels 8..15 are NPN sinking outputs. The output circuit has electronic over-current protection and thermal protection which shuts the output down when the current exceeds 500mA.

Care should be taken to ensure that the 500mA limit for each output circuit is not exceeded, and that the total load for the group of 8 outputs does not exceed 4 Amps.

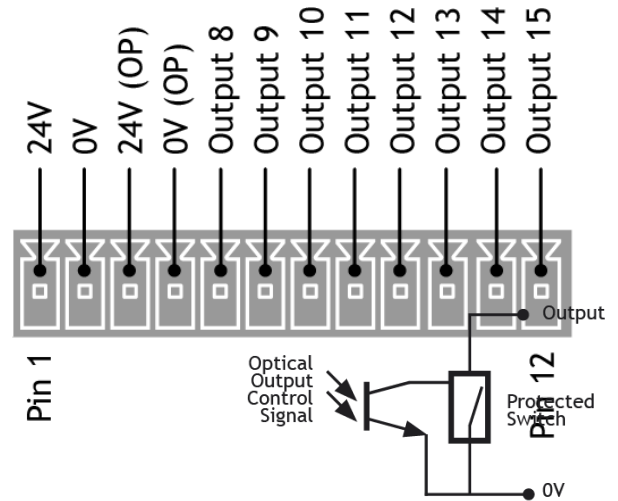

I/O connector 2

24V Input channels (PNP / NPN)

16 channels of 24V digital inputs are provided in 2 banks of 8. Each set of 8 inputs has a common connection which determines the mode of the inputs.

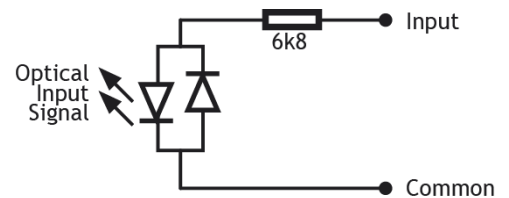
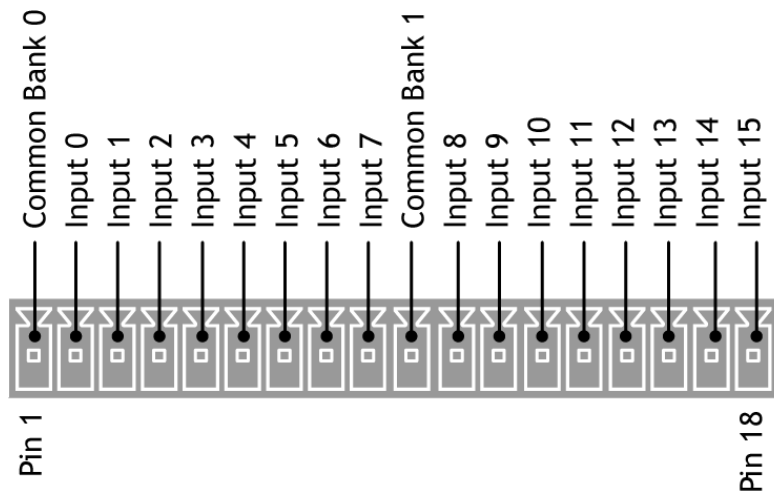

If the common is connected to 0V then the 8 inputs are PNP and a 24V source signal will set the input ON.

When the common is connected to 24V, the inputs are NPN and the source signal must be a path to 0V for the ON condition.

Inputs 0 to 7 can be used as registration inputs allocated by REG_INPUTS for axis 3, using the REGIST command.

Auxiliary connector

The 15 way D-Type connector is a multi-function socket that has 1 x RS232 port, 1 x RS422/RS485 port, 1 x CANbus port, Analogue I/O and connections for the WDOG solid-state relay.

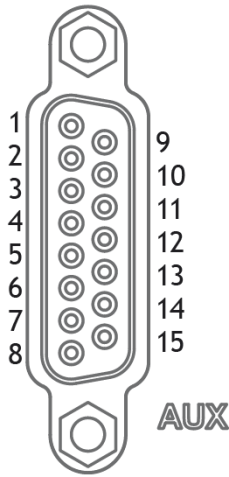

Pin #	Description	Pin #	Description
1	RS232 Transmit	9	RS232 Receive
2	RS485 Data In A (Rx+)	10	RS485 Data In B (Rx-)
3	RS485 Data Out Y (Tx+)	11	RS485 Data Out Z (Tx-)
4	0V	12	0V
5	AIN (Analogue Input)	13	AOUT (Analogue Output)
6	WDOG-A	14	WDOG-B
7	CAN High	15	CAN Low
8	0V		

Grounding and Shielding

Good quality screened cables should be used for the auxiliary port. The serial ports and CANbus port are not galvanically isolated, therefore the 0V return MUST be connected to all peripheral devices. In addition, bond together the 0V (24V return) terminals of all system components to minimise current flowing in the serial cables.

Ensure that:

1. 0V connection is NOT used for terminating screens.
2. For fully opto-isolated inputs on the drive, the 0V may be ommitted.
3. Screen should be connected to the 9 or 15 way D-type shell.
4. The MC404-Z 24V supply has common 0V with the drive(s).

Connection example 1

Stepper drives.

All outputs are RS422 differential line drivers rated at 5V 10mA.

The 0V may be omitted if the stepper drive inputs are fully opt0-isolated.

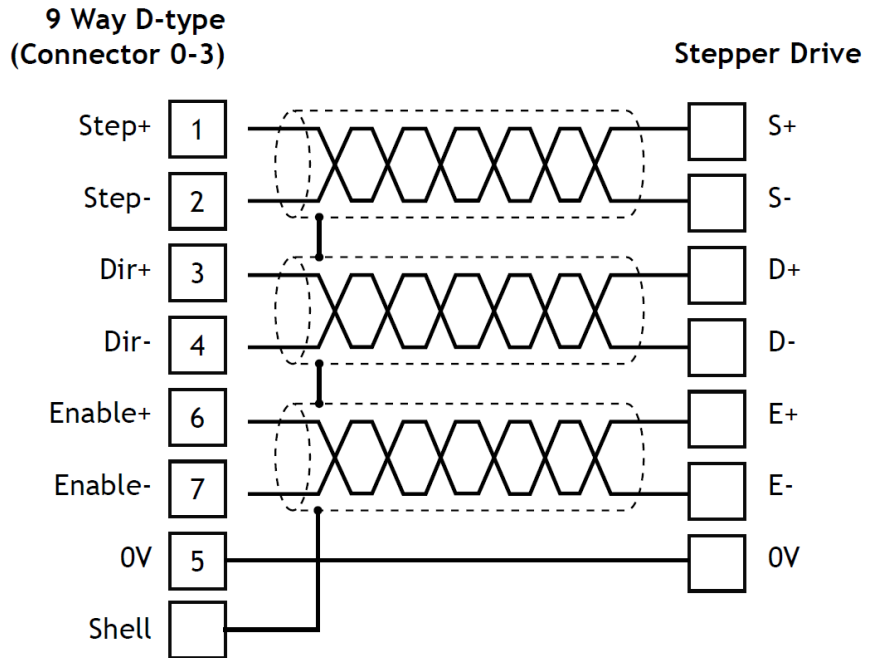

Connection example 2

Servo drives with 24V enable

Many Servo drives that have pulse and direction inputs for motion also use a 24V enable input. The WDOG connection, pins 6 and 14 on the Auxiliary connector can be used to directly enable the drives. The same signal can be used to enable all 4 axes.

A risk assessment must be done to decide if any of the motors that are controlled by the MC404-Z might cause harm to an operator. The MC404-Z WDOG and Enable outputs are NOT Safety outputs. An additional safety circuit may be needed to comply with regulations.

The WDOG signal may be connected to multiple drive enable inputs.

WDOG-A and WDOG-B are a volt-free solid-state relay. They may be used with +24V on either terminal.

9 Way D-type (Connector 0-3)

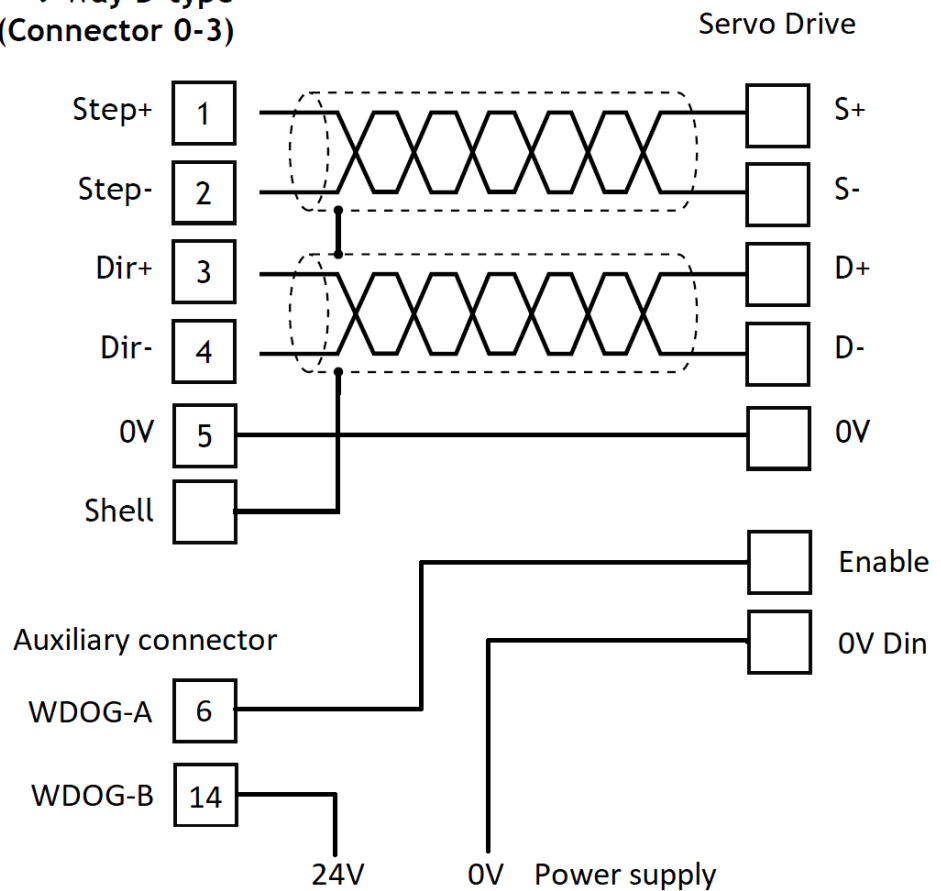

Software

Motion Perfect version 5 or later is required for configuring, programming and system debug. A PC running Microsoft Windows (Windows 10 or later recommended) is required. Download Motion Perfect from www.triomotion.com and install on the PC.

Connection is via the Ethernet port. Ensure that the PC has a valid Ethernet Address. For single point-to-point connection, a fixed IP address must be set in the PC. Go to Settings, Network and Internet then open Change Adapter Settings. Open the Ethernet port.

Click the Properties button and then select Internet Protocol Version 4 (TCP/IPv4).

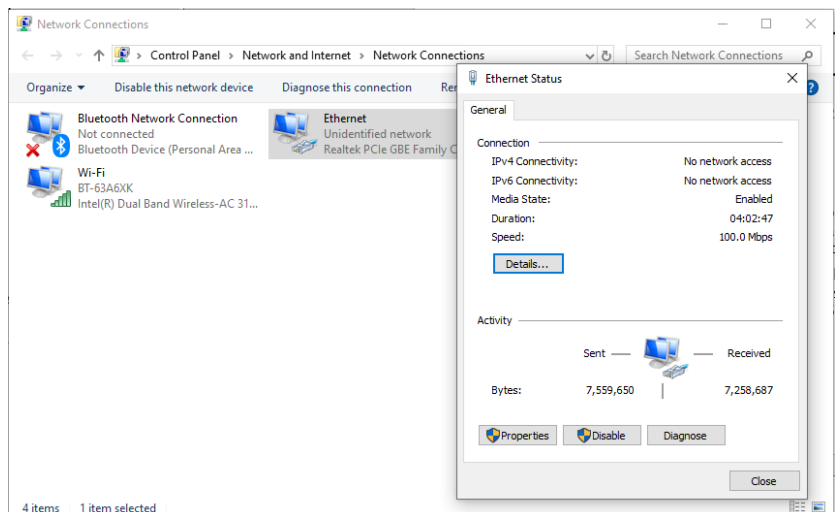

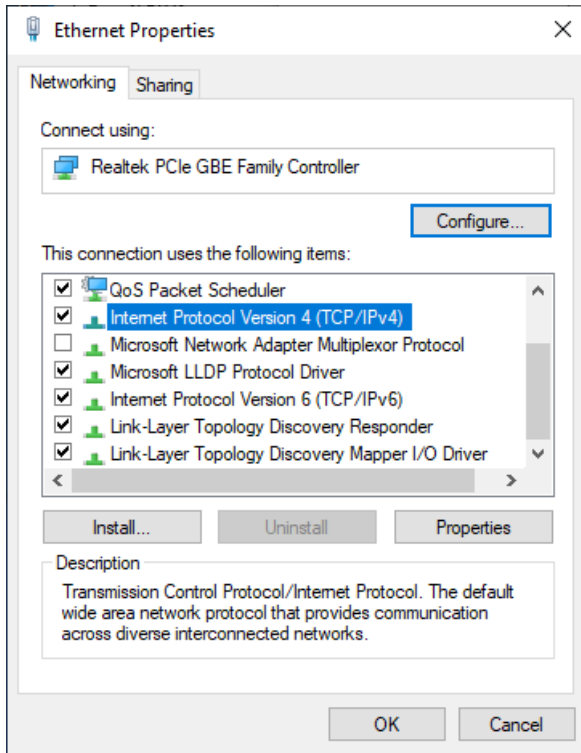

Click Properties and select Use the following IP address. Set an IP address in the same subnet as the MC404-Z. Usually this will be 192.168.0.xxx.

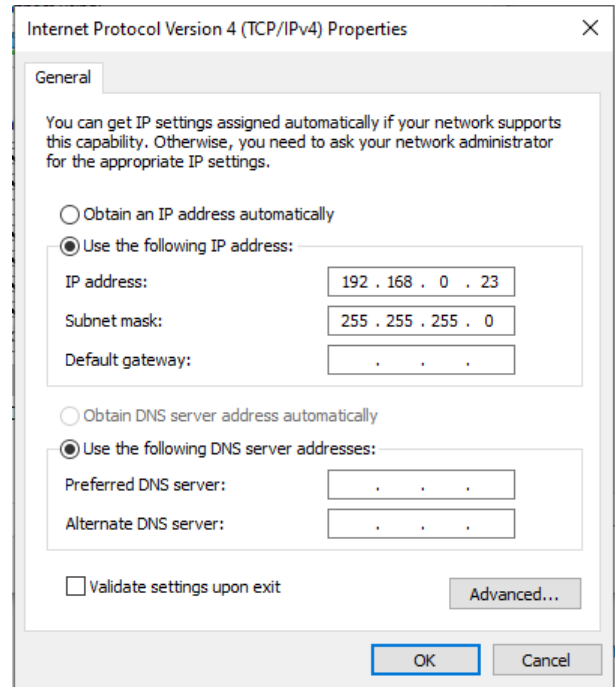

Click OK and close the Ethernet setup dialogues.

Motion Perfect version 5

Launch Motion Perfect and select the IP address of the MC404-Z. By default this will be 192.168.0.250. Click the Apply and Connect button.

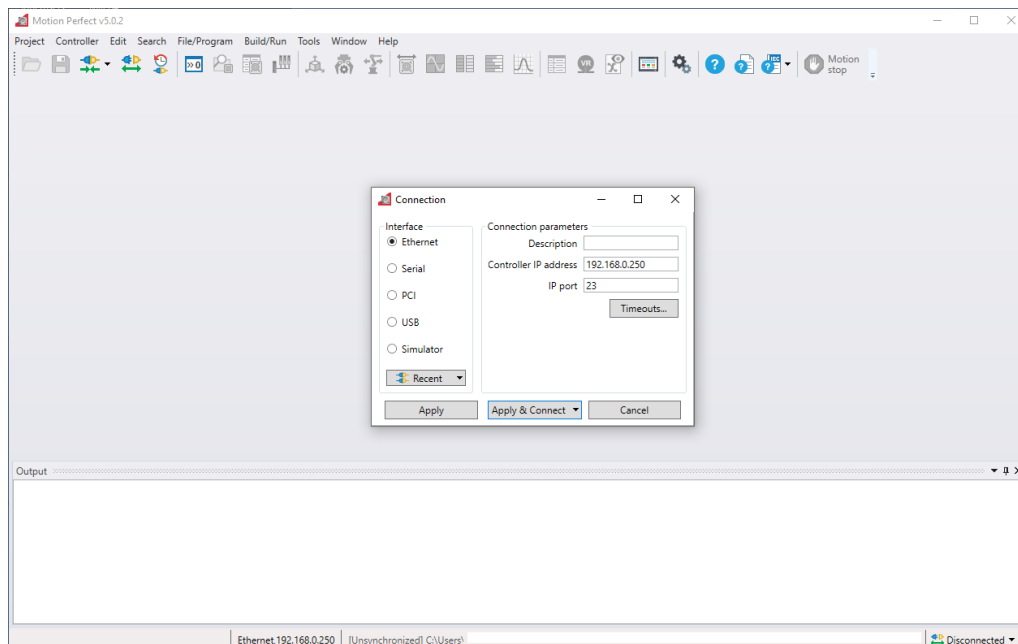

If the IP Address of the MC404-Z is not known, then reset it by holding the IP Reset button located next to the SD card slot while powering up the MC404-Z. This will reset the IP_ADDRESS to 192.168.0.250.

Motion Perfect in Synchronised connection mode.

The screenshot displays the Motion Perfect v5.0.2 software interface. The top menu bar includes Project, Controller, Edit, Search, File/Program, Build/Run, Tools, Window, and Help. The main window is divided into several sections:

- Controller Panel:** Shows 'MC404-Z (P855) v2.0304' with 'Axis Status: OK' and 'System: OK'. It includes buttons for 'Reset MC', 'Motion stop', 'Master enable', and 'Halt programs'.
- Programs List:** A tree view showing programs: ROTARY_KNIFE, START_CONVEYOR, STOP_CONVEYOR, and MC_CONFIG, each with status icons.
- Digital I/O Status:** A table showing inputs (0-15) and outputs (8-15).
- Axis Parameters Table:** A detailed table for 'ROTARY_KNIFE' showing parameters for Axis (0), Axis (1), and Axis (2).

Parameter	Axis (0)	Axis (1)	Axis (2)
ATYPE	Step+Dir	Step+Dir	Step+Dir
UNITS	1	1	1
Velocity profile			
ACCEL	10000	10000	10000
DECEL	10000	10000	10000
SPEED	1000	1000	1000
CREEP	100	100	100
JOGSPEED	100	100	100
MSPEED	0	0	0
VP_SPEED	0	0	0
Limits			
FHOLD_IN	-1	-1	-1
FWD_IN	-1	-1	-1
REP_DIST	200000000000	200000000000	200000000000
REP_OPTION	0	0	0
REV_IN	-1	-1	-1
FS_LIMIT	400000000000	400000000000	400000000000
RS_LIMIT	-400000000000	-400000000000	-400000000000
Positions			
DPOS	0	0	0
ENDMOVE	0	0	0
MPOS	0	0	0
REMAIN	0	0	0
Axis output			
AXIS_ENABLE	1	1	1
SERVO	0	0	0
Status			
AXISSTATUS	None	None	None
MOVE_COUNT	0	0	0
LINK_AXIS	-1	-1	-1
MTYPE	Idle	Idle	Idle
NTYPE	Idle	Idle	Idle
Jogging			
FAST_JOG	-1	-1	-1
FWD_JOG	-1	-1	-1
REV_JOG	-1	-1	-1

The MC404-Z is capable of running up to 16 axes total including virtual axes, of which 4 are real axes. Up to 6 program processes may be run at any time. (0 to 5)

Firmware

The MC404-Z comes pre-installed with the firmware version which was released to production at the time of manufacture. Newer versions may be available to download from the Trio website and it is recommended to check if an update is available before using the Motion Coordinator for an application.

New firmware can be installed using Motion Perfect. Click the Controller menu and select *Load Firmware* The firmware file must be extracted from the zip folder before it can be used. Firmware file names start MC404Z_ and have the extension .out. Do not attempt to load firmware designed for a different Motion Coordinator type.

Firmware recovery

Firmware can be re-installed without using Motion Perfect by adding the firmware file to a micro SD card so that the MC404-Z will automatically re-load the firmware at power-on.

Format the micro SD card to FAT 32, rename the firmware file to r_406.out and copy the file on to the SD card. Insert the card into the slot on the Motion Coordinator and power up. The Red LED will flash during the firmware loading process. When the Red LED becomes steady it will be possible to re-connect to the MC404-Z via Ethernet.

All applications programs will be deleted when the new firmware is installed

Dimensions

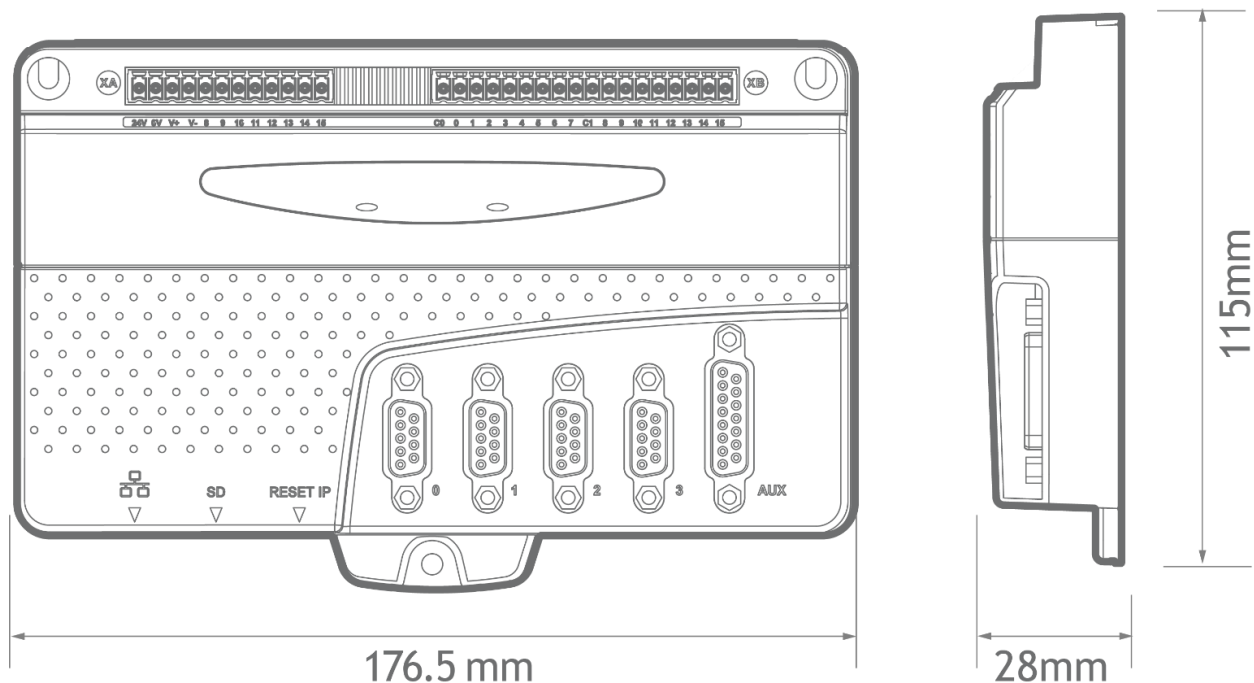

Mounting

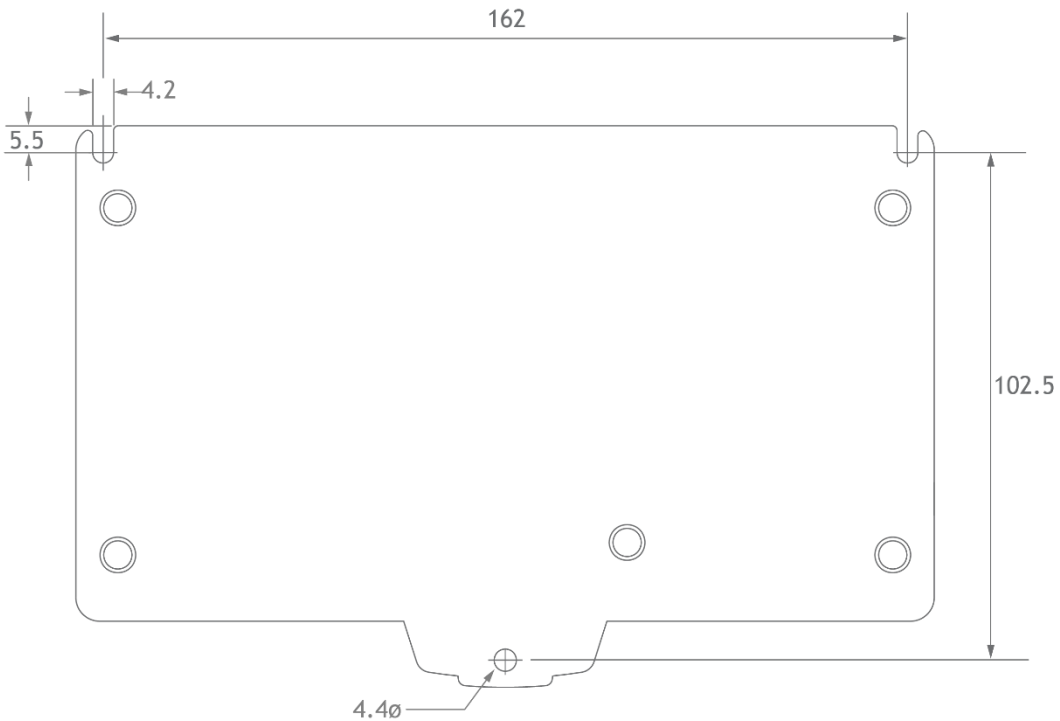

2 x upper slots 4.2 mm width. 1 x lower mounting hole 4.4 mm dia.

Ventilation: When the MC404-Z is mounted in an enclosed cabinet, there must be an adequate volume of circulating air to maintain the environmental temperature within the operating temperature range. If clearance is allowed for cable connections, there is no further limit on spacing next to other components that do not emit heat.

Place below heat sources such as drives and power supplies.

Specifications

Specification table	
Size	176.5 mm x 115 mm x 28 mm (HxWxD)
Weight	430g
Operating Temp.	0 - 45 degrees C
EMC (CE)	EMISSIONS - EN61000-6-4 : 2019 IMMUNITY - EN61000-6-2 : 2019

Control Inputs (user selectable)	Forward Limit Reverse Limit Datum Input Feedhold Input
Communication Ports	RS232 channel: up to 128k baud. RS485 channel: up to 128k baud CANbus port (CANopen option) Ethernet: 10/100 BaseT multiple port connection.
Position Resolution	64 bit position count
Speed Resolution	32 bits. Speed may be changed at any time Moves may be merged
Servo Cycle	125µs minimum 1ms default 4ms max
Programming	Multi-tasking Motion iX system IEC 61131-3 programming system. Maximum 6 user processes.
Interpolation modes	Linear 1-4 axes, circular, helical, spherical, CAM Profiles, speed control, software gearbox and linked motion
Memory	3 Mbyte user program memory Automatic flash EPROM program and data storage
VR	4096 global VR data in FLASH memory (automatic-store)
TABLE	512000 x 64 bit TABLE memory
Real Time Clock	Super-capacitor maintained power supply for up to 10 days of power off
SD Card	Standard micro-SD Card FAT 32, up to 32 GB Stores programs and data Can be used for firmware update and user program install
Power Input	24V d.c. +/- 20%. Class 2 transformer or power source 18..29V d.c. at 350mA + IO supply

Amplifier Enable Output	Normally open solid-state relay rated 24V ac/dc nominal Maximum load 100mA Maximum Voltage 29V
Analogue Inputs	1 x 12 bit 0 .. 10V
Analogue Outputs	1 x 10 bit 0 .. 10V. Response time 30 msec to 90% of value.
Step+direction output	RS422 differential line driver Max frequency 2MHz
Encoder input (Axis 3)	RS422 differential line receiver / line driver Incremental encoder max edge rate 6Mhz Absolute encoders; SSI, EnDat, Tamagawa and Biss
Encoder Power Output	5V at 150mA
Digital Inputs	16 Opto-isolated 24V inputs NPN / PNP in banks of 8
Digital Outputs	8 Opto-isolated 24V outputs Current sinking (NPN) 500 mA. (max. 4A per bank of 8)
Product Code	P855 : MC404-Z 4 axis stepper output Motion Coordinator

Product Comparison Table

Feature comparison table - Boxed Motion Coordinators up to 5 axes				
Pulse output	MC403-Z	MC403	MC405	MC404-Z
Axis 0 Pulse + Direction	Y	Y	Y	Y
Axis 1 Pulse + Direction	Y	Y	Y	Y
Axis 2 Pulse + Direction	Y	Y	Y	Y
Axis 3 Pulse + Direction			Y	Y
Axis 4 Pulse + Direction			Y	
Analogue Servo	MC403-Z	MC403	MC405	MC404-Z
Axis 0 +/- 10V out + Encoder	N	Y	Y	N
Axis 1 +/- 10V out + Encoder	N	Y	Y	N
Axis 2 +/- 10V out + Encoder	N	N	Y	N
Axis 3 +/- 10V out + Encoder			Y	N

Axis 4 +/- 10V out + Encoder			N	
Reference Encoder Input	MC403-Z	MC403	MC405	MC404-Z
Axis 0 (Inc. / SSI / Endat / BiSS)	I	I/S/E/B	I/S/E/B	N
Axis 1 (Inc. / SSI / Endat / BiSS)	I	I/S/E/B	I/S/E/B	N
Axis 2 (Inc. / SSI / Endat / BiSS)	I	I/S/E/B	I/S/E/B	N
Axis 3 (Inc. / SSI / Endat / BiSS)			I/S/E/B	I/S/E/B
Axis 4 (Inc. / SSI / Endat / BiSS)			I/S/E/B	
24V Input / Output	MC403-Z	MC403	MC405	MC404-Z
Digital Inputs (PNP)	8	8	8	
Digital Inputs (PNP / NPN)				16
Digital I/O Bi-Directional (PNP)	4	4	8	
Digital Outputs (NPN)				8
Digital Outputs (PNP)				
WDOG output solid-state relay	Y	Y	Y	Y
Analogue Inputs/Outputs	MC403-Z	MC403	MC405	MC404-Z
Analogue Input (12 bit 0..10V)	2	2	2	1
Analogue Output (12 bit +/-10V)		2	4	
Analogue Output (10 bit 0..10V)				1
Registration	MC403-Z	MC403	MC405	MC404-Z
Axes supporting registration	0/1/2	0/1/2	0/1/2/3	3
24V registration inputs	6	6	8	2
Z mark registration (encoder axes)	Y	Y	Y	Y
Serial ports	MC403-Z	MC403	MC405	MC404-Z
RS232 port #1	Y	Y	Y	Y
RS485/RS422 port #2	Y	Y	Y	Y
CANbus port	Y	Y	Y	Y
Performance	MC403-Z	MC403	MC405	MC404-Z
Minimum servo period (usec)	125	125	125	125
Maximum servo period (usec)	2000	2000	2000	4000
Multi-tasking #processes	0..5	0..5	0..9	0..5
Benchmark test (Motion iX)	40	40	40	68

VR memory	4096	4096	4096	4096
TABLE memory	512000	512000	512000	512000
User (program) memory	check	check	check	3 MB

Electromagnetic Compatibility

Trio Motion Technology products are certified to comply with the requirements of Annex I to the Directive 2014/30/EU on Electromagnetic disturbance and Electromagnetic immunity. To achieve this compliance, certain requirements or best engineering practices must be implemented by the corresponding system designer.

Intended conditions of use

Trio Motion Technology products are designed for operation in Industrial environments with high noise levels that may induce currents or electrical potentials that are damaging to microelectronics. Our products are nevertheless designed and tested to withstand the level of electromagnetic disturbance common to these environments, on the provision that the appropriate EMC guidelines have been employed by a qualified competent system integrator.

The Trio Motion Technology product range is designed to be integrated, by the customer, as a control system for industrial machines and auxiliary equipment.

EMC Considerations

Electromagnetic Interference problems can usually be avoided by careful wiring and following a few basic rules.

- Mount noise generators such as contactors, solenoid coils and relays as far away as possible from the Motion Coordinator.
- Where possible use solid-state contactors and relays.
- Fit suppressors across coils and contacts.
- Place high voltage cables in separate trunking to low voltage and signal cables.
- Ensure all the modules have a secure earth connection.
- Where screened cables are used, terminate the screen with a [360 degree termination](#) rather than a “pig-tail”. Connect both ends of the screen to earth. The screening should be continuous, even where the cable passes through a cabinet wall or connector.

These are just general guidelines and for more specific advice, see the installation requirements later in this chapter.

The consideration of EMC implications is more important than ever since the introduction of the EC EMC directive which makes it a legal requirement for the supplier of a product to the end customer to ensure that it does not cause interference with other equipment and that it is not itself susceptible to interference from other equipment.

Product specific requirements

Trio Motion’s extensive product and application knowledge combined with product testing reflect that the best immunity is achieved by placing some constraint on the system into which the product is being integrated. The information is presented in this section for the commissioning engineer.

Feature	Requirements	Notes
0V wire (current return)	<ol style="list-style-type: none"> 1. Always connect ALL 0V current return wires 2. Do not use the screen for 0V current return 3. It is highly recommended to avoid connecting 0V across internal isolation barriers. If a single 24V supply is used for the main power and IO power then these two isolated 0V will have to be connected but this should only be done if the 24V supply is free from switching noise 4. Do not join together 0V from high power and / or noisy sources with the 0V from signal ports (incl. CAN bus DC input) 5. Do not use any controller 0V connection as a current return for peripheral devices 	<p>MC404-Z stepper 0V, encoder 0V and Auxiliary connector 0V are all common together.</p> <p>24V supply 0V is isolated.</p> <p>24V IO supply is isolated.</p>
All 24V DC ports	<ol style="list-style-type: none"> 1. It is highly recommended to use surge filters on all DC supply and 0V return. If more than one device is connected to the same PSU then this is a requirement. See Surge Protection below. 	
Cable routing	<ol style="list-style-type: none"> 1. Maintain 150mm separation of parallel Class I and Class II cable (IEC 61000-5-2:1997) 2. Unless otherwise specified, all cables must be <30m in length 	
Proximity to source of disturbance	<ol style="list-style-type: none"> 1. Place controllers and expansion modules as far from mains cables, mains filters, contactors, circuit breakers, drives, transducers or other high power sources of EM disturbance as physically possible within the enclosure design. 	
Enclosure / Safety Cabinet design	<ol style="list-style-type: none"> 1. Trio's products should always be installed within a locked cabinet with access limited to authorised personnel only. 	
Differential Stepper / Encoder Signals	<ol style="list-style-type: none"> 1. Screened, twisted pair cable. 2. Connect screen to metal chassis at both ends (See Cable Shields) 3. 0V reference connected at both ends. 	
CAN bus	<ol style="list-style-type: none"> 1. Screened, twisted pair cable with characteristic impedance of 120 Ohm. (± 10 Ohm) 2. Connect screen to Chassis at every node. 	<p>Connect screen to Aux connector shell at MC404-Z.</p> <p>0V on Aux connector, pins 4, 8 and 12 are common 0V.</p>
Digital I/O	<ol style="list-style-type: none"> 1. It is highly recommended to use a separate PSU and 0V return. (The I/O is internally isolated from the main 24V supply input.) 	
ADC / DAC	<ol style="list-style-type: none"> 1. Use DAC 0V reference pin not common 0V 	0V on Aux connector.
RS232 / RS422 / RS485	<ol style="list-style-type: none"> 1. Screened cable. 	Connect screen to Aux

Serial ports	<ol style="list-style-type: none"> 2. Connect screen to Chassis at both ends. 3. 0V reference connected at both ends. 	<p>connector shell.</p> <p>0V on Aux connector, pins 4, 8 and 12 are common 0V.</p>
Ethernet	<ol style="list-style-type: none"> 1. TIA Cat5e, minimum. 2. Shielded cable. 3. Cable $\leq 30m$ in length. 	<p>Overall Foil Braided Shield with Unshielded Twisted Pairs.</p> <p>Compliant with Industrial SF/UTP.</p>
EMC Earth Connection	<ol style="list-style-type: none"> 1. Mount on bare metal backplane. 2. Use a minimum 10mm wide, braided conductor to connect backplane / chassis to PE. 3. Do not use circular cross-section wire. 	<p>When the MC404-Z is screwed directly to the panel, the metal chassis provides the required EMC earth connection.</p>

Recommended Installation

The following diagrams and information detail the typically required Surge Protection, EMC Earth and Cable Shields however more comprehensive information can be found in the corresponding Product Technical Manual (available at www.triomotion.com)

Surge Protection

Single power supply

Where the device is supplied with 24V dc from one dedicated 24V power source and the connecting cable is less than 3 metres, there is no need for a separate surge protection device.

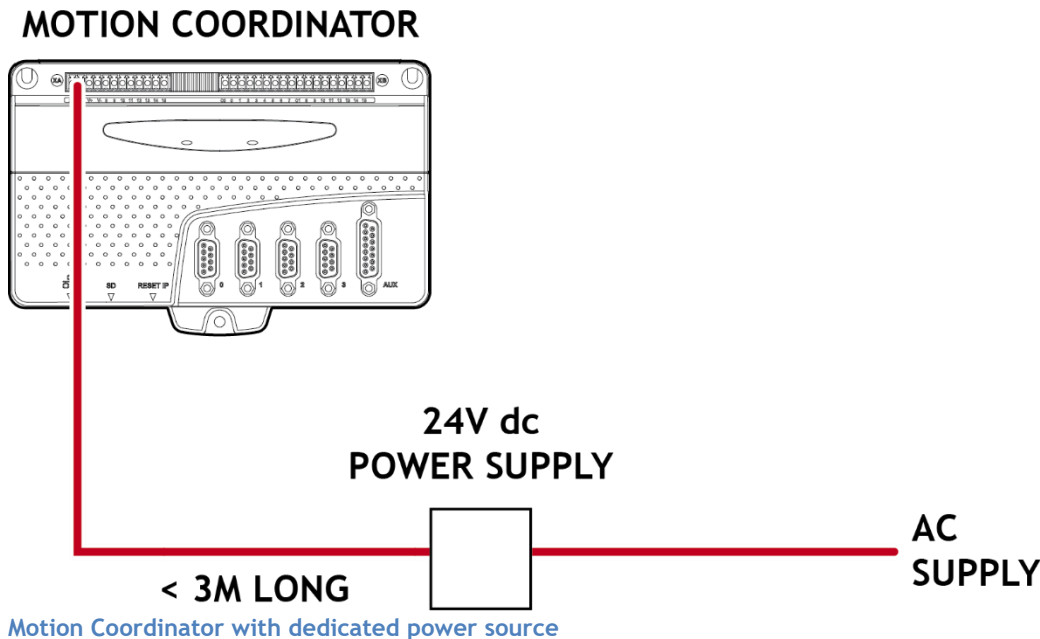

Distributed power supply

If the device is connected to a distributed power supply or the cable length between the power source and the device is longer than 3 metres, then a surge protection device must be fitted to comply with the CE EMC directive.

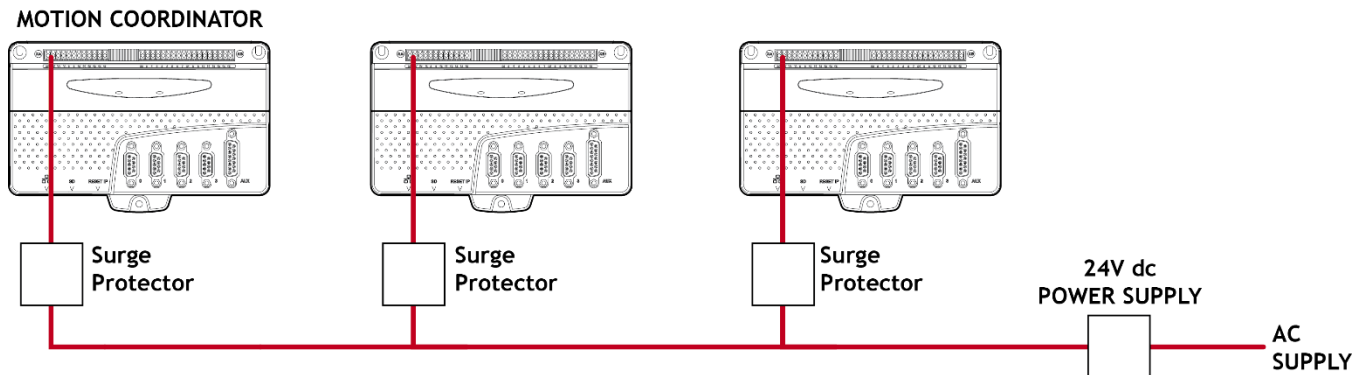

Distributed power supply with surge protection

Surge protection device

Protection device - Minimum specification	
Operating Voltage	24V dc
Suppression Begins:	
Stage Two	30V
Stage Three	35V
Max. Clamp Volts for transients on the line:	
Stage Two	65V
Stage Three	77V
Surge Current (8/20mSec Pulse)	
+ to -	9000A
+ to Earth	4000A
- to Earth	4000A
Surge Energy (2mSec Pulse)	
+ to -	94 Joules
+ to Earth	44 Joules
- to Earth	44 Joules
Response Time	<5 nsec
Resistance to Earth:	
Max Over-Voltage	0.01 Ω
Operating Voltage	> 1 M Ω

Cable Shields

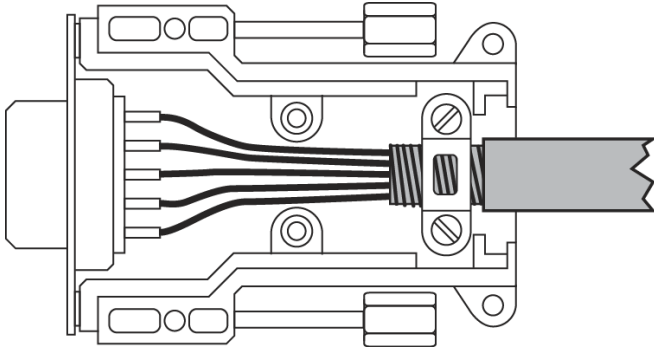

Both ends of the encoder cable's screen must be connected using a 360 degree contact and not a pig-tail connection.

The 0V must be connected separately from the screen. Make sure that encoder cables are specified with one extra wire to carry the 0V.

All serial cables must be terminated in the 15-pin auxiliary connector. For best EMC performance, clamp the screen of the serial cable where it enters the connector cover.

Do not make a "pig-tail" connection from the screen to the plug cover. The 0V must be connected separately from the screen.

Make sure that serial cables are specified with one extra wire to carry the 0V.

This applies to RS422/RS485 serial connections as well as RS232.