



**2**

<b>1</b>	<b>Important Information .....</b>	<b>2</b>
1.1	Instructions on Documentation .....	2
1.2	Safekeeping of the Documentation.....	2
1.3	Used Symbols .....	2
1.4	Qualified Staff .....	2
1.5	General Safety Instructions .....	3
<b>2</b>	<b>Overview of Screw Jacks.....</b>	<b>4</b>
<b>3</b>	<b>Design of the Screw Jack C-Series Type N .....</b>	<b>5</b>
<b>4</b>	<b>Design of Screw Jack C-Series Type R .....</b>	<b>6</b>
<b>5</b>	<b>Assembly.....</b>	<b>7</b>
5.1	General Assembly Instructions.....	7
5.2	Mounting Several Worm Gear Screw Jacks in Parallel .....	8
5.3	Screw Jacks with safety nut (optional with limit switch) .....	9
<b>6</b>	<b>Commissioning.....</b>	<b>10</b>
<b>7</b>	<b>Wartung.....</b>	<b>10</b>
7.1	Lubricants and Fill Quantities.....	11
<b>8</b>	<b>Malfunctions .....</b>	<b>12</b>
<b>9</b>	<b>Manufacturer's Declaration .....</b>	<b>13</b>

# 1 Important Information

This chapter contains important information on the safe handling of the product and on this operating manual.

## 1.1 Instructions on Documentation

The following instructions will guide you through the entire documentation.  
We assume no liability for damages resulting from non-compliance with this operating manual.  
Forward this operating manual to the plant operator so that it is available if needed.

## 1.2 Safekeeping of the Documentation

**Keep this operating manual and all other applicable documents safe so that they are available if needed.**

## 1.3 Used Symbols



Information

Instructions and information on the operation of the Screw Jacks.



Attention!

Non-compliance may result in material damage and impair the operation of the gear unit.



Warning!

Safety instruction: non-compliance may result in serious or fatal injuries.



QR Barcode

Provides a direct link to the products on our website. Compatible with QR barcode scanner apps for all Android, Apple and Windows smart phones / tablets.

## 1.4 Qualified Staff



Qualified staff according to this operating manual refers to specialists who are familiar with the installation, assembly, commissioning and operation of the worm gear screw jacks and the hazards involved and who possess the necessary capabilities on the basis of their specialist training and knowledge of the applicable standards.

### 1.5 General Safety Instructions

The following warnings, preventive measures and instructions are intended to guarantee your safety and to avoid damage to the lifting gear or the components connected to it. This chapter contains warnings and instructions that generally apply to the handling of the lifting gear.



#### Intended Use:

The Screw jacks C-Series are intended only to carry out lifting, lowering, tilting and feeding motions.

Please find lifting capacities in our catalog or at [www.neff-gewindetriebe.de](http://www.neff-gewindetriebe.de).

Any other use is considered misuse. The manufacturer assumes no liability for any damage resulting from misuse.

**If the device is installed in machines or plants, commissioning is prohibited until it is determined that it complies with the EC machinery directive.**

---



#### Attention!

**Requirement according to the German accident prevention regulations VBG14 / VBG 70:**

If worm gear screw jacks are operated in theatre stages (VBG 70), lifting platforms (VBG 14) or lifting equipment where there is a danger to persons, we generally recommend using a safety nut for fall protection.

---



#### Attention!

This operating manual must be kept close to the device and be easily accessible and available to all users.

---



#### Attention!

**Risk of damage to the lifting gear resulting from storage and transport.**

Correct storage, installation and assembly as well as diligent operation and maintenance are prerequisites for the trouble-free and safe operation of the worm gear screw jacks.

The worm gear screw jack must be protected against mechanical impacts and vibrations during transport and storage.

---



#### Warning!

**Work on live components:**

E.g. installation of limit switches or a drive unit must only be carried out by trained electricians.

---

## 2 Overview of Screw Jacks



### Description of a Screw Jacks:

Neff Screw Jacks C-Series are used for applications where precise lifting, lowering, tilting and feeding motions are required. The classic gear housing allows the mounting of a motor, gearbox or encoder. All models are designed to cater for pressure and tensile loads as well as position-independent operation.

Basically, 2 different movement principles have to be distinguished:

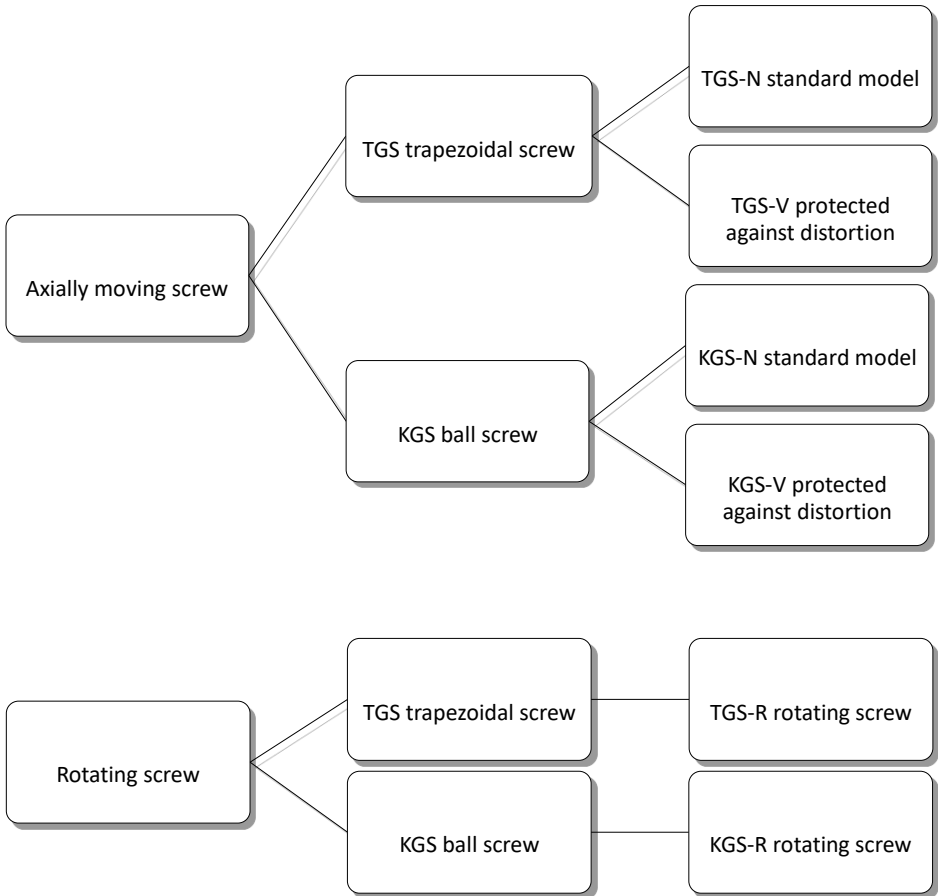

### 3 Design of the Screw Jack C-Series Type N

Version C-Series with trapezoidal threaded screw type N (axial moving spindle, not secured against torsion)

Position	Designation
1	Housing
2	Intermediate flange
3	Bearing cover
4	Worm gear
5	Worm gear shaft
6	Cover tube
7	Trapezoidal screw
8	Axial grooved ball bearing
9	Bevel bearing
10	O-ring
11	Radial-shaft seal ring DIN 3760
12	Snap ring DIN 471
13	Radial-shaft seal ring DIN 3760
14	Fitted key DIN 6885
15	Grub screw
16	Shim ring
17	O-ring
18	Bolt
19	Cover tube end cap

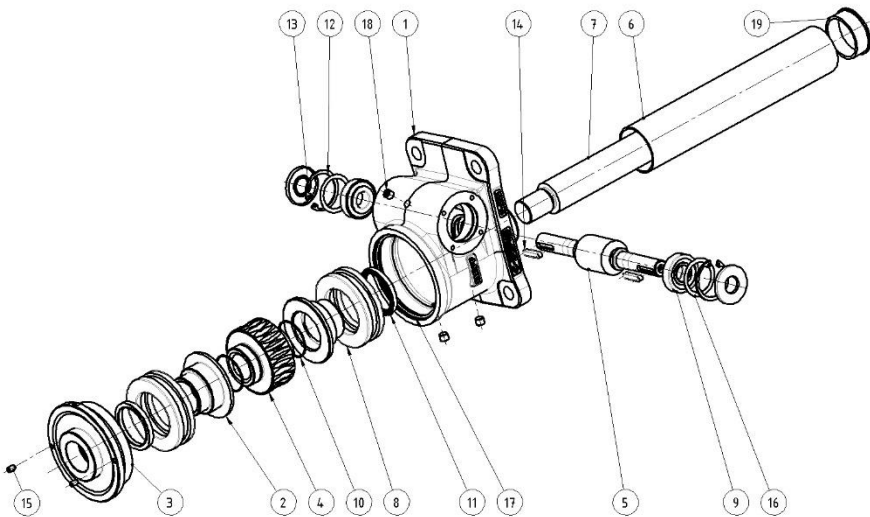

## 4 Design of Screw Jack C-Series Type R

Version SHG C-Series with trapezoidal threaded spindle type R (rotating screw)

Position	Designation
1	Housing
2	R-bush
3	Bearing cover
4	Worm gear
5	Worm gear shaft
6	Trapezoidal screw
7	Axial grooved ball bearing
8	Bevel bearing
9	Snap ring DIN 471
10	Radial-shaft seal ring DIN 3760
11	Fitted key DIN 6885
12	Grub screw
13	KMT nut
14	Grooved ball bearing or taper roller bearing
15	Radial-shaft seal ring DIN 3760
16	Snap ring DIN 471
17	Fitted key DIN 6885
18	Shim ring DIN 988
19	O-ring DIN 3601
20	Bolt
21	O-ring DIN 3601
22	End cap
23	Trapezoidal nut

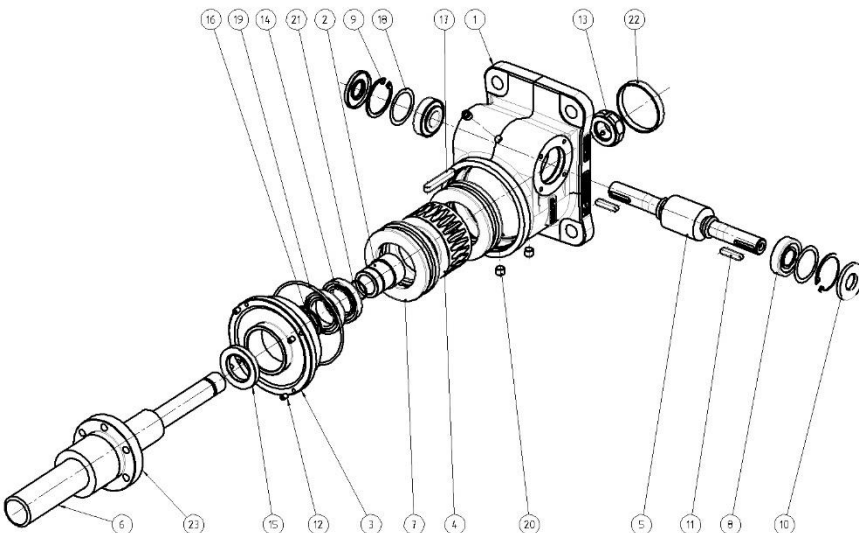

## 5 Assembly

### 5.1 General Assembly Instructions



The worm gear screw jack is fastened via the housing or other fastening components (mounting plates or cardan adapters, see QR code below). The housing always needs to be screwed to a machined surface (not to rolled steel profiles or similar) in order to avoid misalignment or noise.

Depending on the respective application, the worm gear screw jack and the screw have to be precisely aligned at a right angle or in parallel to the machine component and tightened during assembly.

The tolerances of the four assembly sides correspond to the DIN ISO 2768-mH standard.

Size	C3	C5	C15	C20
<b>Bolts (min. 8.8)</b>	M12	M16	M20	M27
<b>Length of engagement</b>	16	24	30	40
<b>Max. torque in Nm</b>	89	215	420	1070

The torques mentioned in the table are only rough and nonbinding guidelines – see VDI 2230.



Lateral forces have to be absorbed by suitable guiderails; otherwise the device lifecycle would be shortened.



#### Attention!

The lubrication nipples must always be accessible during operation.



#### Attention!

Do not hammer the shaft end or the screw when aligning the worm gear screw jack.

QR barcode to Neff fastenings:



QR barcode to Neff attachments:





## 5.2 Mounting Several Worm Gear Screw Jacks in Parallel

**Requirement:**

One worm gear screw jack is already installed and fastened as described in chapter 4.



1. Bring the second worm gear screw jack into the planned position, but do not fasten it yet.
  2. If rotating screws are used, bring the travelling nuts into the same position.
  3. Push the coupling or drive shaft onto the worm gear shaft of the worm gear screw jack that is already fastened.
  4. Push the coupling or drive shaft onto the worm gear shaft of the second worm gear screw jack.
  5. Fasten the worm gear screw jack.
  6. Repeat steps 1-5 with any other gear units.
- 

**Attention!**

Check the sense of rotation of all lifting elements before assembly.

---

**Attention!**

Use torsionally flexible couplings, drive shafts or cardan shafts in order to compensate for any misalignment of the worm gear screw jackets.

---

**Attention!**

Observe the lubricating film and screw temperature during run-in. If the screw quickly runs dry (or if there are loud running noises with ball screws) and if the temperature is increased despite observing duty time and permissible power, this indicates impermissible lateral forces.

---

QR barcode to Neff couplings:



QR barcode to Neff drive shafts:



### 5.3 Screw Jacks with safety nut (optional with limit switch)

**Safety nut acc. to VBG14 or VBG70 requirements only will available on request. If nothing else is specified, our standard safety catch nuts will be delivered. In this connection, the technical data of the safety catch nut always shall be counter-checked against the existing requirements.**

#### **i** Standard safety nut with trapezoidal or slide thread:

The safety nut will rotate without axial load and thus without any wear with the running nut. At increased wear (trapezoidal or slide thread design), the distance X between both nuts will decrease. At a reduction of 25% of the distance X, the running nut shall be replaced.

For this purpose, the measure X shall be recorded during commissioning and periodically be checked by a maintenance plan.

In case of rupture of the thread turns of the running nut due to increased wear or excessive load, the safety nut will pick up the supported load.

Technical data:

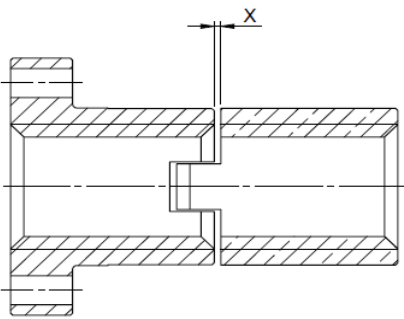
Thread designation:	measure X:	
Trapezoidal thread: Tr12 x X – Tr50 x X:	4mm	
Trapezoidal thread Tr>50 x X:	8mm	
Ball thread:	distance X = ball size Dw	
Trapezoidal thread DIN 380 FTTr32-180 x X:	2,5mm	

#### **i** Standard safety nut with ball thread:

Safety nuts for ball thread nuts always will be manufactured individually in accordance with the intended use and the ball size.

Normally the ball thread unit will get locked in case of failure and call for attention by an excessive power input.

The safety distance X always will be defined in accordance with the size of the ball.

An optical wear control only will be possible at ball rupture or complete destruction of the deflection pieces.

For this reason, we recommend the integration of a torque supervision in the motor control.

The safety nuts will be dimensioned in accordance with the maximum static load of the ball thread nut and will pick up the load at failure of the nut.

## 6 Commissioning



### Attention!

Screw Jack oil filled and with vent valve: Install enclosed vent valve before operation.  
Note install position, vent valve must be mounted above the oil level.



### Attention!

Check the operation of the limit switch. If possible, start the worm gear screw jack without any load and increase the load slowly.

During commissioning, continuously check the operating temperature, power consumption of the motor and the screw contact pattern.

## 7 Wartung



- **With trapezoidal screws, regularly** lubricate the screw.
- **Bei Version VK** The anti rotating block must be regularly lubricated. Move the Screw Jack to the start position and lubricate over the grease nipple. Prevent dry running! Recommendation for the interval: check once a month and if necessary relubricate (depending on application)
- **With ball screws (R-Version), observe the following guideline:** lubricate approx. every 200 hours with 1ml per 10mm of screw diameter. For N-Version: Ball screw with lifetime lubrication
- **Approx. 5 operating hours** after commissioning: Retighten all attachment bolts.
- **After approx. 200 operating hours or 1 year** (sooner in tough operating conditions): Check the screw nut for signs of wear and tear.  
Clean the screw of old grease and relubricate.
- **NEFF Screw Jacks lifetime-lubricated** if thermal and mechanical limits are met.
- **Demontage des Lagerdeckels:**
- **Disassembly bearing cover:**
  1. Remove the grub screws at the bearing cover
  2. Take the screw out (remove screw protection if required).
  3. Unscrew the bearing cover.
  4. Remove the old grease.
  5. Refill with new grease.
  6. Strongly press the bearing cover down (10 times the normal contact force).
  7. Loosen the bearing cover again.
  8. Put the bearing cover into place and fasten the grub screws.



### Attention!

When assembling the bearing cover, make sure it fits smoothly and that there is no axial play.



### Attention!

Change the screw nut if the axial play exceeds 1/4 of the thread pitch (trapezoidal thread).

## 7.1 Lubricants and Fill Quantities



Types of factory grease:

Screw Jack / Trapezoidal screw:

NEFF GREASE 000 / NEFF GREASE 2

Safety data sheet NEFF GREASE 000 / 2:



Ball screw:

NEFF GREASE 2/3

Safety data sheet NEFF GREASE 2/3:



Fill quantities:

Type	C3	C5	C15	C20
Fill quantities grease in gr.	400	500	800	900
Fill quantities oil in gr.	400	500	800	900



In addition to our factory lubricants, other equivalent brand lubricants may also be used. This only applies if they are compared to the data sheets of the above manufacturers.



To much grease increases friction and therefore causes an increase in temperature. There is a sufficient amount of lubricant when a small amount of grease begins to exit at the sealing lips.

## 8 Malfunctions



**Service:** Should malfunctions occur during operation, first try to identify the manner of the malfunction with the table below and to repair it. If it is a malfunction you can't repair, please contact our technical service (see last page).

Malfunction	Cause	Remedy
Unusual, constant running noises.	<ul style="list-style-type: none"> <li>➤ Rolling / grinding: Bearing damage</li> <li>➤ Tapping: Irregularity in gearing</li> </ul>	Check grease fill level. Consult the technical service.
Unusual, irregular running noises.	Foreign object in the grease.	Check grease fill level. Stop drive. Consult the technical service.
Unusually high temperature at the housing.	<ul style="list-style-type: none"> <li>➤ Not enough grease.</li> <li>➤ Defective gearing or bearing.</li> </ul>	Check and correct grease filling. Consult the technical service.
Grease or oil exists at the shaft seal ring.	Defective sealing.	Consult the technical service.
Grease or oil exists at the shaft seal ring and at the screw.	Too much grease in the gear.	Check and correct grease fill level. Consult the technical service.
Trapezoidal screw quickly runs dry.	Assembly fault: Impermissible lateral forces.	Repair assembly fault. Consult the technical service.
The worm gear shaft does not turn or the screw turns but does not move although the worm gear shaft is turned.	The connection between the shaft and the hub or the gearing is broken.	Have the gear repaired.

## 9 Manufacturer's Declaration

**We hereby declare that the following product:**

Screw Jack, version M-J / MH-JH  
with trapezoidal screws or ball screws  
model N, R or V  
in the sizes  
C3, C5, C15, C20  
for lifting and lowering loads

was manufactured in accordance with the EC machinery directive 2006/42/EC annex II B on incomplete machinery.

This incomplete machinery must not be commissioned until the machine it is to be incorporated in has been declared to comply with the provisions of the EC machinery directive, the harmonized standards, European standards or the applicable national standards.

The manufacturer undertakes to forward the documentation on the incomplete machinery to national authorities on request. The technical documentation was created according to annex VII B.

**Person responsible for documentation:**

Andreas Ries, Director of quality management

**Address of the person responsible for documentation:**

Neff Gewindetriebe GmbH  
Karl-Benz-Str. 24  
71093 Weil im Schönbuch  
Germany

**The following harmonized standards have been applied:**

**DIN EN ISO 12100-1** Safety of machinery – Basic concepts, general principles for design, part 1: Basic terminology, methodology

**DIN EN ISO 12100-2** Safety of machinery – Basic concepts, general principles for design, part 2: Technical principles and specifications

**The following national standards, guidelines and specifications have been applied:**

**BGV D8** Accident prevention regulations for hoist gears, lifting and towing equipment

Neff Gewindetriebe GmbH  
Karl-Benz-Str. 24  
71093 Weil im Schönbuch  
+49(0)7157/53890-0

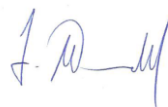

Notice:

Notice:



Notice: