

IF Actuator (IS Belt-Driven Type) Operating Manual

===== Twelfth Edition =====

Small Belt Type	IF-SA-60, IF-SA-100
Medium Belt Type	IF-MA-200, IF-MA-400

Before Use

Thank you for purchasing our product.

This Operation Manual describes all necessary information to operate this product safely such as the operation procedure, structure and maintenance procedure.

Before operation, read this manual carefully and fully understand it to operate this product safely. The DVD that comes with the product contains instruction manuals for IAI products. For a use of the products, print out or display on your personal computer the necessary pages of the applicable Operation Manuals.

After reading the Operation Manuals, be sure to keep them in a convenient place easily accessible to the personnel using this product.

[Important]

- This Operation Manual is original.
- IAI shall not be liable whatsoever for any loss or damage arising from the result of using the product for any other purpose from what is noted in the manual.
- The information contained in this Operation Manual is subject to change without notice for the purpose of production improvement.
- If you have any question or finding regarding the information contained in this Operation Manual, contact our customer center or our sales office near you.
- Using or copying all or a part of this Operation Manual without permission is prohibited.
- The company names, names of products and trademarks of our company shown in the sentences are registered trademarks.



INTELLIGENT ACTUATOR

CE Marking

If a compliance with the CE Marking is required, please follow Overseas Standards Compliance Manual (ME0287) that is provided separately.

Table of Contents

Safety Guide	1
Caution in Handling	8
Names of the Parts	9
1. Specifications Check	11
1.1 Product Check	11
1.1.1 Parts	11
1.1.2 Operation Manuals related to this product, which are contained in the DVD.	12
1.1.3 How to read the model plate	13
1.1.4 How to read the model No.	14
1.2 Specification	15
1.3 Option	17
1.3.1 AQ Seal	17
1.3.2 Creep Sensor	17
1.3.3 Home Limit Switch	17
1.3.4 Reversed-home Type	17
1.3.5 Guide with Ball Retainer Mechanism	17
1.3.6 W Slider	17
1.3.7 Metal Connector Type	17
1.4 Motor • Encoder Cables	18
1.4.1 Standard	18
1.4.2 CE Type (Option Model code : EU)	23
2. Installation	26
2.1 Transportation	26
2.2 Installation and Storage Environment	28
2.3 How to Install	29
2.3.1 Orientation of the Actuator Installation	29
2.3.2 Installation	30
3. Connection to the controller	35
4. Setting the Home Position	40
5. Maintenance inspection	41
5.1 Inspection Items and Inspection Schedule	41
5.2 Visual inspection	41
5.3 Cleaning	41
5.4 Internal Inspection	42
5.5 Internal Cleanup	42
5.6 Grease Supply	43
5.7 How to Inspect the Timing Belt	44
5.7.1 Belt Tension Adjustment Method	45
5.8 How to Replace the Timing Belt	47
5.9 Deceleration Belt Replacement	54
5.10 Motor Replacement Process	57



6.	External Dimensions	61
6.1	IF-SA-60	61
6.2	IF-SA-100	62
6.3	IF-MA-200	63
6.4	IF-MA-400	64
7.	Life	65
8.	Warranty	66
8.1	Warranty Period	66
8.2	Scope of the Warranty	66
8.3	Honoring the Warranty	66
8.4	Limit in Responsibility	67
8.5	Conditions of Conformance with Applicable Standards/Regulations, Etc., and Applications	67
8.6	Other Items Excluded from Warranty	67
	Change History	68

Safety Guide

“Safety Guide” has been written to use the machine safely and so prevent personal injury or property damage beforehand. Make sure to read it before the operation of this product.

Safety Precautions for Our Products

The common safety precautions for the use of any of our robots in each operation.

No.	Operation Description	Description
1	Model Selection	<ul style="list-style-type: none"> ● This product has not been planned and designed for the application where high level of safety is required, so the guarantee of the protection of human life is impossible. Accordingly, do not use it in any of the following applications. <ol style="list-style-type: none"> 1) Medical equipment used to maintain, control or otherwise affect human life or physical health. 2) Mechanisms and machinery designed for the purpose of moving or transporting people (For vehicle, railway facility or air navigation facility) 3) Important safety parts of machinery (Safety device, etc.) ● Do not use the product outside the specifications. Failure to do so may considerably shorten the life of the product. ● Do not use it in any of the following environments. <ol style="list-style-type: none"> 1) Location where there is any inflammable gas, inflammable object or explosive 2) Place with potential exposure to radiation 3) Location with the ambient temperature or relative humidity exceeding the specification range 4) Location where radiant heat is added from direct sunlight or other large heat source 5) Location where condensation occurs due to abrupt temperature changes 6) Location where there is any corrosive gas (sulfuric acid or hydrochloric acid) 7) Location exposed to significant amount of dust, salt or iron powder 8) Location subject to direct vibration or impact ● For an actuator used in vertical orientation, select a model which is equipped with a brake. If selecting a model with no brake, the moving part may drop when the power is turned OFF and may cause an accident such as an injury or damage on the work piece.

No.	Operation Description	Description
2	Transportation	<ul style="list-style-type: none"> ● When carrying a heavy object, do the work with two or more persons or utilize equipment such as crane. ● When the work is carried out with 2 or more persons, make it clear who is to be the leader and who to be the follower(s) and communicate well with each other to ensure the safety of the workers. ● When in transportation, consider well about the positions to hold, weight and weight balance and pay special attention to the carried object so it would not get hit or dropped. ● Transport it using an appropriate transportation measure. The actuators available for transportation with a crane have eyebolts attached or there are tapped holes to attach bolts. Follow the instructions in the operation manual for each model. ● Do not step or sit on the package. ● Do not put any heavy thing that can deform the package, on it. ● When using a crane capable of 1t or more of weight, have an operator who has qualifications for crane operation and sling work. ● When using a crane or equivalent equipments, make sure not to hang a load that weighs more than the equipment's capability limit. ● Use a hook that is suitable for the load. Consider the safety factor of the hook in such factors as shear strength. ● Do not get on the load that is hung on a crane. ● Do not leave a load hung up with a crane. ● Do not stand under the load that is hung up with a crane.
3	Storage and Preservation	<ul style="list-style-type: none"> ● The storage and preservation environment conforms to the installation environment. However, especially give consideration to the prevention of condensation. ● Store the products with a consideration not to fall them over or drop due to an act of God such as earthquake.
4	Installation and Start	<p>(1) Installation of Robot Main Body and Controller, etc.</p> <ul style="list-style-type: none"> ● Make sure to securely hold and fix the product (including the work part). A fall, drop or abnormal motion of the product may cause a damage or injury. Also, be equipped for a fall-over or drop due to an act of God such as earthquake. ● Do not get on or put anything on the product. Failure to do so may cause an accidental fall, injury or damage to the product due to a drop of anything, malfunction of the product, performance degradation, or shortening of its life. ● When using the product in any of the places specified below, provide a sufficient shield. <ol style="list-style-type: none"> 1) Location where electric noise is generated 2) Location where high electrical or magnetic field is present 3) Location with the mains or power lines passing nearby 4) Location where the product may come in contact with water, oil or chemical droplets

No.	Operation Description	Description
4	Installation and Start	<p>(2) Cable Wiring</p> <ul style="list-style-type: none"> ● Use our company's genuine cables for connecting between the actuator and controller, and for the teaching tool. ● Do not scratch on the cable. Do not bend it forcibly. Do not pull it. Do not coil it around. Do not insert it. Do not put any heavy thing on it. Failure to do so may cause a fire, electric shock or malfunction due to leakage or continuity error. ● Perform the wiring for the product, after turning OFF the power to the unit, so that there is no wiring error. ● When the direct current power (+24V) is connected, take the great care of the directions of positive and negative poles. If the connection direction is not correct, it might cause a fire, product breakdown or malfunction. ● Connect the cable connector securely so that there is no disconnection or looseness. Failure to do so may cause a fire, electric shock or malfunction of the product. ● Never cut and/or reconnect the cables supplied with the product for the purpose of extending or shortening the cable length. Failure to do so may cause the product to malfunction or cause fire. <p>(3) Grounding</p> <ul style="list-style-type: none"> ● The grounding operation should be performed to prevent an electric shock or electrostatic charge, enhance the noise-resistance ability and control the unnecessary electromagnetic radiation. ● For the ground terminal on the AC power cable of the controller and the grounding plate in the control panel, make sure to use a twisted pair cable with wire thickness 0.5mm² (AWG20 or equivalent) or more for grounding work. For security grounding, it is necessary to select an appropriate wire thickness suitable for the load. Perform wiring that satisfies the specifications (electrical equipment technical standards). ● Perform Class D Grounding (former Class 3 Grounding with ground resistance 100Ω or below).





No.	Operation Description	Description
4	Installation and Start	<p>(4) Safety Measures</p> <ul style="list-style-type: none"> ● When the work is carried out with 2 or more persons, make it clear who is to be the leader and who to be the follower(s) and communicate well with each other to ensure the safety of the workers. ● When the product is under operation or in the ready mode, take the safety measures (such as the installation of safety and protection fence) so that nobody can enter the area within the robot's movable range. When the robot under operation is touched, it may result in death or serious injury. ● Make sure to install the emergency stop circuit so that the unit can be stopped immediately in an emergency during the unit operation. ● Take the safety measure not to start up the unit only with the power turning ON. Failure to do so may start up the machine suddenly and cause an injury or damage to the product. ● Take the safety measure not to start up the machine only with the emergency stop cancellation or recovery after the power failure. Failure to do so may result in an electric shock or injury due to unexpected power input. ● When the installation or adjustment operation is to be performed, give clear warnings such as "Under Operation; Do not turn ON the power!" etc. Sudden power input may cause an electric shock or injury. ● Take the measure so that the work part is not dropped in power failure or emergency stop. ● Wear protection gloves, goggle or safety shoes, as necessary, to secure safety. ● Do not insert a finger or object in the openings in the product. Failure to do so may cause an injury, electric shock, damage to the product or fire. ● When releasing the brake on a vertically oriented actuator, exercise precaution not to pinch your hand or damage the work parts with the actuator dropped by gravity.
5	Teaching	<ul style="list-style-type: none"> ● When the work is carried out with 2 or more persons, make it clear who is to be the leader and who to be the follower(s) and communicate well with each other to ensure the safety of the workers. ● Perform the teaching operation from outside the safety protection fence, if possible. In the case that the operation is to be performed unavoidably inside the safety protection fence, prepare the "Stipulations for the Operation" and make sure that all the workers acknowledge and understand them well. ● When the operation is to be performed inside the safety protection fence, the worker should have an emergency stop switch at hand with him so that the unit can be stopped any time in an emergency. ● When the operation is to be performed inside the safety protection fence, in addition to the workers, arrange a watchman so that the machine can be stopped any time in an emergency. Also, keep watch on the operation so that any third person can not operate the switches carelessly. ● Place a sign "Under Operation" at the position easy to see. ● When releasing the brake on a vertically oriented actuator, exercise precaution not to pinch your hand or damage the work parts with the actuator dropped by gravity. <p>* Safety protection Fence : In the case that there is no safety protection fence, the movable range should be indicated.</p>

No.	Operation Description	Description
6	Trial Operation	<ul style="list-style-type: none"> ● When the work is carried out with 2 or more persons, make it clear who is to be the leader and who to be the follower(s) and communicate well with each other to ensure the safety of the workers. ● After the teaching or programming operation, perform the check operation one step by one step and then shift to the automatic operation. ● When the check operation is to be performed inside the safety protection fence, perform the check operation using the previously specified work procedure like the teaching operation. ● Make sure to perform the programmed operation check at the safety speed. Failure to do so may result in an accident due to unexpected motion caused by a program error, etc. ● Do not touch the terminal block or any of the various setting switches in the power ON mode. Failure to do so may result in an electric shock or malfunction.
7	Automatic Operation	<ul style="list-style-type: none"> ● Check before starting the automatic operation or rebooting after operation stop that there is nobody in the safety protection fence. ● Before starting automatic operation, make sure that all peripheral equipment is in an automatic-operation-ready state and there is no alarm indication. ● Make sure to operate automatic operation start from outside of the safety protection fence. ● In the case that there is any abnormal heating, smoke, offensive smell, or abnormal noise in the product, immediately stop the machine and turn OFF the power switch. Failure to do so may result in a fire or damage to the product. ● When a power failure occurs, turn OFF the power switch. Failure to do so may cause an injury or damage to the product, due to a sudden motion of the product in the recovery operation from the power failure.

No.	Operation Description	Description
8	Maintenance and Inspection	<ul style="list-style-type: none"> ● When the work is carried out with 2 or more persons, make it clear who is to be the leader and who to be the follower(s) and communicate well with each other to ensure the safety of the workers. ● Perform the work out of the safety protection fence, if possible. In the case that the operation is to be performed unavoidably inside the safety protection fence, prepare the “Stipulations for the Operation” and make sure that all the workers acknowledge and understand them well. ● When the work is to be performed inside the safety protection fence, basically turn OFF the power switch. ● When the operation is to be performed inside the safety protection fence, the worker should have an emergency stop switch at hand with him so that the unit can be stopped any time in an emergency. ● When the operation is to be performed inside the safety protection fence, in addition to the workers, arrange a watchman so that the machine can be stopped any time in an emergency. Also, keep watch on the operation so that any third person can not operate the switches carelessly. ● Place a sign “Under Operation” at the position easy to see. ● For the grease for the guide or ball screw, use appropriate grease according to the Operation Manual for each model. ● Do not perform the dielectric strength test. Failure to do so may result in a damage to the product. ● When releasing the brake on a vertically oriented actuator, exercise precaution not to pinch your hand or damage the work parts with the actuator dropped by gravity. ● The slider or rod may get misaligned OFF the stop position if the servo is turned OFF. Be careful not to get injured or damaged due to an unnecessary operation. ● Pay attention not to lose the cover or untightened screws, and make sure to put the product back to the original condition after maintenance and inspection works. Use in incomplete condition may cause damage to the product or an injury. <p>* Safety protection Fence : In the case that there is no safety protection fence, the movable range should be indicated.</p>
9	Modification and Dismantle	<ul style="list-style-type: none"> ● Do not modify, disassemble, assemble or use of maintenance parts not specified based at your own discretion.
10	Disposal	<ul style="list-style-type: none"> ● When the product becomes no longer usable or necessary, dispose of it properly as an industrial waste. ● When removing the actuator for disposal, pay attention to drop of components when detaching screws. ● Do not put the product in a fire when disposing of it. The product may burst or generate toxic gases.
11	Other	<ul style="list-style-type: none"> ● Do not come close to the product or the harnesses if you are a person who requires a support of medical devices such as a pacemaker. Doing so may affect the performance of your medical device. ● See Overseas Specifications Compliance Manual to check whether complies if necessary. ● For the handling of actuators and controllers, follow the dedicated operation manual of each unit to ensure the safety.

Alert Indication

The safety precautions are divided into “Danger”, “Warning”, “Caution” and “Notice” according to the warning level, as follows, and described in the Operation Manual for each model.

Level	Degree of Danger and Damage	Symbol
Danger	This indicates an imminently hazardous situation which, if the product is not handled correctly, will result in death or serious injury.	 Danger
Warning	This indicates a potentially hazardous situation which, if the product is not handled correctly, could result in death or serious injury.	 Warning
Caution	This indicates a potentially hazardous situation which, if the product is not handled correctly, may result in minor injury or property damage.	 Caution
Notice	This indicates lower possibility for the injury, but should be kept to use this product properly.	 Notice

Caution in Handling

- 1. Do not have the settings of speed and acceleration/deceleration exceeding the rated values.**

An operation with speed and acceleration/deceleration beyond the allowable range may cause an abnormal noise, vibration, malfunction or shortened life.

When having an interpolating operation for combined axes, set the smallest value among the combined axes for each of speed and acceleration/deceleration settings.
- 2. Set the allowable load moment within the allowable range.**

Use the product with the applied load moment within the allowable range.

An operation with the load beyond the allowable load moment may cause an abnormal noise, vibration, malfunction or shortened life. If it is extreme, flaking may occur on the guide.
- 3. Set the overhang length within the allowable range.**

Have the overhang length of the load within the allowable range. The overhang length above the allowable range may cause vibration or abnormal noise.
- 4. Back and forth operation in a short distance may cause wear of grease.**

Continuous back and forth operation within a distance less than 30mm may cause wear of grease.

As a reference, have approximately 5 cycles of back and forth operation in a distance more than 50mm in every 5,000 to 10,000 cycles to regenerate the oil film. Keep using the actuator with the grease worn out may cause malfunction. If it is extreme, flaking may occur on the guide.
- 5. Ensure use of the product in the specified conditions, environments and ranges.**

Operation out of the specified conditions could cause a drop in performance or malfunction of the product.

Names of the Parts

In this manual, the right and left sides of the actuator are expressed in the way it is placed horizontally as shown in the figure below, and is looked at from the motor side.

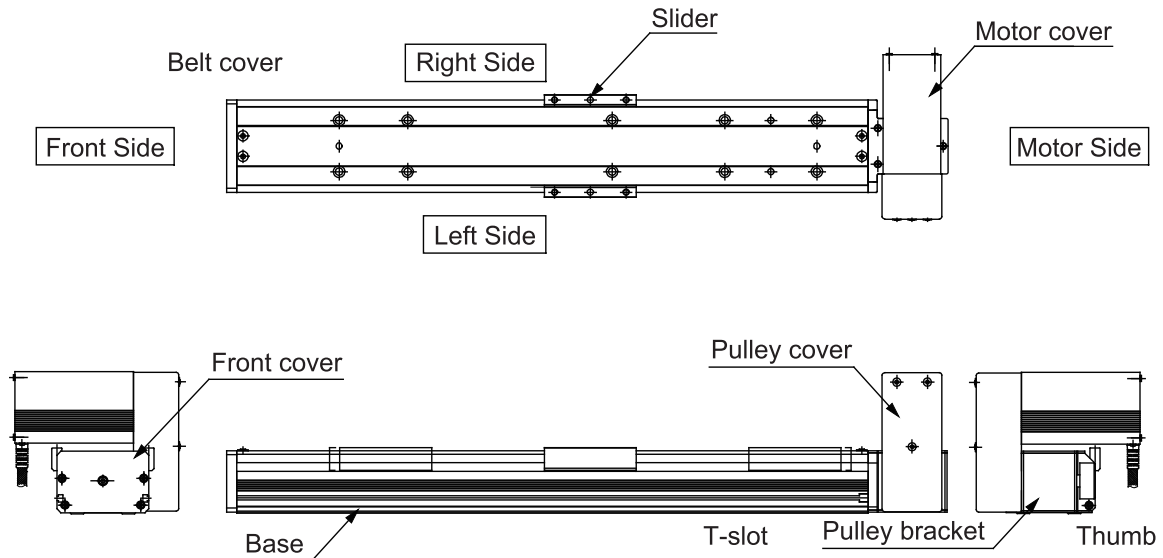

The motor location shown above is for the standard type.

1. Specifications Check

1.1 Product Check

The standard configuration of this product is comprised of the following parts. See the component list for the details of the enclosed components. If you find any broken or missing parts, contact your local IAI distributor.

1.1.1 Parts

No.	Part Name	Model	Quantity	Remarks
1	Main Body	Refer to "How to read the model plate", "How to read the model No."	1	
Accessories				
2	Motor • Encoder Cables ^(Note 1)		1 set	
3	In-House Made Seals		1 set	
4	First Step Guide		1	
5	Operating Manual (DVD)		1	
6	Safety Guide		1	

Note 1 The motor/encoder cables differ between the standard model and robot cable. [Refer to 1.4 Motor • Encoder Cables.]

1.1.2 Operation Manuals related to this product, which are contained in the DVD.

Shown below is a list of the operation manuals for the controllers related to this product which is recorded in Operation Manual (DVD).

(1) XSEL-J/K Controller

No.	Name	Manual No.
1	XSEL-J/K Controller Operation Manual	ME0116
2	PC Software IA-101-X-MW/IA-101-X-USBMW Operation Manual	ME0154
3	Touch Panel Teaching TB-01, TB-01D, TB01DR Applicable for Program Controller Operation Manual	ME0325
4	Teaching Pendant SEL-T/TD/TG Operation Manual	ME0183
5	Teaching Pendant IA-T-X/XD Operation Manual	ME0160
6	DeviceNet Operation Manual	ME0124
7	CC-Link Operation Manual	ME0123
8	PROFIBUS-DP Operation Manual	ME0153
9	XSEL Ethernet Operation Manual	ME0140
10	Multi-Point I/O Board Operation Manual	ME0138
11	Multi-Point I/O Board Dedicated Terminal Board Operation Manual	ME0139

(2) XSEL-P/Q, XSEL-R/S Controller

No.	Name	Manual No.
1	XSEL-P/Q Controller Operation Manual	ME0148
2	XSEL-R/S Controller Operation Manual	ME0313
3	XSEL-P/Q/PX/QX RC Gateway Function Operation Manual	ME0188
4	PC Software IA-101-X-MW/IA-101-X-USBMW Operation Manual	ME0154
5	Touch Panel Teaching TB-01, TB-01D, TB01DR Applicable for Program Controller Operation Manual	ME0325
6	Teaching Pendant SEL-T/TD/TG Operation Manual	ME0183
7	Teaching Pendant IA-T-X/XD Operation Manual	ME0160
8	DeviceNet Operation Manual	ME0124
9	CC-Link Operation Manual	ME0123
10	PROFIBUS-DP Operation Manual	ME0153

(3) SSEL Controller

No.	Name	Manual No.
1	SSEL Controller Operation Manual	ME0157
2	PC Software IA-101-X-MW/IA-101-X-USBMW Operation Manual	ME0154
3	Touch Panel Teaching TB-01, TB-01D, TB01DR Applicable for Program Controller Operation Manual	ME0325
4	Teaching Pendant SEL-T/TD/TG Operation Manual	ME0183
5	Teaching Pendant IA-T-X/XD Operation Manual	ME0160
6	DeviceNet Operation Manual	ME0124
7	CC-Link Operation Manual	ME0123
8	PROFIBUS-DP Operation Manual	ME0153

(4) SCON, MSCON Controller

No.	Name	Manual No.
1	SCON Controller Operation Manual	ME0161
2	SCON-CA Controller Operation Manual	ME0243
3	MSCON Controller Operation Manual	ME0306
4	PC Software RCM-101-MW/RCM-101-USB Operation Manual	ME0155
5	Touch Panel Teaching TB-01, TB-01D, TB01DR Applicable for Position Controllers Operation Manual	ME0324
6	Teaching Pendant CON-T/TG Operation Manual	ME0178
7	Touch Panel Teaching CON-PT/PD/PG Operation Manual	ME0227
8	Simplified Teaching Pendant RCM-E Operation Manual	ME0174
9	Data setter RCM-P Operation Manual	ME0175
10	Touch Panel Display RCM-PM-01 Operation Manual	ME0182
11	DeviceNet Operation Manual	ME0124
12	CC-Link Operation Manual	ME0123
13	PROFIBUS-DP Operation Manual	ME0153

1.1.3 How to read the model plate

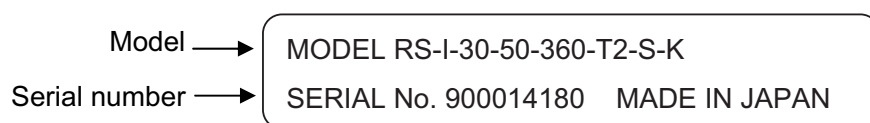

1.1.4 How to read the model No.

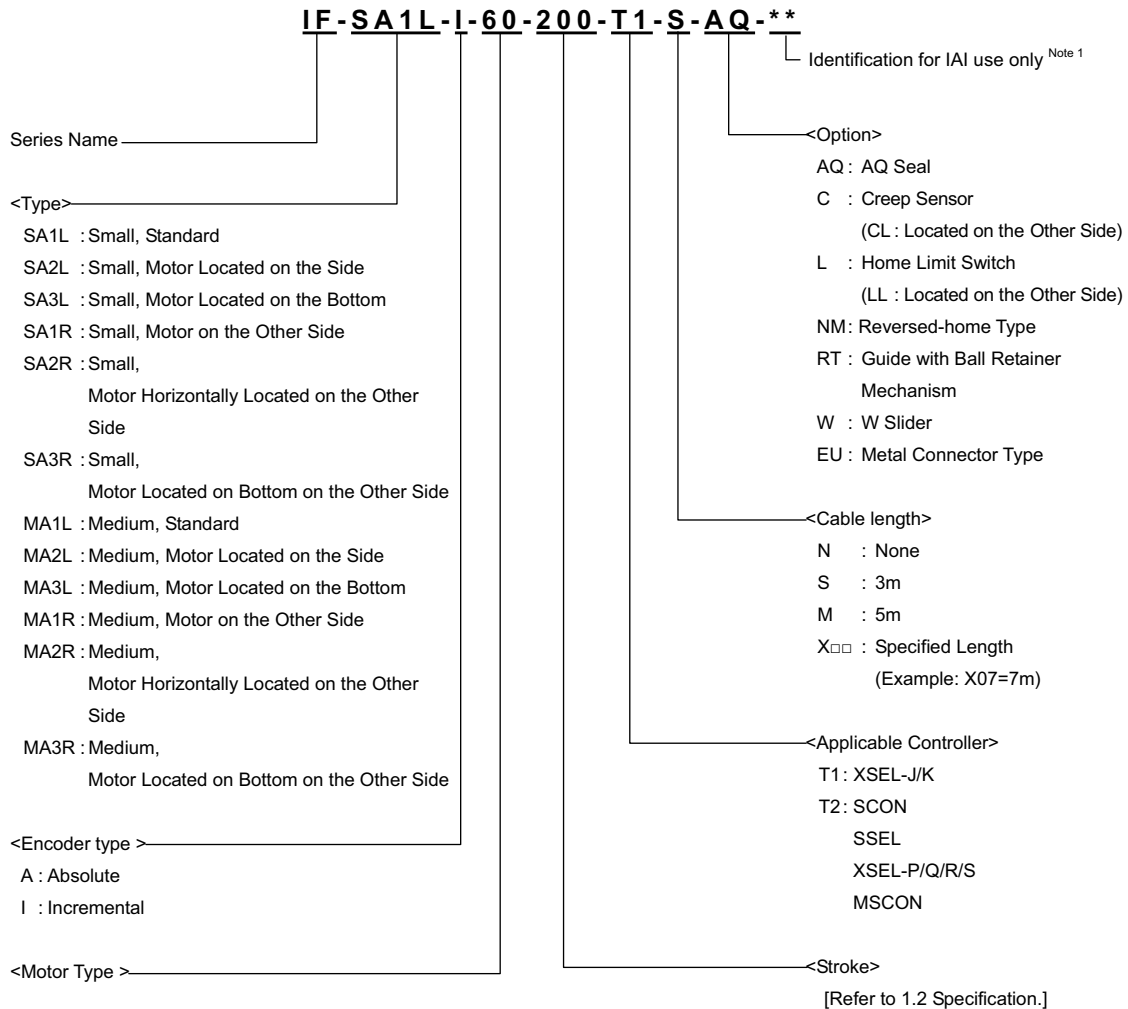

Note 1 Identification for IAI use only: This may be marked for the purpose of IAI. It is not an ID to describe the model code.

1.2 Specification

[1] Max. Speed

There is a limit in the maximum speed of the actuators.

Restriction on Speed (Unit: mm/s)

Type	Motor Type [W]	Stroke [mm]							
		300	400	500	600	700	800	900	1000
NM	60	1 to 1250							
	100	1 to 1250							

Type	Motor Type [W]	Stroke [mm]							
		300	400	600	800	1000	1500	2000	2500
WM	100	1 to 1250							
	200	1 to 1250							

Type	Motor Type [W]	Stroke [mm]				
		1000	1500	2000	2500	3000
LM	400	1 to 1250				
HM	400	1 to 2000				

[2] Max. Acceleration Speed and Transportable Weight

When the transported weight is low, the acceleration/deceleration can be increased.

Size	Slider	Motor Type [W]	Acceleration/Deceleration [G]	Transportable Weight [kg]	Rated Thrust [N]
11NM	Single	60	0.3	2	29
12NM	Double	60	0.3	9	29
11NM	Single	100	0.3	3	49
12NM	Double	100	0.3	15	49
11WM	Single	100	0.3	3	49
12WM	Double	100	0.3	15	49
11WM	Single	200	0.3	6	98
12WM	Double	200	0.3	30	98
11LM	Single	400	0.3	15	196
12LM	Double	400	0.3	60	196
11HM	Single	400	0.3	10	127
12HM	Double	400	0.3	40	127

 **Caution:** Do not have the settings of acceleration/deceleration exceeding the rated values. It may cause vibration, malfunction or shortened life.

[3] Driving System and Position Detector

Type	Motor Type [W]	No. of Encoder Pulses	Drive system
NM	60	16384 ^{*1}	Timing belt
NM	100		
WM	100		
WM	200		
LM	400		
HM	400		

[4] Positioning Accuracy

Item	Specification
Positioning Repeatability	± 0.08mm
Lost Motion	0.1mm or less

1.3 Option

1.3.1 AQ Seal

By having the AQ Seal held on the guides and ball screw, lubricant is supplied on them, which enables maintenance-free due to a multiplier effect caused by the use together with the supply of grease.

The model code is indicated with an AQ.

1.3.2 Creep Sensor

It is a sensor to enable a high-speed home-return operation.

The model code is indicated with a C.

1.3.3 Home Limit Switch

In ordinary home-return operation, “pressing method” which the actuator is pressed against the stopper and detects the Z-phase after reversed is adopted.

“Home limit switch” is an option that does not adopt this pressing method but adopts a proximity sensor to perform the home-return operation.

The model code is indicated with an L.

1.3.4 Reversed-home Type

The home is set on the side opposite the motor.

The model code is indicated with an NM.

1.3.5 Guide with Ball Retainer Mechanism

By putting a spacer (retainer) between the guides, ball (steel) and ball, noise can be lowered and the product life can be made longer at the same time.

The model code is indicated with an RT.

1.3.6 W Slider

A free slider which is not connected to the ball screw or driving belt can be added.

The model code is indicated with a W.

1.3.7 Metal Connector Type

The connectors on the motor cable and encoder cable to connect to the actuator change from plastic connectors to metal connectors.

The model code is shown as EU.

1.4 Motor • Encoder Cables

1.4.1 Standard

The cables are in common for the actuators no matter the model type. The cables differ depending on the corresponding controller.

Table for Controller and Applicable Motor • Encoder Cable

Controller	XSEL-J/K		XSEL-P/Q/R/S		SSEL		SCON, MSCON	
	Without LS	With LS	Without LS	With LS	Without LS	With LS	Without LS	With LS
Applicable Cable	1), 2)	1), 2), 3)	1), 4)	1), 5)	1), 4)	1), 5)	1), 4)	1), 5)

1) Motor Cable CB-X-MA□□□

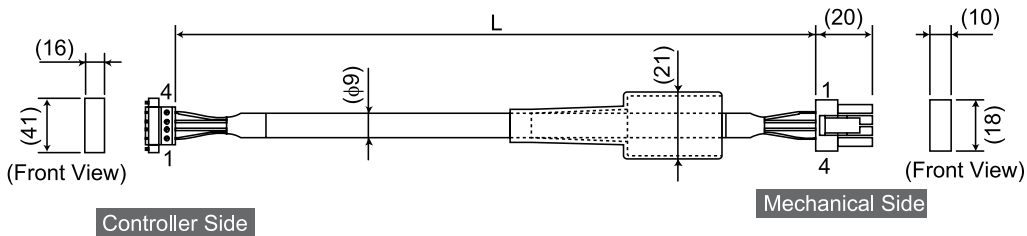

Wiring	Color	Signal	No.	No.	Signal	Color	Wiring
0.75sq	Green	PE	1	1	U	Red	0.75sq (Solderless)
	Red	U	2	2	V	White	
	White	V	3	3	W	Black	
	Black	W	4	4	PE	Green	

Enter the cable length (L) in □□□ (up to 30 m)

Example) 080=8m

[Minimum Bending Radius]

When used under moving condition : 51mm

When used in fixed condition : 34mm

2) Encoder Cable CB-X-PA□□□

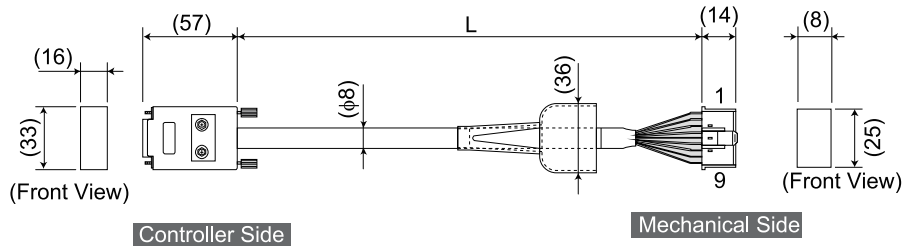

Wiring	Color	Signal	No.
	-	-	1
	-	-	2
	-	-	3
	-	-	4
	-	-	5
	-	-	6
0.15sq (Solderless)	Blue	SD	7
	Orange	SD	8
	Black	BAT+	9
	Yellow	BAT-	10
	Green	VCC	11
	Brown	GND	12
	Gray	BK-	13
	Red	BK+	14
	-	-	15

No.	Signal	Color	Wiring
1	BAT+	Black	0.15sq (Solderless)
2	BAT-	Yellow	
3	SD	Blue	
4	SD	Orange	
5	VCC	Green	
6	GND	Brown	
7	FG	Drain	
8	BK-	Gray	
9	BK+	Red	

The shield is clamped to the hood

Ground wire and braided shield wires

Enter the cable length (L) in □□□ (up to 30 m)
 Example) 080=8m

[Minimum Bending Radius]

When used under moving condition : 44mm

When used in fixed condition : 29mm

3) Limit Switch Cable CB-X-LC□□□

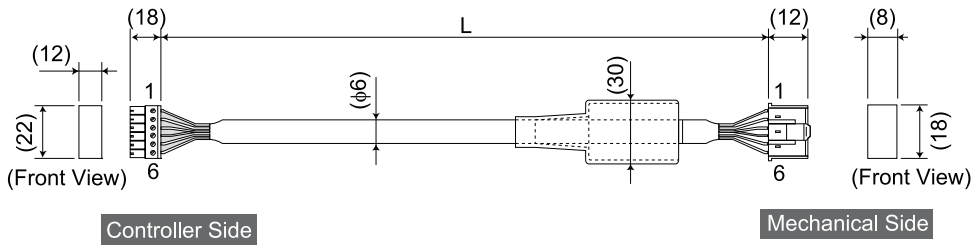

Wiring	Color	Signal	No.	No.	Signal	Color	Wiring
AWG24	Sky Blue	24VOUT	6	1	24VOUT	Sky Blue	AWG24 (Solderless)
	Pink	N	5	2	N	Pink	
	Light Green	LS	4	3	LS	Light Green	
	Orange	CREEP	3	4	CREEP	Orange	
	Gray	OT	2	5	OT	Gray	
	1B/Sky blue	RSV	1	6	RSV	1B/Sky Blue	

Note) 1B indicates one black dot mark.

Enter the cable length (L) in □□□ (up to 30 m)
 Example) 080=8m

[Minimum Bending Radius]

When used under moving condition : 33mm

When used in fixed condition : 22mm

4) Encoder Cable CB-X1-PA□□□

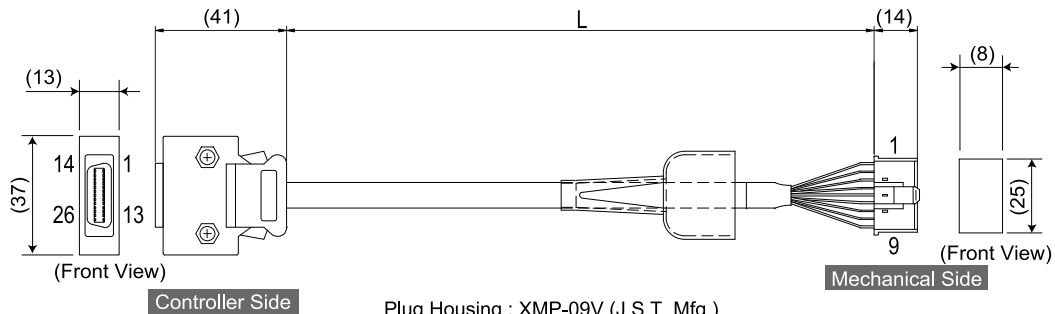

Plug Housing : XMP-09V (J.S.T. Mfg.)
 Socket Contact : BXA-001T-P0.6 (J.S.T. Mfg.) × 9
 Retainer : XMS-09V (J.S.T. Mfg.)
 Use a crimping tool recommended by the connector supplier.

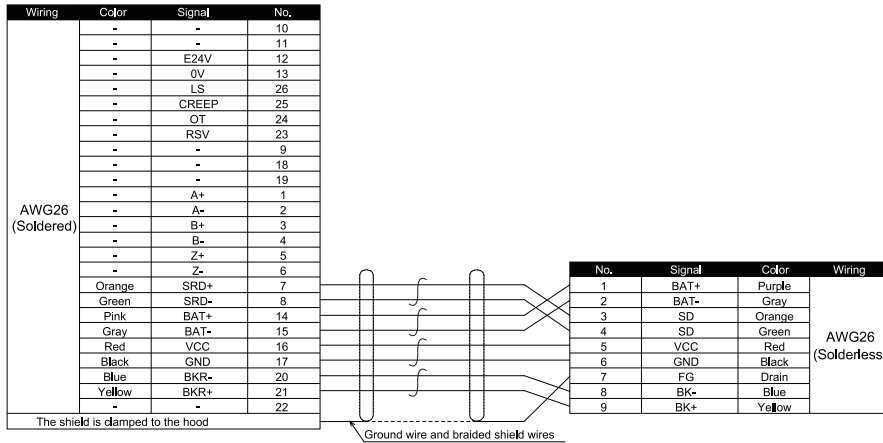

Enter the cable length (L) in □□□ (up to 30 m)
 Example) 080=8m

[Minimum Bending Radius]
 When used under moving condition : 44mm
 When used in fixed condition : 29mm

5) Encoder Cable with LS CB-X1-PLA□□□

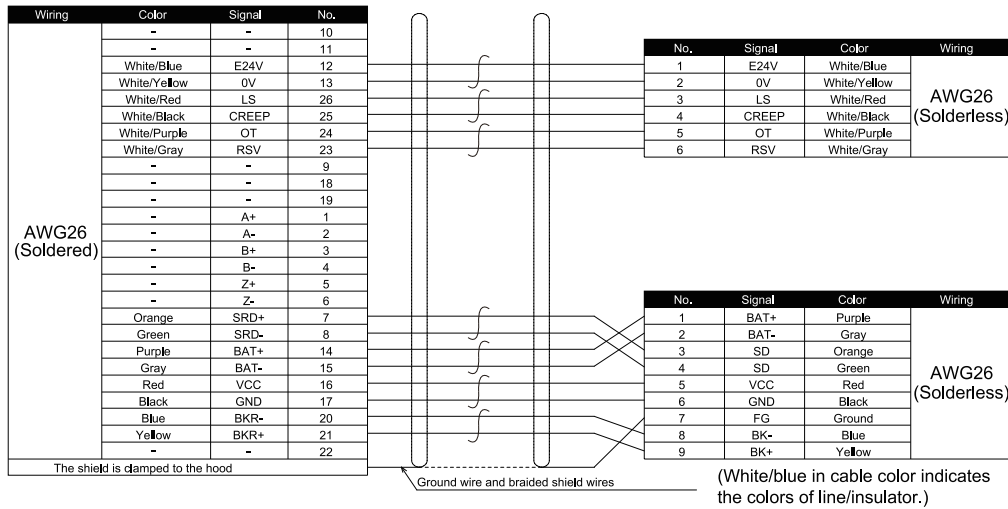
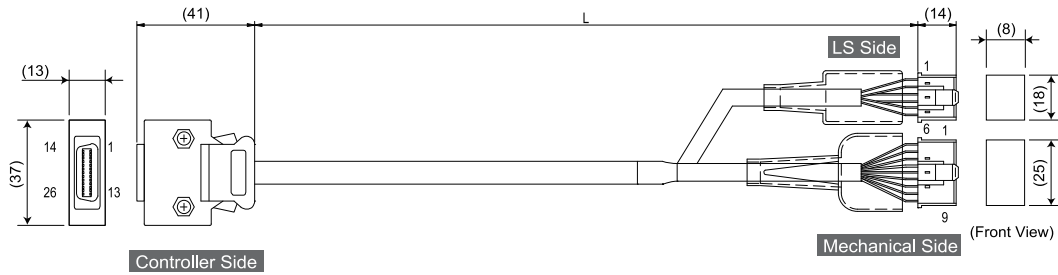

Enter the cable length (L) in □□□ (up to 30 m)
 Example) 080=8m

[Minimum Bending Radius]
 When used under moving condition : 54mm
 When used in fixed condition : 36mm

1.4.2 Metal Connector Type (Option Model code: EU)

The cables are in common for the actuators no matter the model type. The cables differ depending on whether it is with or without LS.

Table for Controller and Applicable Motor • Encoder Cable

Controller	XSEL-P/Q/R/S, SSEL, SCON, MSCON	
LS	Without LS	With LS
Applicable Cable	1), 2)	1), 3)

1) Motor Cable CB-XEU-MA□□□

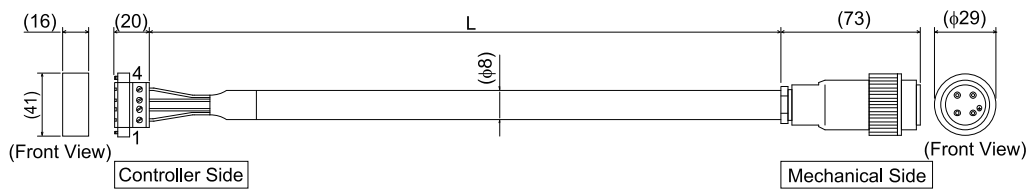

Plug GIC2.5/4-STF-7.62 (PHOENIX CONTACT)			Plug connector 99-4222-00-04 (BINDER)		
Wiring	Signal	No.	No.	Signal	Wiring
0.75sq	PE	1	⊕	PE	0.75sq (Solderless)
	U	2	1	U	
	V	3	2	V	
	W	4	3	W	

Enter the cable length (L) in □□□ (up to 30 m)
Example) 080=8m

[Minimum Bending Radius]

When used under moving condition : 48mm

When used in fixed condition : 48mm

2) Encoder Cable CB-XEU1-PA□□□

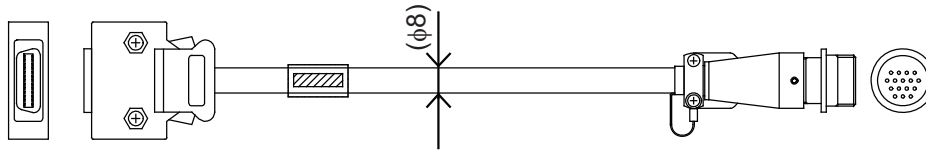

Wiring	Color	Signal	No.
-	-	-	10
-	-	-	11
-	-	E24V	12
-	-	OV	26
-	-	LS	25
-	-	CREEP	24
-	-	OT	23
-	-	RSV	9
-	-	-	18
-	-	-	19
-	-	A+	1
-	-	A-	2
-	-	B+	3
-	-	B-	4
-	-	Z+	5
-	-	Z-	6
Orange		SRD+	7
Green		SRD-	8
Purple		BAT+	14
Gray		BAT-	15
Red		VCC	16
Black		GND	17
Blue		BKR-	20
Yellow		BKR+	21
-	-	-	22

No.	Signal	Color	Wiring
1	SD	Orange	
2	SD	Green	
3	-	-	
4	-	-	
5	-	-	
6	-	-	
7	-	-	
8	-	-	
9	-	-	
10	VCC	Red	
11	GND	Black	
12	BAT+	Purple	
13	BAT-	Gray	
14			
15	BKR-	Blue	
16	BKR+	Yellow	

The shield is clamped to the hood

Ground wire and braided shield wires

Shield to be connected to earth sleeve

(White/blue in cable color indicates the colors of line/insulator.)

Enter the cable length (L) in □□□ (up to 30 m)
 Example) 080=8m

[Minimum Bending Radius]
 When used under moving condition : 44mm
 When used in fixed condition : 29mm

3) Encoder Cable CB-XEU1-PA□□□

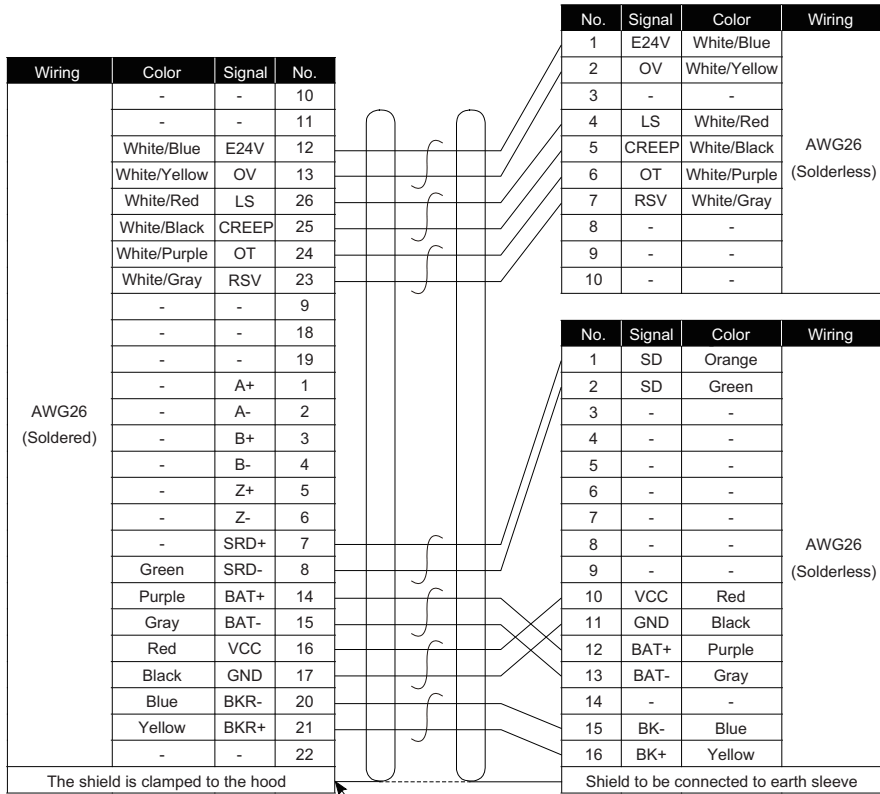
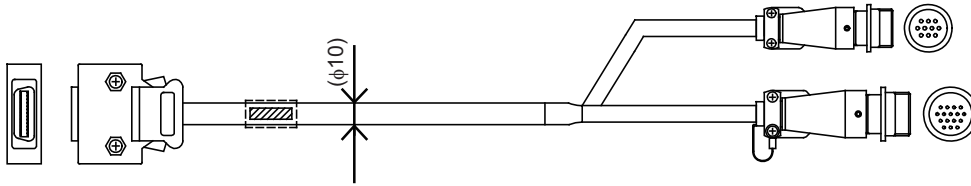

(White/blue in cable color indicates the colors of line/insulator.)

Enter the cable length (L) in □□□ (up to 30 m)

Example) 080=8m

[Minimum Bending Radius]

When used under moving condition : 58mm

When used in fixed condition : 38mm

2. Installation

2.1 Transportation

[1] Handling of the Robot

Pay attention to the following when carrying an actuator by itself.

(1) Handling of the Packed Product

Unless otherwise specified, the single axes at the delivery are packaged individually. Please concern the handling of the unit so you would not hit or drop it while carrying.

- An operator should never attempt to carry a heavy package on their own.
- If the shipping box is to be left standing, it should be in a horizontal position.
- Do not step or sit on the package.
- Do not place on the carton any heavy object that may cause the carton to deform, or an article whose shape allows a load to be concentrated at one point.

(2) Handling after Unpackaged

Do not attempt to hold the motor unit or cable when carrying the actuator, or pull the cables to move the unit.

Make sure to hold the base area when handling the unpackaged actuator.

[2] Handling of Multi-Axes Type

Pay attention to the following when carrying the actuator with the axes being attached.

(1) Handling of the Packed Product

If an order for the product was made with the axes attached, we would build the product in our factory, conduct the delivery inspection, affix on a wooden pallet and cover with the frames to deliver the product.

If the actuator to be attached is a slider type, the slider is fixed in the package so it would not accidentally move. Also for the actuator of the combined unit, the end is fixed so it would not widely shake by the external vibration.

- The package is not applied with any special treatment that enables it to resist an impact caused by a drop or crash. Handle it with care. Also, please note that the frame would not endure load on the top. Do not attempt to put load on it.
- When suspending the package using belts, pass the belts from underneath the reinforcement frames at the bottom of the base. When lifting with a forklift, also place the forks underneath the base.
- Handle with care not to apply shock when putting it down.

(2) Handling after Unpackaged

After unpackaged, handle the product that axes were attached in IAI factory following the instructions below:

- Fix the sliders during transportation so they would not move accidentally.
- Appropriately fix the end of the actuators if it is overhanging so it would not widely shake with external vibration. If the actuator assembly is transported without the ends being secured, do not apply an impact of 0.3G or more.
- In such cases as hanging the peripherals including the actuators with a belt, do not attempt to attach the belt directly to the actuators and avoid the belt being touch the actuators.
- Apply appropriate shock-proof methods to the belt and set it so the base part receives the load.
- For Y-axis, support the end with another belt to maintain the stable horizontal orientation. At the same time, pay attention not to apply load to the screw cover.
- Do not attempt to apply load to the brackets, covers or connector box mounted on the main body.

Also, avoid the cables being pinched or caused an excessive deformation.

[3] Handling of the Robot Mounted on Mechanical Equipment (System)

When peripheral devices were attached by the customer and the unit is to be carried, also follow the instructions described in [5.2.2 handling in unpackaged condition] for appropriate handling.

2.2 Installation and Storage Environment

[1] Installation

Do not use this product in the following environments.

It is generally the environment where a worker can work without any protection gear.

Also make sure to keep enough work space necessary for maintenance.

- Location exposed to radiant heat from a huge heat source such as the heat treatment
- Location where the surrounding air temperature exceeds the range of 0 to 40°C
- Location where condensation occurs due to abrupt temperature changes
- Location where relative humidity exceeds 85%RH
- Location exposed to direct sunlight
- Location exposed to corrosive gases or combustible gases
- Location exposed to significant amount of dust, salt or iron powder (Outside of an ordinary assembly plant)
- Location where water, oil (includes oil mist and cutting fluid) or a chemical is splashed
- Location where the product main body receives vibration or hit impact

When using the product in any of the locations specified below, provide a sufficient shield.

- Place subject to electrostatic noise
- Location where exposed to the influence of strong electric or magnetic field
- Location where exposed to the influence of ultraviolet or radiant rays

[2] Storage and Preservation Environment

- The storage and preservation environment should comply with the same standards as those for the installation environment. In particular, when the machine is to be stored for a long time, pay close attention to environmental conditions so that no dew condensation forms.
- Unless specially specified, moisture absorbency protection is not included in the package when the machine is delivered. In the case that the machine is to be stored and preserved in an environment where dew condensation is anticipated, take the condensation preventive measures from outside of the entire package, or directly after opening the package.
- For storage and preservation temperature, the machine withstands temperatures up to 60°C for a short time, but in the case of the storage and preservation period of 1 month or more, control the temperature to 50°C or less.
- Storage and preservation should be performed in the horizontal condition. In the case it is stored in the packaged condition, follow the posture instruction if any displayed on the package.

2.3 How to Install

Shown below is how to install the actuators to the machinery equipment.



2.3.1 Orientation of the Actuator Installation

Shown below are the basic concepts for the product attachment. Pay special attention when deciding how to install the product (Except with custom-order models).

○ : Available △ : Precautions observing strictly × : Not available

Horizontal installation	Vertical Mount	Sideways installation	Ceiling mount installation
○	×	×	△

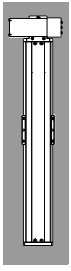
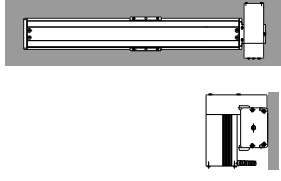
Installation orientation

Horizontal	Vertical	Sideways	Ceiling mount
			

 **Caution:** In the ceiling mount installation, the screw cover may bend, and it will be likely to interfere with the work part. When the stroke is 900mm or more, attach the work piece away from the surface in Distance A.

Stroke [mm]	Distance A [mm]
900 or more less than 1400	5 or more
1400 or more less than 2100	10 or more
2100 or more less than 2400	15 or more
2400 or more less than 2400	20 or more

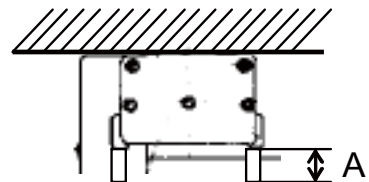

2.3.2 Installation

[1] Installation of Main Unit

(1) Datum Surface

- The mounting table should have sufficient rigidity to avoid generating vibration.
- The surface where the actuator will be mounted should be a machined surface or that with an accuracy equivalent to it, and the flatness should be 0.05mm or below.
- Have enough space for the maintenance work.
- The side and bottom surfaces of the base on the actuator work as the datum surfaces for the side of the slider
- Use these surfaces as the datum surfaces for mounting.

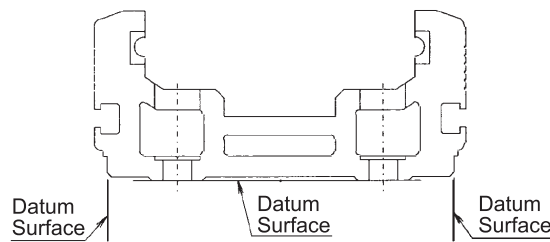

Caution: As shown in the figure above, the surfaces on the base sides are datum surfaces for the slider movement. Utilize these faces when accuracy is required to the operation.

Please follow the diagrams below for machining to mount on to the frame using the base surface:

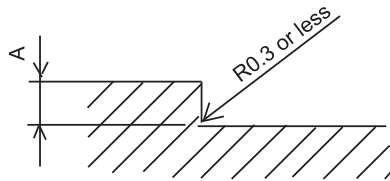

Model	A Dimension [mm]
S Type	2 to 5
M Type	2 to 5

(2) Mounting method

- There is a set hole on the actuator base. Fix the actuator using this set hole.
- The belt cover can be removed using the hexagon wrench with the distance to the opposite side of 2 mm.
- For the set bolt, use hexagon socket head cap screw with the intensity classification of 10.9 or more and fasten it with the attached special washer.

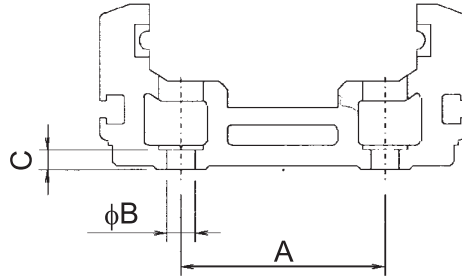

Model	A	B	C	Mounting screw
S Type	50mm	7	5mm	M6
M Type	70mm	9	6mm	M8

⚠ Caution: Make sure to use the attached special washer. If the actuator is mounted without using this washer, the bolt might be loosened due to the buckling on the bolt-seated surface.

- Use a hex socket head cap screw for the attachment to the base.
- It is recommended to use high-tensile bolts with ISO-10.9 or more.
- Make sure to have the effective length of screw engagement described below or more for the tightening of a bolt and a female screw.
 - When female screw is on steel → thread length same as nominal diameter
 - When female screw is on aluminum → thread length 2 times longer than nominal diameter
- When using a bolt sized M8 or more and the seat for the bolt is made of aluminum, apply a washer dedicated for high-tensile bolts (otherwise the bolt seat may sink). It is not necessary if the bolt is M6 or smaller. Please do not apply a standard spring lock washer.

The recommended screw torque is given below.

Screw nominal diameter	Tightening Torque	
	In the case that steel is used for the bolt seating surface:	In the case that aluminum is used for the bolt seating surface:
M5	7.5N·m (0.77kgf·m)	4.3N·m (0.44kgf·m)
M6	12.9N·m (1.32kgf·m)	6.7N·m (0.68kgf·m)
M8	31.3N·m (3.19kgf·m)	14N·m (1.43kgf·m)

[2] Load Installation

- Do not exceed the load shown in the load specification column. Please make note of the slider moment, allowable overhang length and the load weight.
- When it is used as the Y-axis in the cantilever X-Y combination, it is easy to deform the base itself. Therefore, use it with the M_c moment lowered to 1/2 or less of the rated value. (Refer to table below.)

Dynamic Allowable Moments

Model	M_a	M_b	M_c
S Type	32.9N·m (3.36kgf·m)	47.0N·m (4.8kgf·m)	76.8N·m (7.84kgf·m)
M Type	81.0N·m (8.27kgf·m)	116.0N·m (11.84kgf·m)	189.0N·m (19.29kgf·m)

Allowable Overhang Length

Model	M_a direction	M_b direction	M_c direction
S Type	450 or less	450 or less	450 or less
M Type	600 or less	600 or less	600 or less

- The center of gravity for the mounted object is at the halfway point of the overhang length.

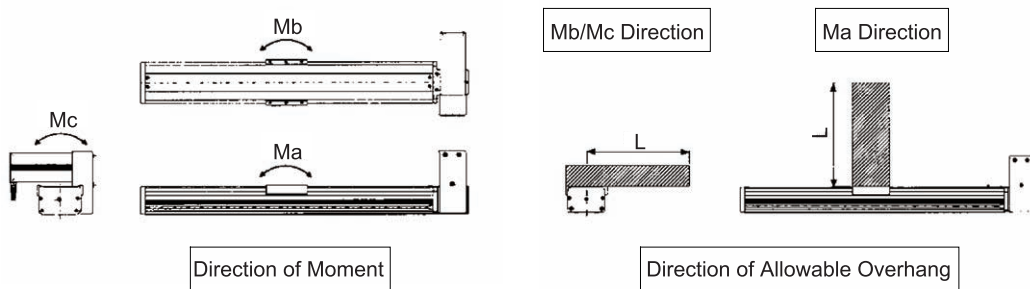

⚠ Caution: When any excessive load moment is given, some influenced including shortened guide life cycle, might be exerted. Also, when the projected length exceeds the allowable value, vibration might be caused or adverse effect might be caused in the guide life cycle.

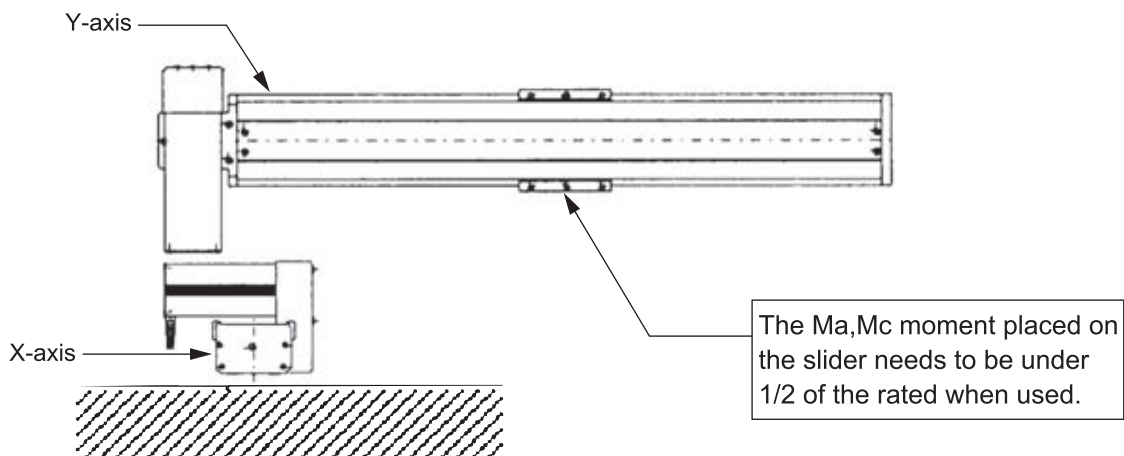

- There are tapped holes in the slider where you can affix the payload.
The way to affix follows the installation of the main unit.
- If you are anchoring the slider and moving the main body, attach the slider using the tapped holes.
- The slider has two reamed holes which are used to reproduce the correct positioning when dismantling and reattaching the slider. Also, if you require precision in your attachment, such as a right angle, use the reamed hole to make fine adjustments.

Slider Tap Hole Diameter and Reamer Diameter

Model	Tapped Holes	Tap depth	A	B	C	Reamed Hole	Reamed Depth
S Type	M6	20mm	70mm	-	90mm	φ6H10	10mm
M Type	M6	20mm	-	70mm	120mm	φ8H10	10mm
	M8	20mm	90mm	-			

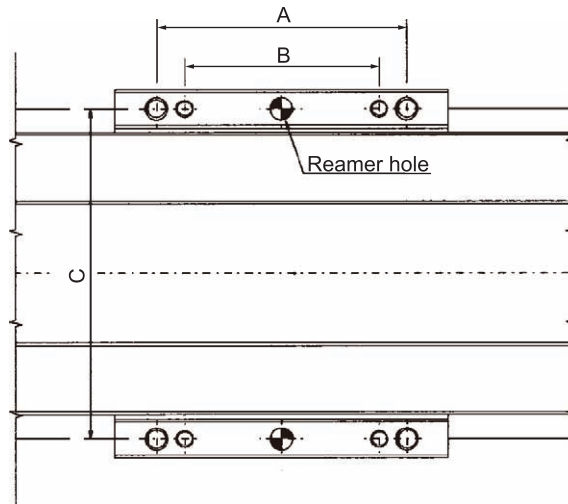

[3] Mounting and the T-Slot (Option)

There is a T-groove on the side surface of the base provided to mount a connector box or cable track retainer that is necessary when assembling the system. When using the cable wiring kit for assembly, utilize the T-groove for mounting. Use the slots as necessary to mount sensors or to anchor cables.

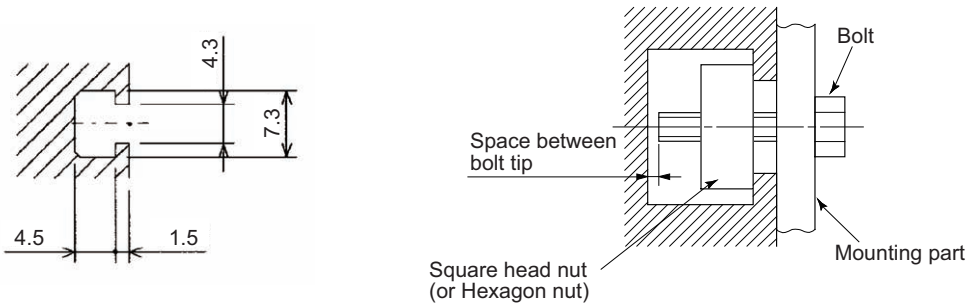

-  **Caution :**
- We recommend a square nut for the T-slot but you can also use a hexagonal nut.
 - When mounting, check the bolt length to make sure the end does not touch the bottom of the T-slot.

3. Connection to the controller

For the controller, only the dedicated controller manufactured by our company can be used. Use the dedicated cable enclosed in the package when connecting the actuator and the controller.

[1] Standard cable

[Connection to the XSEL-J/K controller]

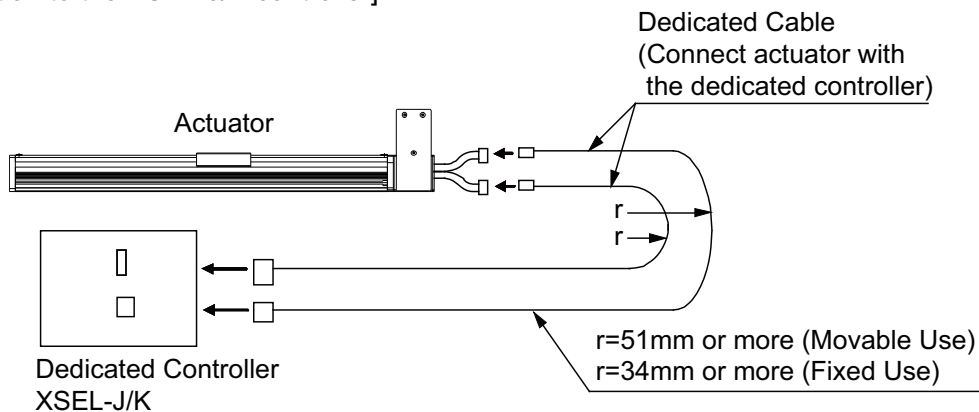

- Motor Cable CB-X-MA□□□
 - Encoder Cable CB-X-PA□□□
 - Limit Switch Cable CB-X-LC□□□
- shows the cable length.
The max. length should be 30m.
Example) 080=8m

[Connection to the XSEL-P/Q/R/S, SSEL, SCON and MSCON controller]

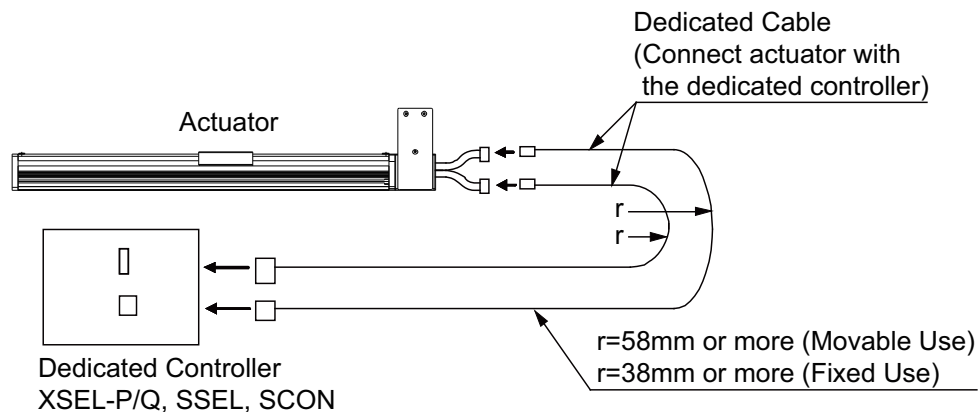

- Motor Cable CB-X-MA□□□
 - Encoder Cable CB-X1-PA□□□
 - Encoder Cable with LS CB-X1-PLA□□□
- shows the cable length.
The max. length should be 30m.
Example) 080=8m

[2] Metal Connector Type Cable

[Connection to the XSEL-P/Q/R/S, SSEL, SCON and MSCON controller]

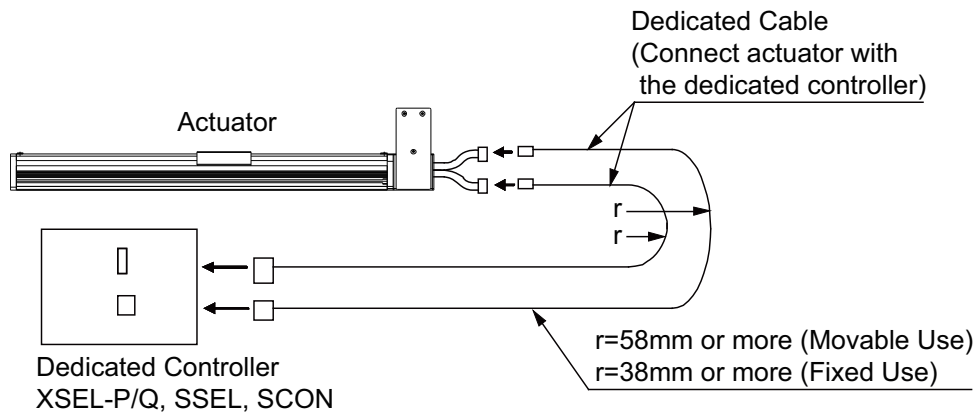

- Motor Cable B-XEU-MA□□□
- Encoder Cable CB-XEU1-PA□□□
- Encoder Cable with LS CB-XEU1-PLA□□□

□□□ shows the cable length.
 The max. length should be 30m.
 Example) 080=8m



Warning : For wiring, please follow the warnings stated below. When constructing a system as the machinery equipment, pay attention to the wiring and connection of each cable so they are conducted properly. Not following them may cause not only a malfunction such as cable breakage or connection failure, or an operation error, but also electric shock or electric leakage, or may even cause a fire.

- Use dedicated cables of IAI indicated in this instruction manual. Contact us if you wish to have a change to the specifications of the dedicated cables.
- Make sure to turn the power off in the process of power line or cable connection or disconnection.
- Do not attempt to cut a dedicated cable with connectors on both ends to extend, shorten or re-joint it.
- Hold the dedicated cable to avoid mechanical force being applied to the terminals and connectors.
- Use a cable pipe or duct to have an appropriate protection when there is a possibility of mechanical damage on a dedicated cable.
- In case a dedicated cable is to be used at a moving part, make sure to lay out the cable without applying any force to pull the connector or extreme bend on the cable. Do not attempt to use the cable with a bending radius below the allowable value.
- Make certain that the connectors are plugged properly. Insufficient connection may cause an operation error, thus it is extremely risky.
- Do not lay out the cables to where the machine runs over them.
- Pay attention to the cable layout so it would not hit peripherals during an operation. In case it does, have an appropriate protection such as a cable track.
- When a cable is used hanging on the ceiling, prevent an environment that the cable swings with acceleration or wind velocity.
- Make sure there is not too much friction inside the cable storage equipment.
- Do not apply radiated heat to power line or cables.
- Have a sufficient radius for bending, and avoid a bend concentrating on one point.

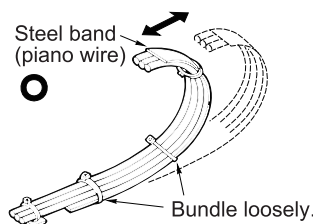
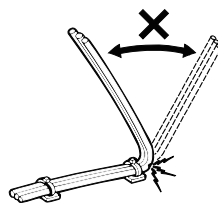

- Do not let the cable bend, kink or twist.

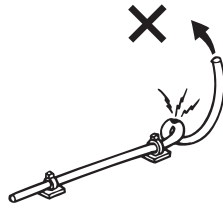

- Do not pull the cable with a strong force.

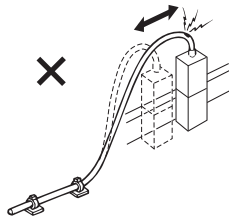

- Pay attention not to concentrate the twisting force to one point on a cable.

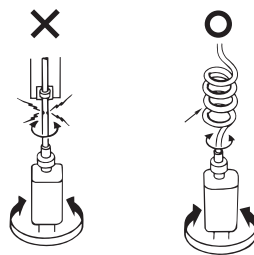

- Do not pinch, drop a heavy object onto or cut the cable.

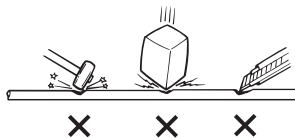

- When a cable is fastened to affix, make sure to have an appropriate force and do not tighten too much.

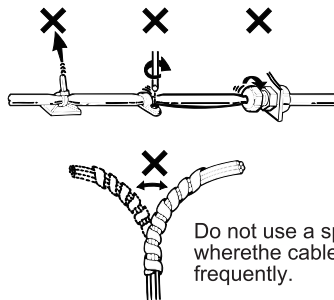

Do not use a spiral tube where the cable flexes frequently.

- PIO line, communication line, power and driving lines are to be put separately from each other and do not tie them together. Arrange so that such lines are independently routed in the duct.

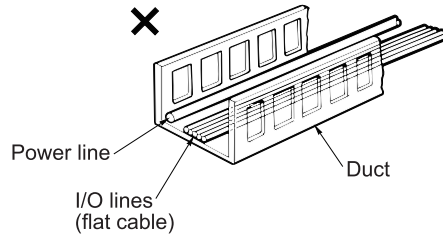

Follow the instructions below when using a cable track.

- If there is an indication to the cable for the space factor in a cable track, refer to the wiring instruction given by the supplier when storing the cable in the cable track.
- Avoid the cables to get twined or twisted in the cable track, and also to have the cables move freely and do not tie them up. (Avoid tension being applied when the cables are bent.) Do not pile up cables. It may cause faster abrasion of the sheaths or cable breakage.

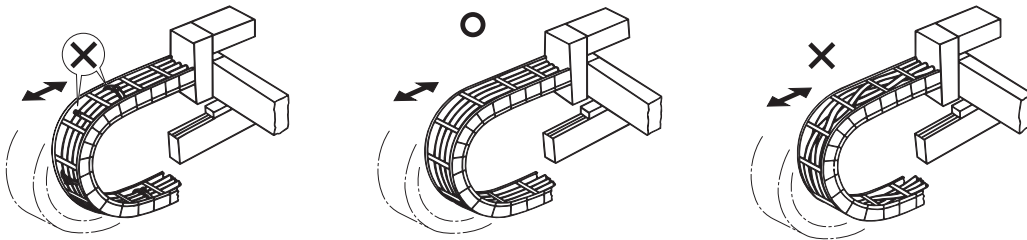

4. Setting the Home Position

[1] The Principle of the Homing Operation

The Actuator performs homing in the following manner:

- 1) The moving direction is determined by the parameters set by the homing command.
- 2) It detects the mechanical end with the software in the home return operation.
- 3) The slider reverses direction when this end is reached and the place where the Z-phase signal is detected becomes the reference point.
- 4) The slider travels further by an offset amount defined by the parameters and this position becomes home.

[2] Fine Control of the Home Position

The number of motor revolutions from the time the slider hits the stopper to when the Z-phase signal is generated is adjusted when the unit is shipped.

The standard value of the backing distance when the slider hits the stopper, reverses and then stops at the home position is,

Model	Reverse distance from the mechanical end [Approx. mm]
S Type	10
M Type	10

As long as the homing direction is the same, you can make fine adjustments to the home position for each actuator by changing the parameters based on this value. Adjustments are made as follows:

- 1) Initiate the homing operation and confirm home.
- 2) After that, move to the desired home position, check the difference and adjust the parameters (For the E/G controller, any negative value is not acceptable).
- 3) If you allow for ample offset amount the movement range is that much more limited.
If the offset is greater than 1mm, you will have to reset the stroke soft limit.

[3] Changing the Home Direction

If you need to change the home direction after the unit is delivered, the move direction parameter must be changed and you may need to adjust the encoder Z-phase so please contact IA. Also, the homing direction can not be changed by your company when it has the double slider.

[4] Alignment Marks Affixation

Make sure to affix the alignment marks on the slider and base so that the home position can be confirmed. It is necessary as the reference position when the positional deviation is confirmed because of the timing belt tooth missing or in the case of the motor change.

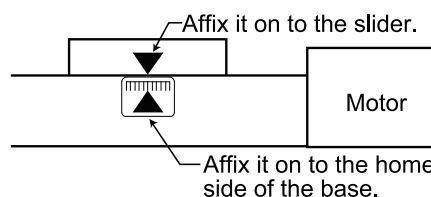

5. Maintenance inspection

5.1 Inspection Items and Inspection Schedule

Have maintenance inspections following the intervals below.

8 hours per day is assumed as operation condition

Have inspections more frequently if the operation frequency is high for night and day continuous operation, etc.

	Visual inspection	Internal Check	Grease supply ^{*1}
At startup inspection	○		
1 month after start of operation	○		
6 months after start of operation	○	○	
1 year after start of operation	○	○	○
Every 6 months thereafter	○		
Every year thereafter	○	○	○

^{*1} If the actuator is operated back and forth repeatedly over a distance of 30 mm or less, the oil film created by the grease may be broken. It is recommended to have 5 cycles of back and forth operation in a distance more than 50mm after every 5,000 to 10,000 rounds of the short distance operation. A layer of the grease will recover.

5.2 Visual inspection

Conduct the item below in the visual inspection.

Main Body	Looseness of attachment screws
Cables	Scratches, proper connection of connectors
Overall	Vibration, Abnormal noise

5.3 Cleaning

- Please clean the external body on a regular basis.
- When cleaning, wipe with a soft cloth to remove dust and dirt.
- Do not blow compressed air so dust would not get in from gaps.
- Do not apply petroleum solvent since it may damage the resin or painted surfaces.
- When extremely dirty, wipe it off firmly with cloth that a neutral detergent or alcohol is applied on.

5.4 Internal Inspection

Turn the power OFF. Remove the belt cover and pulley cover, and visually inspect the interior. Conduct the item below in the internal inspection.

Main Body	Looseness of attachment screws
Guide Part	Condition and dirt of lubricant
Timing Belt	Driving Belt : Scratch and tension confirmation
	Deceleration Belt : Scratch and tension confirmation
Rear Side of the Belt Cover	Condition of lubricant

The Belt cover can be detached with a 2mm-sized hex wrench and the pulley cover with a 2mm-sized or 1.5mm-sized hex wrench.

Visually inspect the inside condition. In the inspection, it should be checked if dust is involved inside and the condition of the lubricant.

Even if the grease looks brown, it will be fine as long as the sliding area seems wet and shiny. When the grease looks dirty and dull due to dust or wear due to the use for a long time, replenish grease after cleaning.

Refer to Item 5.7 Check Items for the timing belt check.

- Grease Check on the Rear Side of the Belt Cover
Check the lubricating condition on the rear side of the belt cover and belt cover support (made of resin) located at the center of the slider so that the frictional resistance between the slider and belt cover is reduced to move the slider smoothly.
When there is too little grease, replenish it.
Grease to be used: Multemp LRL 3 manufactured by Kyodo Yushi or equivalent

Belt Cover Support

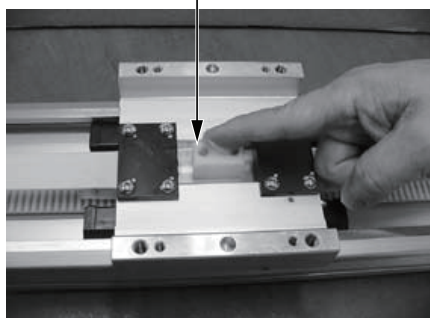

On the Rear Side of the Belt Cover

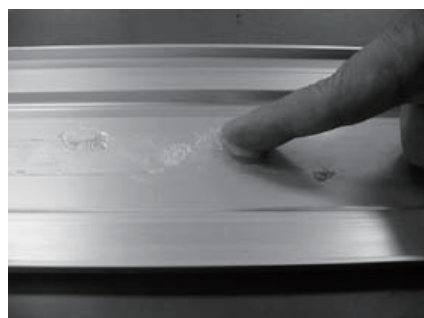

5.5 Internal Cleanup

- When cleaning, wipe with a soft cloth to remove dust and dirt.
- Do not blow compressed air so dust would not get in from gaps.
- Do not use petroleum-based solvents, neutral detergents or alcohol.

5.6 Grease Supply

(1) Applied Grease

Use lithium grease no. 2.

The following grease is applied when the product is shipped out from IAI factory.

Guide	Idemitsu Kosan	Daphne Eponex Grease No. 2
-------	----------------	----------------------------

Apart from above, there are equivalent sorts of grease sold in the market. For details contact a grease supplier, provide the grease name shown above and ask them to select an equivalent. Listed below are some equivalents for an example.

Showa Shell Sekiyu K. K.	Alvania Grease S2
Mobil Oil	Unirex N2

 **Warning:** Do not attempt to apply fluorine grease. When mixed with lithium grease, not only decrease the grease characteristics, but also may damage the actuator.

(2) Grease Supply

Use the two grease nipples on the slider end area for lubrication. Grease is replenished with the belt cover removed.

- 1) Squirt the grease from the grease nipple using a grease gun (Please see drawing below).
- 2) Also, inject the grease into the other grease hole (Inject both the left and right holes).

Model	Grease supply volume (reference)
S	1cc to 1.5cc
M	2cc to 2.5cc

Make sure to use a grease gun that is applicable for the grease nipple inlet diameter shown below.

Nipple inlet diameter	Recommended grease gun	Nozzle	Supplier
$\phi 6$	MG70	N model	THK

- 3) Move the slider back and forth several times by hand.
- 4) Repeat the lubrication one more time.
- 5) Wipe off the excessive grease.

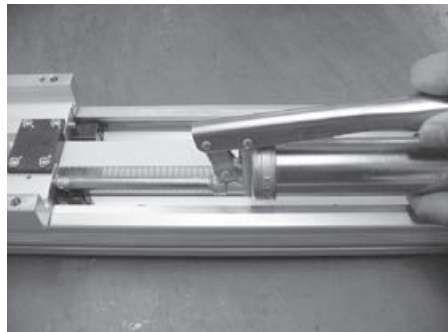
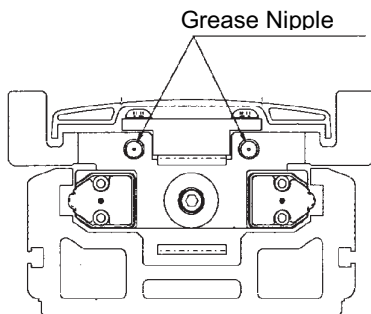

 **Caution:** In case the grease got into your eye, immediately go see the doctor to get appropriate care. After finishing the grease supply work, wash your hands carefully with water and soap to rinse the grease off.

5.7 How to Inspect the Timing Belt

Visual inspection is done by removing the belt cover and pulley cover. Since the timing belt wear largely depends on the operational requirements, as a rule, replacement period can not be determined. Generally speaking, the life span of the timing belt is the life span of a couple hundred thousand revolutions. As an actual replacement period standard, the timing belt is replaced when the following symptoms are confirmed.

When belt replacement is necessary, please contact our technical service department or sales representative (due to detailed specification differences, please always contact IAI when replacing the timing belt).

- When the gear and belt area show obvious friction.
- When swelling occurs as a result of oil adhesion.
- When damages such as a crack occurs on the belt gear and back side.
- When the belt breaks.

When installing an actuator, ensure as much working space as it can be secured to perform a work to remove the screws holding the pulley cover and to remove the belt cover so the timing belt can be inspected and adjusted.

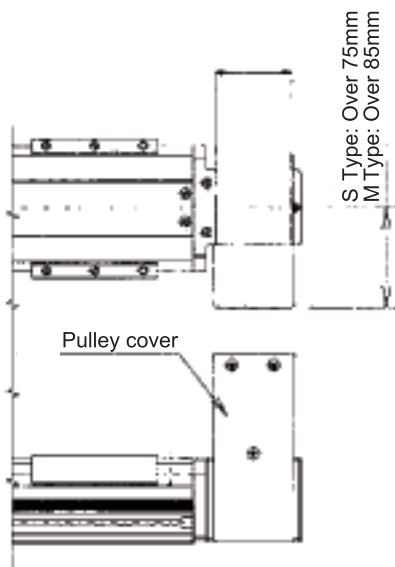

The table below shows the types of timing belt that we use.

Model	Belt-Drive Type	Timing Belt	Supplier
S Type	S3M, 18-wide	S3M24, 15-wide	Bandoh Kagaku, Inc.
M Type	S5M, 25-wide	S3M339, 20-wide	Bandoh Kagaku, Inc.

5.7.1 Belt Tension Adjustment Method

Since inadequate belt tension will lead to location drift due to gear skipping, noise occurrence as well as cause the motor to breakdown, proper tension adjustment is required.

[How to Adjust the Timing Belt:]

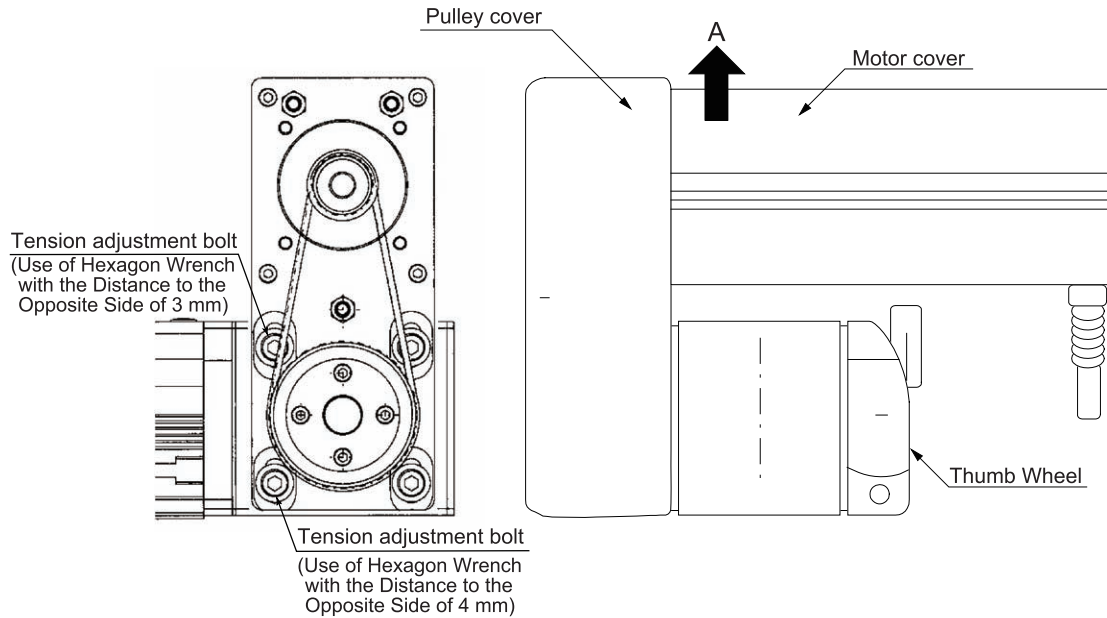

Remove the pulley cover, loosen the 4 tension adjustment bolts and lift the motor cover up to place the appropriate axis load onto the belt, and tighten the 4 tension adjustment bolts (see chart below).

For the tension loads, comply with the standards below.

Model	Axis load : A
S Type	5kgf
M Type	10kgf

[How to Adjust the Driver Belt Tension:]

Driver belt tension adjustment is done using the front cover adjustment bolt.

Since the adjustment bolt is fixed using the hexagonal nut, when adjusting, loosen the hexagonal nut, then adjust the adjustment bolt as is. Upon adjustment, tighten the hexagonal nut once again.

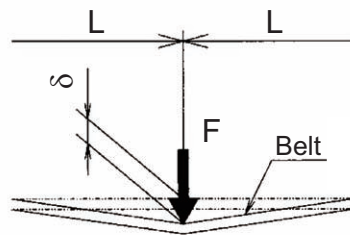
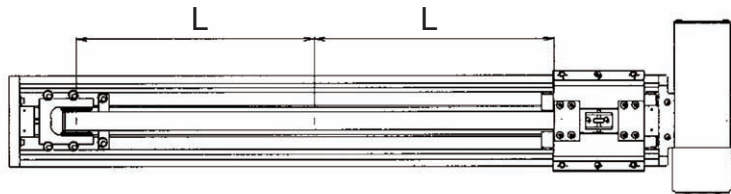
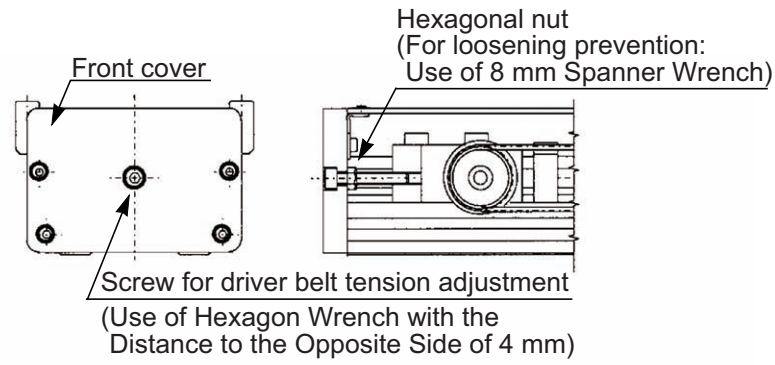

Because the deflection varies depending on the stroke, calculate the deflection δ using the following formula.

Model	Flexible load : F	Flexure : δ
S Type	0.8kgf \pm 10%	$\delta = 0.032L$
M Type	1.8kgf \pm 5%	

5.8 How to Replace the Timing Belt

[Items Required for Replacement Work]

- Replacement Driving Belt
- Packing Tape
- 8 mm Spanner Wrench
- Hexagon Wrench Set
- Push-Pull Gauge and Square
- Personal Computer or Teaching Pendant
- Tension Gauge (Tension of 10 kgf or more available)
- Strong Thread (or Long Harness Belt)

[Replacement Operation Outline]

- 1) Loosen the tension adjusting bolt and replace the belt. Then, tighten the adjusting bolt until the specified tension value is reached.
- 2) Perform the homing operation.
Loosen the deceleration belt and then, move the slider to the mechanism end and fix it. Then, fix the motor shaft at the position about 90 degrees deviated from the counter mark and adjust the deceleration belt to reach the specified tension value.
- 3) Perform the homing operation using the personal computer or teaching pendant and confirm the deviation from the original home position. If there is any deviation, adjust it using the home offset value in the parameters.
(Note) For the home offset for E/G controller, any negative value can not be entered.
Therefore, deviate the position slightly less than 90 degrees.

[Procedure]

- 1) Confirm the motor shaft rotating direction when the slider is moved from the home position to the mechanism end.
(The rotating direction varies depending on the motor installation position. Therefore, the confirmation is always required).

- Remove the pulley cover.
(Use a hexagon wrench with the distance to the opposite side of 1.5 mm for IF-S or 2 mm for IF-M).



- Confirm the motor shaft rotating direction.

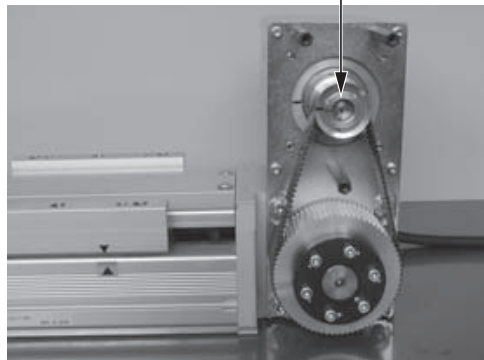

- 2) Remove the belt cover.
Remove the machine set screw (4 locations) on the motor side and also the opposite side.
(Use a hexagon wrench with the distance to the opposite side of 2 mm).

[Motor Side]



[Opposite Side]

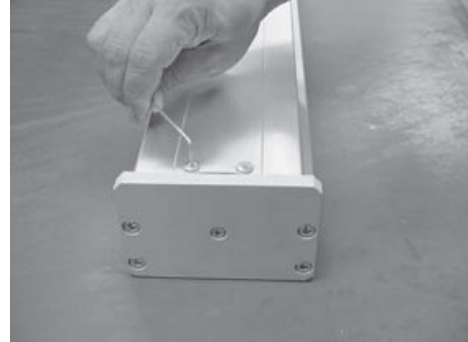

- 3) Loosen the belt tension until the pulley is turned without making contact.

- Fix the hexagon nut using the 8 mm spanner wrench.

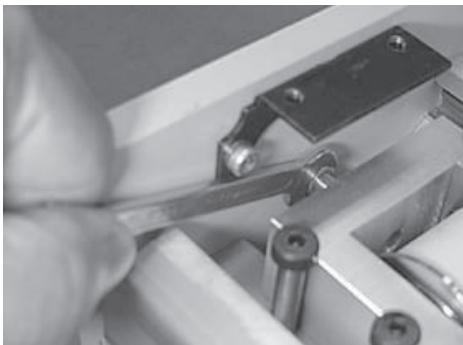

- Loosen the adjusting bolt.
(Use a hexagon wrench with the distance to the opposite side of 4 mm)

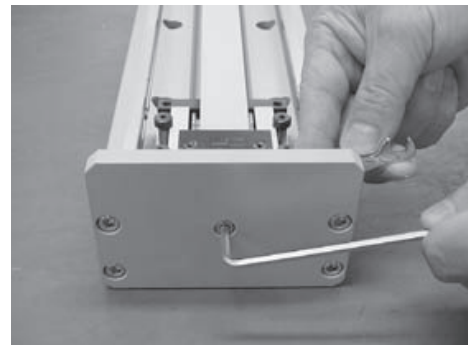



- 4) Remove the belt holding plate (2 locations). (Use a hexagon wrench with the distance to the opposite side of 3 mm for IF-3 or 4 mm for IF-M).

- Condition where the Belt Holding Plate has been removed

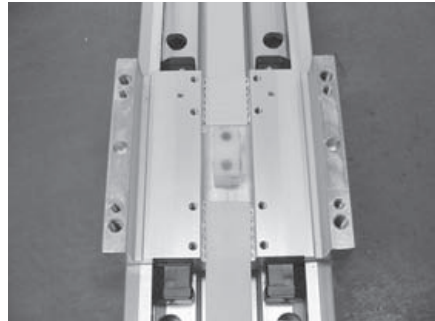
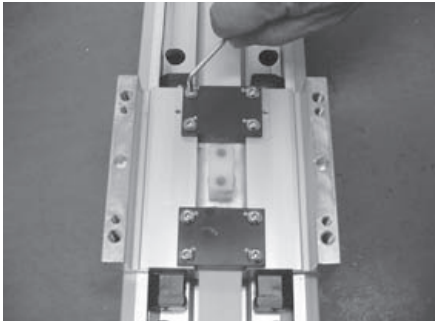

- Condition where the Both Belt Ends are released.

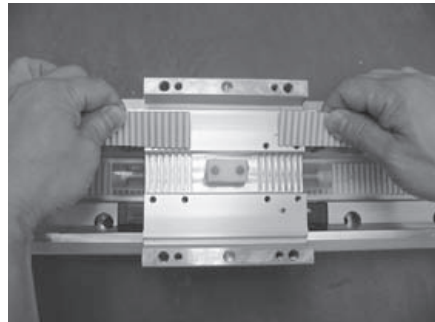

5) Replace the belt.

- Connect the replacement belt to the current belt using the packing tape.

Replacement Belt Current Belt

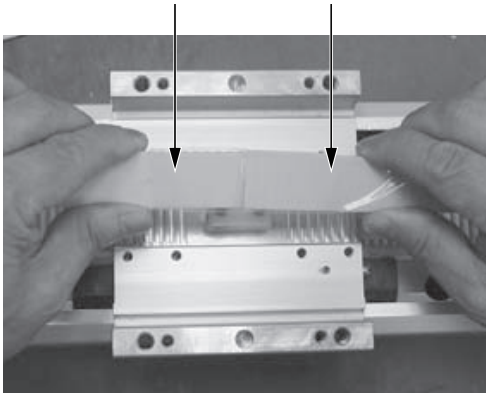

- Pull out the current belt.

Current Belt Replacement Belt

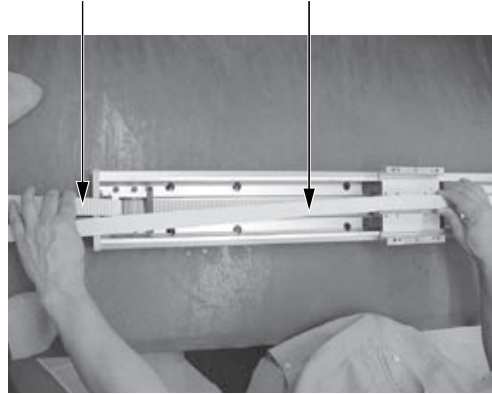

- Align the both ends of the replacement belts with the attachment teeth. (Confirm that they are aligned perfectly).

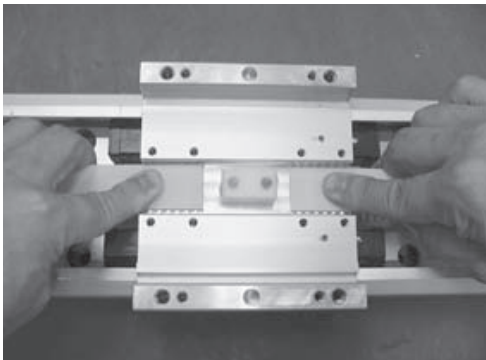

- Separate the replacement belt from the current belt.

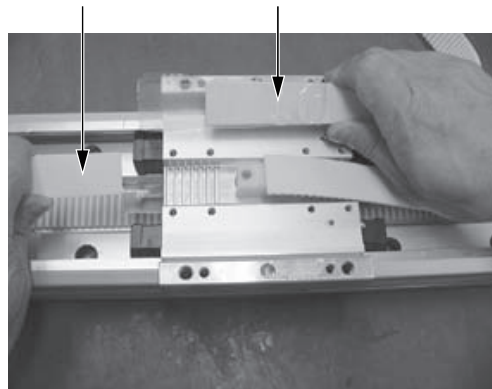

- Attach the belt holding plate (2 locations).

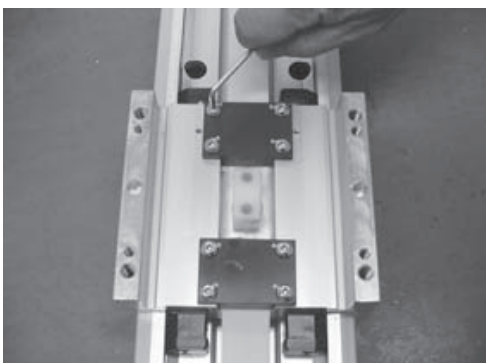

Tightening Torque: 20 kgf for IF-S and 45 kgf for IF-M

6) Adjust the belt tension until the specified tension value is reached.

- Move the slider to the mechanism end on the motor side.
Measure the distance from the slider side to the pulley center and mark the central position.

Measure this distance and find the central position.

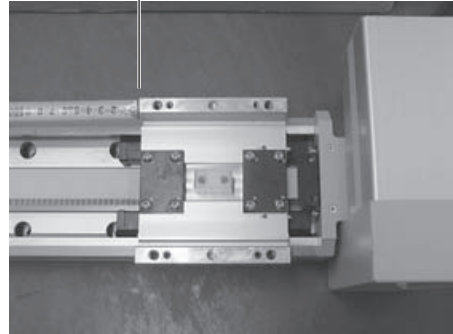
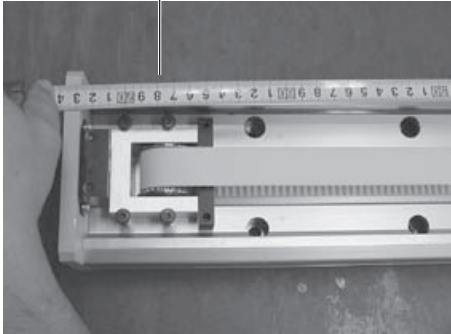

- Press the push-pull gauge against the central position and tighten the adjusting bolt so that the specified values for the deflection load and deflection are reached. (Refer to “How to Adjust the Driver Belt Tension” for the specified values).

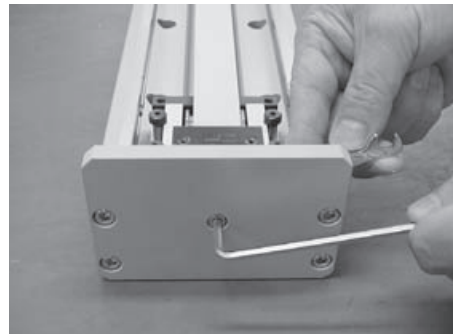

- Tighten the hexagon nut securely.

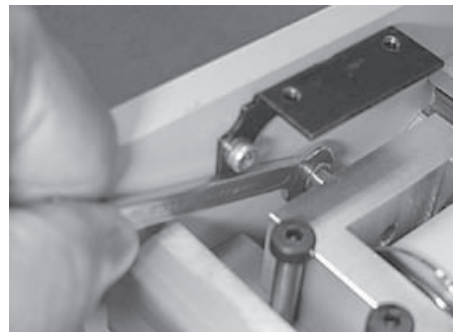

7) Attach the belt cover.

8) Adjust it to recover the home position.

- Remove the pulley cover and loosen the bolt fixing the motor bracket using the hexagon wrenches with the distance to the opposite side of 3 mm and 4 mm. Then, slide the motor belt until the pulley is turned without making any contact.

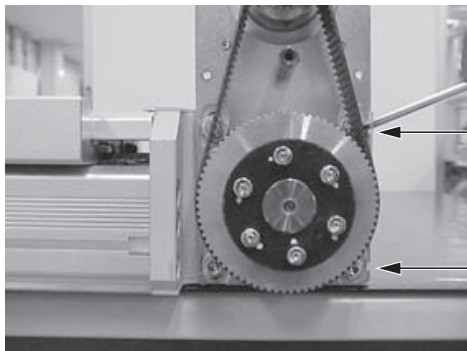

Use of Hexagon Wrench with the Distance to the Opposite Side of 3 mm

Use of Hexagon Wrench with the Distance to the Opposite Side of 4 mm

- Turn the motor shaft at an angle of 90 degrees from the counter mark to the returning direction to the mechanism end (direction confirmed at first).

Example:
In the case of X-SEL controller, turn it at an angle of 90 degrees to the returning direction to the mechanism end.
(Example in the case of turning right)

First Counter Mark Position

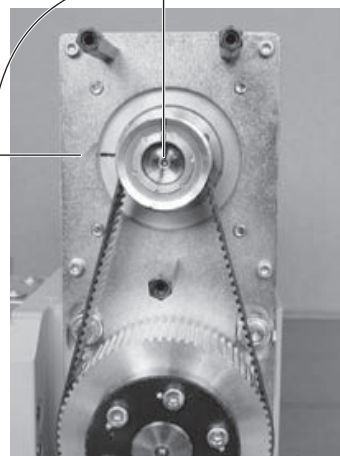

Controller	Returning Amount from the Counter Mark
X-SEL	90°
E-Con	
P-Driver	
SEL-E/G	45°
SEL-ES/GS,F,H	102°

- Go the ring-shaped strong thread (or long harness belt) around the motor cover and pull it using the tension gauge.
- Pull it with the specified tension and tighten the bolt (At that time, take care so that the slider or motor shaft does not move).

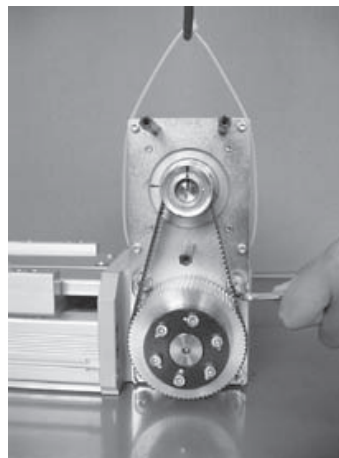
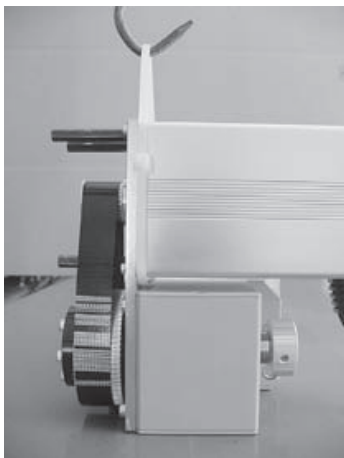

Tension: 5 kgf for IF-S and 10 kgf for IF-M



- 9) Attach the pulley cover.
- 10) Turn on the power to the controller and perform the homing operation from the personal computer or teaching pendant.
(In the case that the absolute encoder has been mounted, the absolute reset is required).
Confirm the deviation from the original home position.
If there is any deviation, adjust it using the home offset value in the parameters.

5.9 Deceleration Belt Replacement

[Items Required for Replacement Work]

- Replacement Deceleration Belt
- Hexagon Wrench Set
- Personal Computer or Teaching Pendant
- Tension Gauge (Tension of 10 kgf or more available)
- Ring-shaped Strong Thread (or Long Harness Belt)

[Replacement Operation Outline]

- 1) Loosen the bolt fixing the motor bracket and replace the belt.
- 2) Perform the homing operation.
Move the slider to the mechanism end and fix it. At the same time, fix the motor shaft at the position about 90 degrees deviated from the counter mark and adjust the deceleration belt to reach the specified tension value.
- 3) Perform the homing operation using the personal computer or teaching pendant and confirm the deviation from the original home position. If there is any deviation, adjust it using the home offset value in the parameters.
(Note) For the home offset for E/G controller, any negative value can not be entered. Therefore, deviate the position slightly less than 45 degrees.

[Procedure]

- 1) Confirm the motor shaft rotating direction when the slider is moved from the home position to the mechanism end.
(The rotating direction varies depending on the motor installation position. Therefore, the confirmation is always required).

- Remove the pulley cover.
(Use a hexagon wrench with the distance to the opposite side of 1.5 mm for IF-S or 2 mm for IF-M).



- Confirm the motor shaft rotating direction.

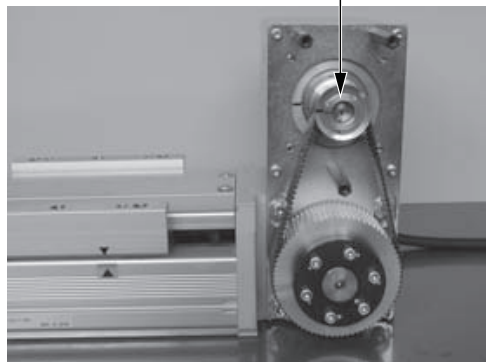

- 2) Loosen the deceleration belt.
Loosen the bolt fixing the motor bracket using the hexagon wrenches with the distance to the opposite side of 3 mm and 4 mm. Then, slide the belt until the pulley is turned without making any contact.

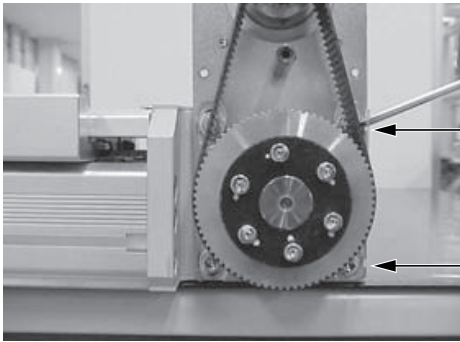

Use of Hexagon Wrench with the Distance to the Opposite Side of 3 mm

Use of Hexagon Wrench with the Distance to the Opposite Side of 4 mm

- 3) Remove the deceleration belt.

• Remove the deceleration belt manually.

• Condition where the deceleration belt has been removed

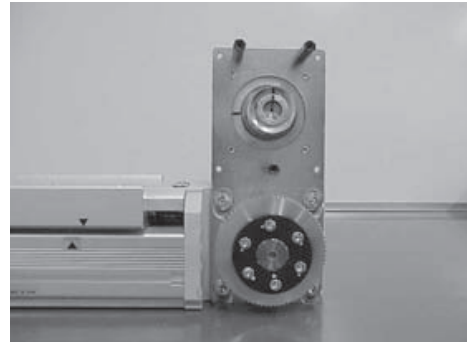

- 4) Attach the new deceleration belt manually.

5) Adjust it to recover the home position.

- Turn the motor shaft at an angle of 90 degrees from the counter mark to the returning direction to the mechanism end (direction confirmed at first).

Example:
In the case of X-SEL controller, turn it at an angle of 90 degrees to the returning direction to the mechanism end.
(Example in the case of turning right)

First Counter Mark Position

Controller	Returning Amount from the Counter Mark
X-SEL E-Con P-Driver	90°
SEL-E/F	45°
SEL-ES/GS,F,H	102°

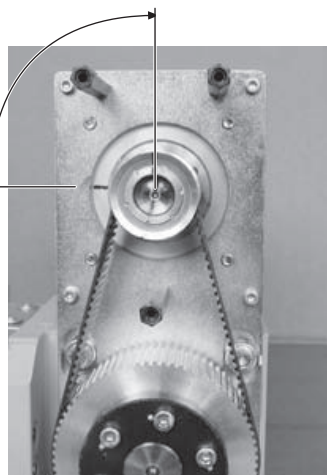

6) Adjust the belt tension.

- Go the ring-shaped strong thread (or long harness belt) around the motor cover and pull it using the tension gauge.
- Pull it with the specified tension and tighten the bolt. (At that time, take care so that the slider or motor shaft does not move).

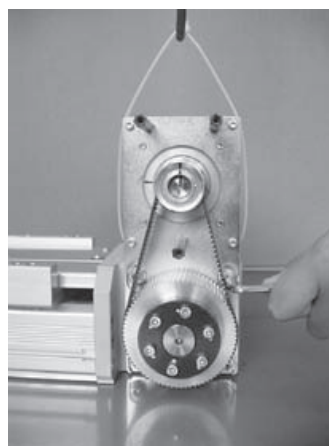
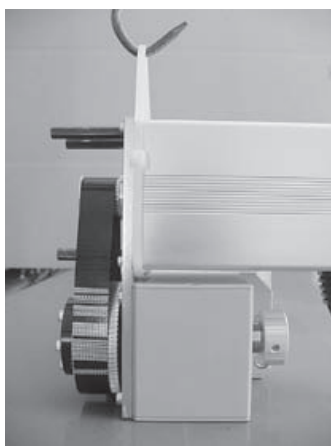

Tension: 5 kgf for IF-S and 10 kgf for IF-M

7) Attach the pulley cover.

- 8) Turn on the power to the controller and perform the homing operation from the personal computer or teaching pendant.
(In the case that the absolute encoder has been mounted, the absolute reset is required).
Confirm the deviation from the original home position. If there is any deviation, adjust it using the home offset value in the parameters.

5.10 Motor Replacement Process

[Items Required for Replacement Work]

- Motor for Replacemen (Refer to the right picture).
(Confirm that the counter mark is attached).
- Personal Computer or Teaching Pendant
- Tension Gauge (Tension of 10 kgf or more available)
- Strong Thread (or Long Harness Belt)
- Hexagon Wrench Set
- 5.5 mm Spanner Wrench and
Phillips Type Screwdriver

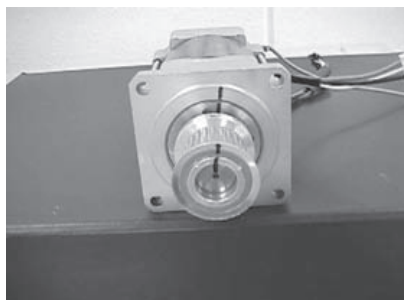

[Replacement Operation Outline]

- 1) Remove the deceleration belt and replace the motor.
- 2) Perform the homing operation.
Press the slider against the mechanism end on the home position side and fix it. Then, fix the motor shaft at the position deviated the specified amount from the counter mark position.
- 3) Attach the deceleration belt and tighten the motor bracket set bolt so that the specified tension value is reached.
- 4) Perform the homing operation using the personal computer or teaching pendant and confirm the deviation from the original home position.

If there is any deviation, adjust it using the home offset value in the parameters.

(Note) For the home offset for E/G controller, any negative value can not be entered. Therefore, deviate the position slightly less than 45 degrees.

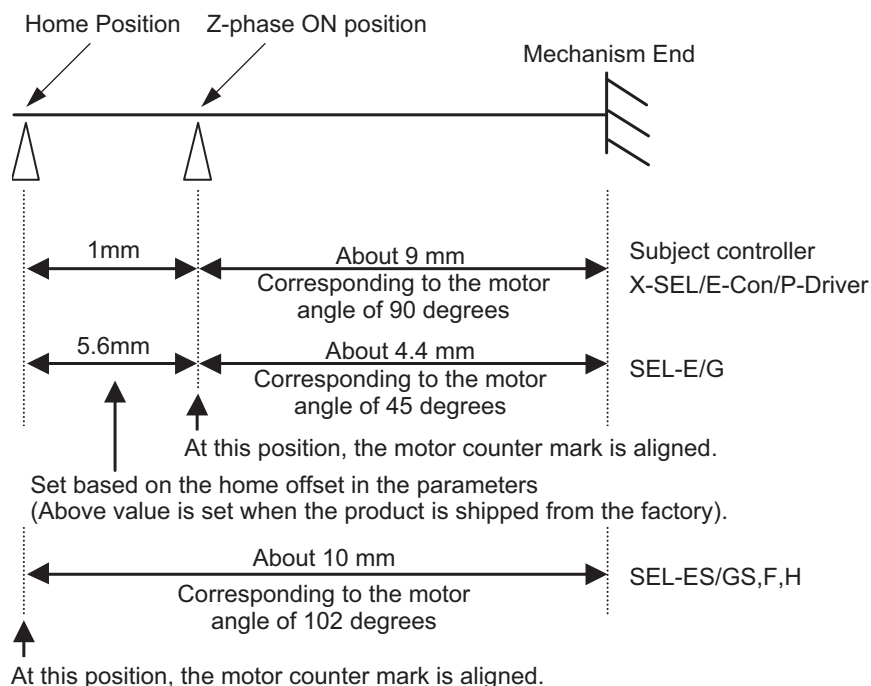

[Procedure]

- 1) Confirm the motor shaft rotating direction when the slider is moved from the home position to the mechanism end.
(The rotating direction varies depending on the motor installation position. Therefore, the confirmation is always required).

- Remove the pulley cover.
(Use a hexagon wrench with the distance to the opposite side of 1.5 mm for IF-S or 2 mm for IF-M).

- Confirm the motor shaft rotating direction.

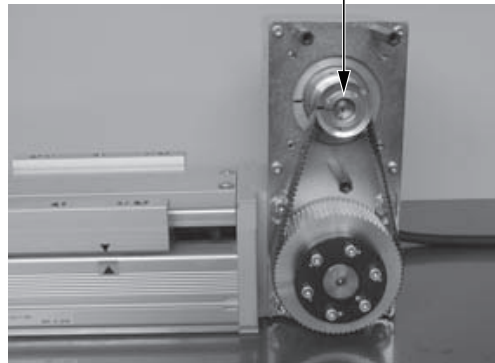

- 2) Remove the cable protection cover and disconnect the motor connector, encoder connector and motor earth cable.

- Protection Cover Removal
(Use a hexagon wrench with the distance to the opposite side of 1.5 mm)

- Because the earth cable is tightened with the M3 bolt, the 5.5 mm spanner wrench and Phillips type screwdriver are used.

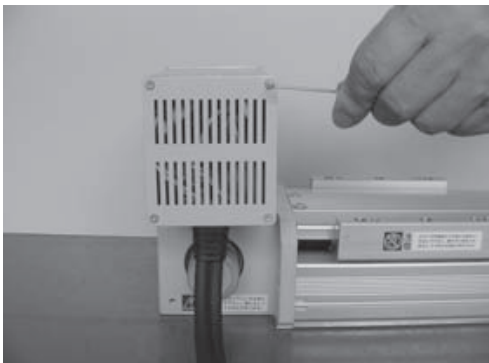

- 3) Remove the motor cover.
(Use a hexagon wrench with the distance to the opposite side of 2.5 mm)

- 4) Slightly loosen the bolt fixing the motor.
(Use a hexagon wrench with the distance to the opposite side of 3 mm for IF-S or 4 mm for IF-M).

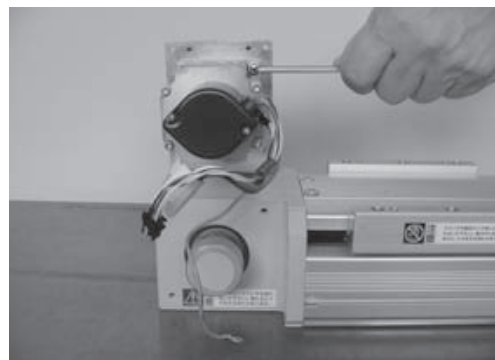
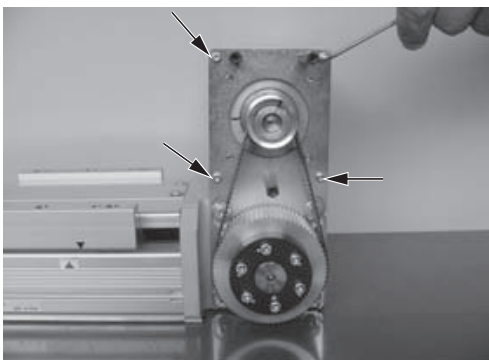

- 5) Loosen the bolt fixing the motor bracket using the hexagon wrenches with the distance to the opposite side of 3 mm and 4 mm). Then, slide the belt. Then, the deceleration belt tension is loosened. Remove the deceleration belt from the pulley on the actuator side.

- Loosen the motor bracket set bolt.

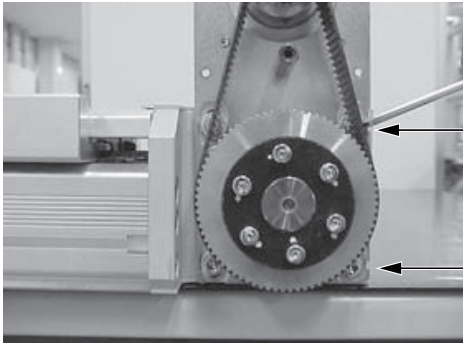

Use of Hexagon Wrench with the Distance to the Opposite Side of 3 mm

Use of Hexagon Wrench with the Distance to the Opposite Side of 4 mm



- Remove the deceleration belt manually.



- Condition where the deceleration belt has been removed

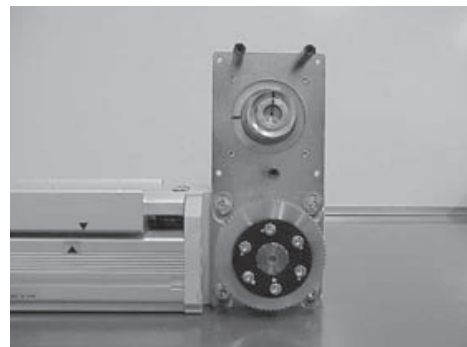

- 6) Remove the motor.

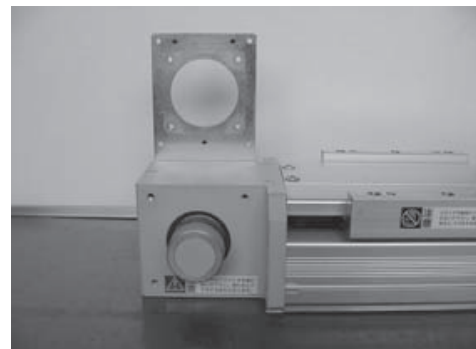
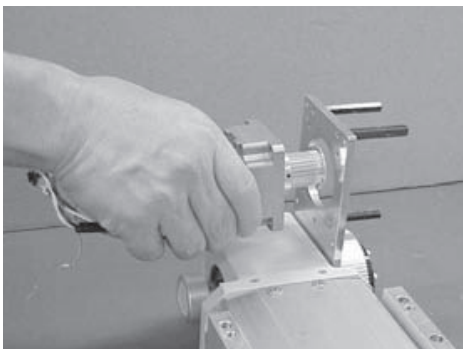

- 7) Attach the new motor.
Then, turn the motor shaft specified amount to the returning direction to the mechanism end (direction confirmed at the beginning) from the counter mark.

Example:
In the case of X-SEL controller, turn it at an angle of 90 degrees to the returning direction to the mechanism end.
(Example in the case of turning right)

First Counter Mark Position

Controller	Returning Amount from the Counter Mark
X-SEL	90°
E-Con	
P-Driver	
SEL-E/G	45°
SEL-ES/GS,F,H	102°

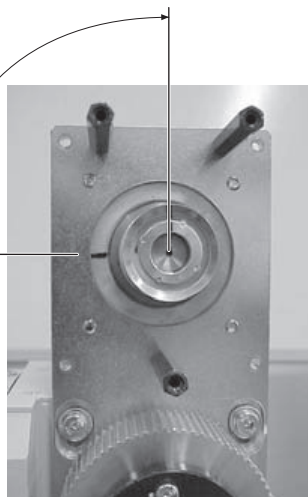

- 8) Attach the deceleration belt.
Press the slider against the mechanism end and fix it. Then, taking care so that the motor shaft does not move (refer to the above picture), put the belt on the pulley on the motor side, and then on the opposite side.
When it is difficult to put the belt, loosen the motor set bolt.
In this case, after the belt is attached, make sure to tighten the motor set bolt securely.
- 9) Pull the deceleration belt with the specified tension and tighten the motor bracket set bolt.

- Go the ring-shaped strong thread (or long harness belt) around the motor cover and pull it using the tension gauge.
- Pull it with the specified tension and tighten the bolt. (At that time, take care so that the slider or motor shaft does not move).

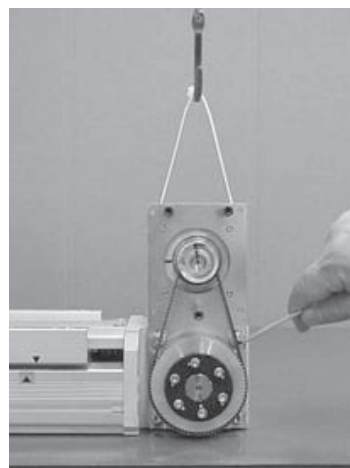
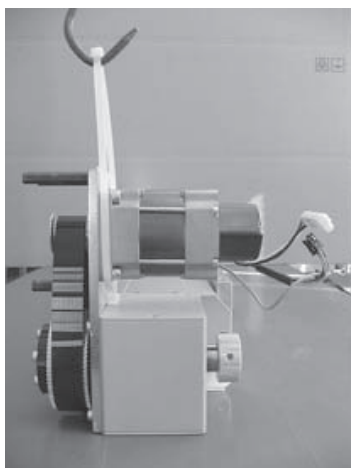

Tension: 5 kgf for IF-S and 10 kgf for IF-M

6. External Dimensions

6.1 IF-SA-60

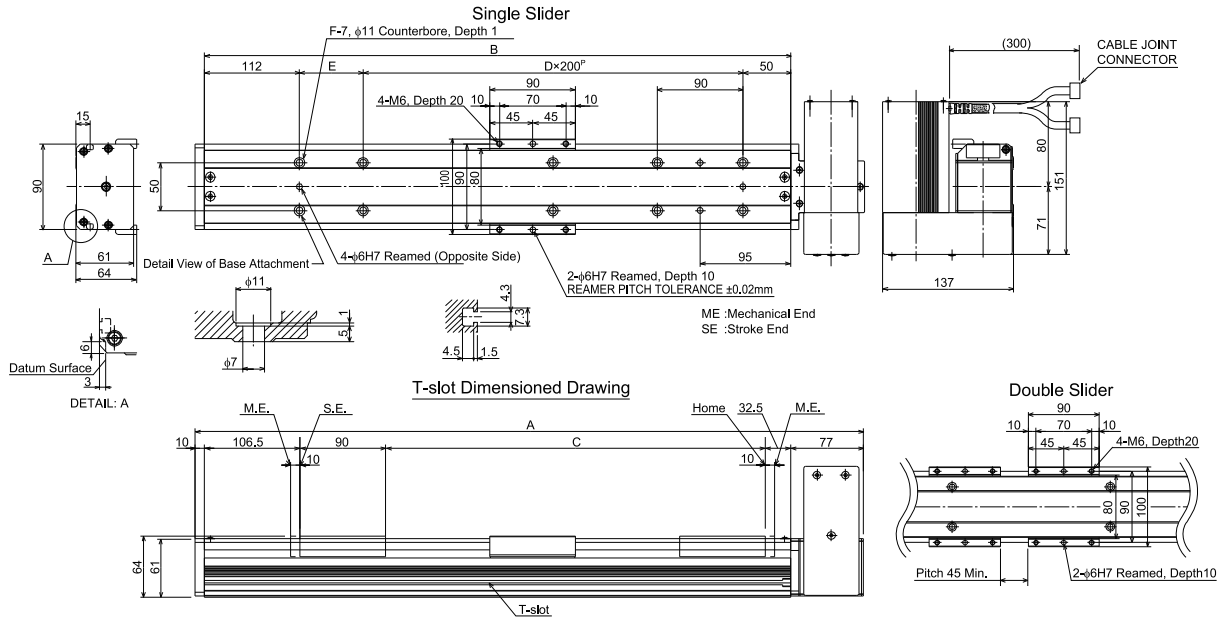

Stroke	200	300	400	500	600	700	800	900	1000	1100	1200	1300	1400	1500	1600	1700	1800	1900	2000
A	516	616	716	816	916	1016	1116	1216	1316	1416	1516	1616	1716	1816	1916	2016	2116	2216	2316
B	429	529	629	729	829	929	1029	1129	1229	1329	1429	1529	1629	1729	1829	1929	2029	2129	2229
C	200	300	400	500	600	700	800	900	1000	1100	1200	1300	1400	1500	1600	1700	1800	1900	2000
D	1	1	2	2	3	3	4	4	5	5	6	6	7	7	8	8	9	9	10
E	67	167	67	167	67	167	67	167	67	167	67	167	67	167	67	167	67	167	67
F	8	8	10	10	12	12	14	14	16	16	18	18	20	20	22	22	24	24	26
Weight [kg]	4.4	4.9	5.4	5.9	6.4	6.8	7.3	7.8	8.3	8.8	9.2	9.7	10.2	10.7	11.2	11.6	12.1	12.6	13.1

6.2 IF-SA-100

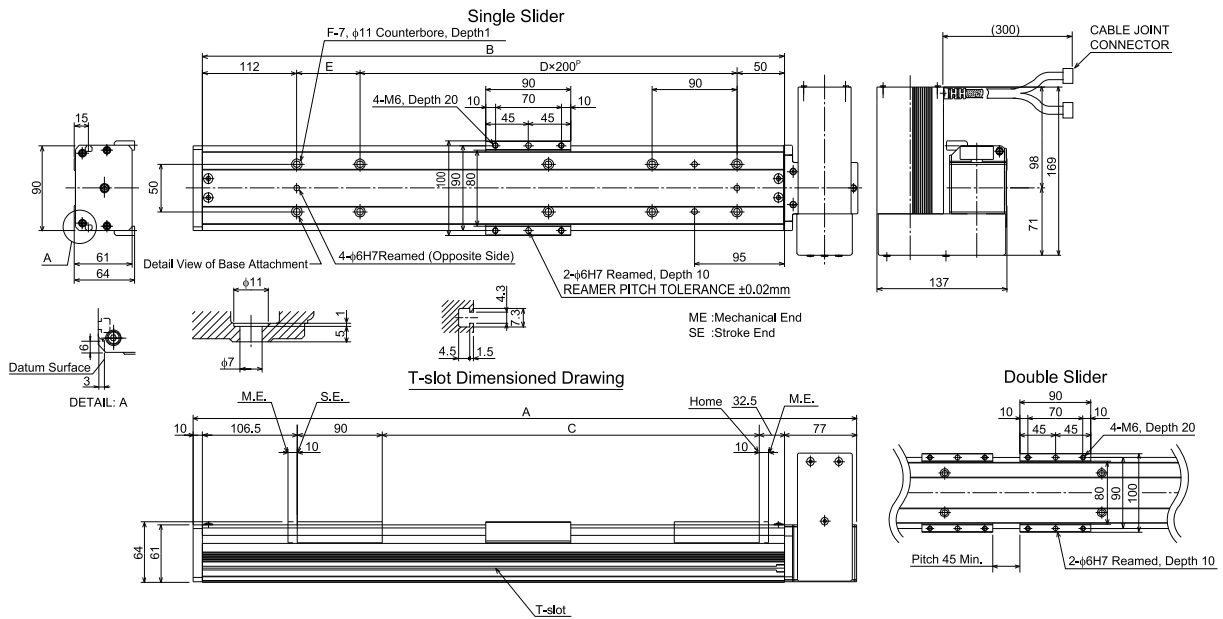

Stroke	200	300	400	500	600	700	800	900	1000	1100	1200	1300	1400	1500	1600	1700	1800	1900	2000
A	516	616	716	816	916	1016	1116	1216	1316	1416	1516	1616	1716	1816	1916	2016	2116	2216	2316
B	429	529	629	729	829	929	1029	1129	1229	1329	1429	1529	1629	1729	1829	1929	2029	2129	2229
C	200	300	400	500	600	700	800	900	1000	1100	1200	1300	1400	1500	1600	1700	1800	1900	2000
D	1	1	2	2	3	3	4	4	5	5	6	6	7	7	8	8	9	9	10
E	67	167	67	167	67	167	67	167	67	167	67	167	67	167	67	167	67	167	67
F	8	8	10	10	12	12	14	14	16	16	18	18	20	20	22	22	24	24	26
Weight [kg]	4.6	5.1	5.6	6.1	6.6	7.0	7.5	8.0	8.5	9.0	9.4	9.9	10.4	10.9	11.4	11.8	12.3	12.8	13.3

6.3 IF-MA-200

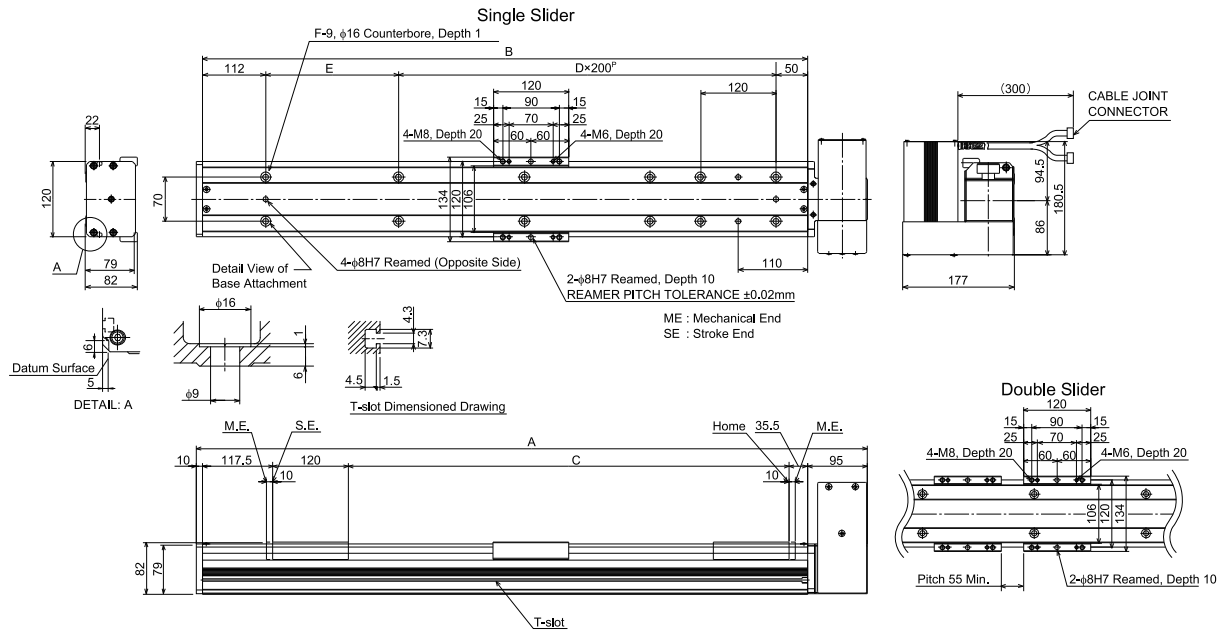

Stroke	200	300	400	500	600	700	800	900	1000	1100	1200	1300	1400	1500	1600	1700	1800	1900	2000	2100	2200	2300	2400	2500
A	578	678	778	878	978	1078	1178	1278	1378	1478	1578	1678	1778	1878	1978	2078	2178	2278	2378	2478	2578	2678	2778	2878
B	473	573	673	773	873	973	1073	1173	1273	1373	1473	1573	1673	1773	1873	1973	2073	2173	2273	2373	2473	2573	2673	2773
C	200	300	400	500	600	700	800	900	1000	1100	1200	1300	1400	1500	1600	1700	1800	1900	2000	2100	2200	2300	2400	2500
D	1	1	2	2	3	3	4	4	5	5	6	6	7	7	8	8	9	9	10	10	11	11	12	12
E	111	211	111	211	111	211	111	211	111	211	111	211	111	211	111	211	111	211	111	211	111	211	111	211
F	8	8	10	10	12	12	14	14	16	16	18	18	20	20	22	22	24	24	26	26	28	28	30	30
Weight [kg]	7.7	8.5	9.3	10.0	10.8	11.6	12.4	13.2	14.0	14.8	15.6	16.4	17.2	17.9	18.7	19.5	20.3	21.1	21.9	22.7	23.5	24.3	25.1	25.8

6.4 IF-MA-400

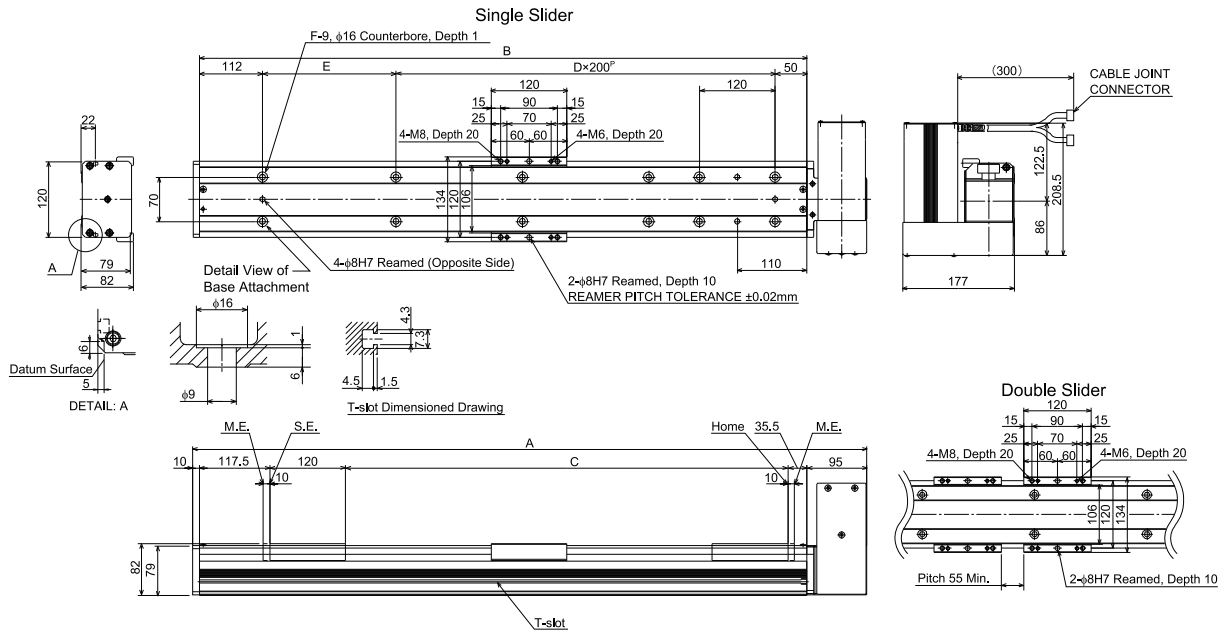

Stroke	200	300	400	500	600	700	800	900	1000	1100	1200	1300	1400	1500	1600	1700	1800	1900	2000	2100	2200	2300	2400	2500
A	578	678	778	878	978	1078	1178	1278	1378	1478	1578	1678	1778	1878	1978	2078	2178	2278	2378	2478	2578	2678	2778	2878
B	473	573	673	773	873	973	1073	1173	1273	1373	1473	1573	1673	1773	1873	1973	2073	2173	2273	2373	2473	2573	2673	2773
C	200	300	400	500	600	700	800	900	1000	1100	1200	1300	1400	1500	1600	1700	1800	1900	2000	2100	2200	2300	2400	2500
D	1	1	2	2	3	3	4	4	5	5	6	6	7	7	8	8	9	9	10	10	11	11	12	12
E	111	211	111	211	111	211	111	211	111	211	111	211	111	211	111	211	111	211	111	211	111	211	111	211
F	8	8	10	10	12	12	14	14	16	16	18	18	20	20	22	22	24	24	26	26	28	28	30	30
Weight [kg]	8.2	9.0	9.8	10.5	11.3	12.1	12.9	13.7	14.5	15.3	16.1	16.9	17.7	18.4	19.2	20.0	20.8	21.6	22.4	23.2	24.0	24.8	25.6	26.3



7. Life

The product life is 10,000km (reference) when operating the actuator with the maximum allowable load moment.



8. Warranty

8.1 Warranty Period

One of the following periods, whichever is shorter:

- 18 months after shipment from our factory
- 12 months after delivery to a specified location
- 2,500 operational hours

8.2 Scope of the Warranty

Our products are covered by warranty when all of the following conditions are met. Faulty products covered by warranty will be replaced or repaired free of charge:

- (1) The breakdown or problem in question pertains to our product as delivered by us or our authorized dealer.
- (2) The breakdown or problem in question occurred during the warranty period.
- (3) The breakdown or problem in question occurred while the product was in use for an appropriate purpose under the conditions and environment of use specified in the instruction manual and catalog.
- (4) The breakdown of problem in question was caused by a specification defect or problem, or by a quality issue with our product.

Note that breakdowns due to any of the following reasons are excluded from the scope of warranty:

- 1) Anything other than our product
- 2) Modification or repair performed by a party other than us (unless we have approved such modification or repair)
- 3) Anything that could not be easily predicted with the level of science and technology available at the time of shipment from our company
- 4) A natural disaster, man-made disaster, incident or accident for which we are not liable
- 5) Natural fading of paint or other symptoms of aging
- 6) Wear, depletion or other expected result of use
- 7) Operation noise, vibration or other subjective sensation not affecting function or maintenance

Note that the warranty only covers our product as delivered and that any secondary loss arising from a breakdown of our product is excluded from the scope of warranty.

8.3 Honoring the Warranty

As a rule, the product must be brought to us for repair under warranty.

8.4 Limit in Responsibility

- (1) We shall assume no liability for any special damage, consequential loss or passive loss such as a loss of expected profit arising from or in connection with our product.
- (2) We shall not be liable for any program or control method created by the customer to operate our product or for the result of such program or control method.

8.5 Conditions of Conformance with Applicable Standards/Regulations, Etc., and Applications

- (1) If our product is combined with another product or any system, device, etc., used by the customer, the customer must first check the applicable standards, regulations and/or rules. The customer is also responsible for confirming that such combination with our product conforms to the applicable standards, etc. In such a case we will not be liable for the conformance of our product with the applicable standards, etc.
- (2) Our product is for general industrial use. It is not intended or designed for the applications specified below, which require a high level of safety. Accordingly, as a rule our product cannot be used in these applications. Contact us if you must use our product for any of these applications:
 - 1) Medical equipment used to maintain, control or otherwise affect human life or physical health
 - 2) Mechanisms and machinery designed for the purpose of moving or transporting people (For vehicle, railway facility or air navigation facility)
 - 3) Important safety parts of machinery (Safety device, etc.)
 - 4) Equipment used to handle cultural assets, art or other irreplaceable items
- (3) Contact us at the earliest opportunity if our product is to be used in any condition or environment that differs from what is specified in the catalog or instruction manual.

8.6 Other Items Excluded from Warranty

The price of the product does not include the cost to create programs or sending an engineer. Accordingly, a separate fee will be charged in the following cases even during the warranty period:

- 1) Instruction for adjustment in installation or joining to the test run of product operation.
- 2) Maintenance inspection
- 3) Technical instruction or education for operation or cable layout
- 4) Technical instruction or education related to programming such as creating a program

Change History

Revision Date	Description of Revision
2012.01	Ninth Edition Page 7 Note of available and not available added to attachment orientation
2012.07	Tenth Edition Whole manual layout has been revised and corrected
2012.12	Eleventh Edition Page 46 $\delta = 0.0032L \rightarrow \delta = 0.032L$
2015.04	Twelfth Edition Page 12, 13 Touch Panel Teaching Pendant TB-01 added Page 12, 13, 14, 18, 23, 35, 36 Dedicated controller added Page 14, 17, 36 Metal connector type added Page 32 Dynamic allowable moment value changed
2015.06	Edition 12B Page 43 <ul style="list-style-type: none"> • Grease change due to production stop Albania grease No.2 \rightarrow Albania grease S2 Mobilux 2 \rightarrow Unirex N2 • Grease supply volume, Recommended grease gun added



IAI Corporation

Head Office: 577-1 Obane Shimizu-KU Shizuoka City Shizuoka 424-0103, Japan
TEL +81-54-364-5105 FAX +81-54-364-2589
website: www.iai-robot.co.jp/

Technical Support available in USA, Europe and China

IAI America, Inc.

Head Office: 2690 W. 237th Street, Torrance, CA 90505
TEL (310) 891-6015 FAX (310) 891-0815
Chicago Office: 110 East State Parkway, Schaumburg, IL 60173
TEL(847) 908-1400 FAX (847) 908-1399
Atlanta Office: 1220 Kennestone Circle, Suite 108, Marietta, GA 30066
TEL (678) 354-9470 FAX (678) 354-9471
website: www.intelligentactuator.com

IAI Industrieroboter GmbH

Ober der Röth 4, D-65824 Schwalbach am Taunus, Germany
TEL 06196-88950 FAX 06196-889524

IAI (Shanghai) Co., Ltd.

SHANGHAI JIAHUA BUSINESS CENTER A8-303, 808, Hongqiao Rd. Shanghai 200030, China
TEL 021-6448-4753 FAX 021-6448-3992
website: www.iai-robot.com

IAI Robot (Thailand) Co., Ltd.

825, PhairojKijja Tower 12th Floor, Bangna-Trad RD., Bangna, Bangkok 10260, Thailand
TEL +66-2-361-4458 FAX +66-2-361-4456