

# ROBO Cylinder®

## Slider Type

RCS4-SA4C/SA6C/SA7C/SA8C

SA4R/SA6R/SA7R/SA8R

RCS4CR-SA4C/SA6C/SA7C/SA8C

Instruction Manual

First Edition

ME3769-1A



Specifications	ch. 1
Installation	ch. 2
Connecting with the Controller	ch. 3
Maintenance and Inspection	ch. 4
External Dimensions	ch. 5
Life	ch. 6
Warranty	ch. 7
Appendix	ch. 8



## **Please Read Before Use**

Thank you for purchasing our product.

This instruction manual explains the handling methods, structure and maintenance of this product, providing the information you need in order to use the product safely.

Before using the product, be sure to read this manual and fully understand the contents explained herein to ensure safe use of the product.

The DVD enclosed with the product contains instruction manuals for IAI products.

When using the product, refer to the necessary sections of the applicable instruction manual by printing them out or displaying them on a PC.

After reading the instruction manual, keep it in a convenient place so that whoever is handling the product can refer to it quickly when necessary.

### **[Important]**

- This instruction manual is an original document dedicated for this product.
- This product cannot be used in ways not shown in this instruction manual. IAI shall not be liable for any result whatsoever arising from the use of the product in any other way than what is noted in the manual.
- The information contained in this instruction manual is subject to change without notice for the purpose of product improvement.
- If any issues arise regarding the information contained in this instruction manual, contact our customer center or the nearest sales office.
- Use or reproduction of this instruction manual in full or in part without permission is prohibited.
- The company names, names of products and trademarks of each company shown in the text are registered trademarks.

## RCS4 Slider Type Instruction Manual Configuration

Product name	Instruction manual name	Control number
RCS4	First Step Guide	ME3775
RCS4 Slider Type	Instruction Manual (this document)	ME3769
SCON-CB/CFB Controller	SCON-CB/CFB Controller Instruction Manual	ME0340
SCON-CAL/CGAL Controller	SCON-CAL/CGAL Controller Instruction Manual	ME0243
MSCON-C Controller	MSCON-C Controller Instruction Manual	ME0306
SSEL-CS Controller	SSEL-CS Controller Instruction Manual	ME0157
XSEL-P/Q Controller	XSEL-P/Q Controller Instruction Manual	ME0148
XSEL-R/S Controller	XSEL-R/S Controller Instruction Manual	ME0313
XSEL-RA/SA Controller	XSEL-RA/SA Controller Instruction Manual	ME0359
PC Compatible Software for RC/EC	RCM-101-MW/RCM-101-USB Instruction Manual	ME0155
PC Compatible Software for XSEL	IA-101-X-MW/IA-101-X-USB Instruction Manual	ME0154
Touch Panel Teaching Pendant	TB-01/01D/01DR Applicable for Position Controller Instruction Manual	ME0324
Touch Panel Teaching Pendant	TB-02/02D Applicable for Position Controller Instruction Manual	ME0355
Data Setter	TB-03 Applicable for Position Controller	ME0376
Touch Panel Teaching Pendant	TB-01/01D/01DR Applicable for Program Controller Instruction Manual	ME0325
Touch Panel Teaching Pendant	TB-02/02D Applicable for Program Controller Instruction Manual	ME0356
Data Setter	TB-03 Applicable for Program Controller	ME0377

# Contents

Safety Guide	Intro-1
Precautions for Handling	Intro-9
International Standard Compliance	Intro-10
Names of the Parts	Intro-11

## Chapter 1 Specifications

1.1	Checking the product	1-1
	Parts	1-1
	How to Read the Model Nameplate	1-2
	How to Read the Model Number	1-2
	Product list	1-3
1.2	Specifications	1-4
	Specifications	1-4
	Double Slider (Option)	1-28
	Duty ratio	1-29
1.3	Options	1-31
	With brake (Model Code: B)	1-31
	Cable Exit Direction Changed (Model Code: CJT, CJR, CJL, CJB and CJO)	1-31
	High Precision Specifications (Model Code: HPR)	1-31
	Motor Reversed Direction (Model Code: ML, MR)	1-31
	Reversed-home Specification (Model Code: NM)	1-31
	Slider Roller Specification (Model Code: SR)	1-32
	Vacuum Joint Attachment Opposite Type (Model Code: VR)	1-32
	Double Slider Specification (Model Code: W)	1-32
	Rear Attachment Plate (Model Code: RP)	1-32
	Slider spacer (Model Code: SS)	1-33
1.4	Accessories	1-35
	Motor Cable	1-35
	Encoder Cable	1-36

## Chapter 2 Installation

2.1	Precautions for transportation	2-1
2.2	Installation and storage/preservation environment	2-3
	Installation Environment	2-3
	Storage/preservation environment	2-4
2.3	How to Install	2-5
	Installation Orientation	2-5
	Precautions regarding stainless steel sheet	2-6
	Installation surface	2-7
	Installation of the Main Unit	2-8
	Mounting transported objects	2-16
	About Suction of the Cleanroom Type	2-19

## Chapter 3 Connecting with the Controller

3.1	Connecting with the Controller	3-1
-----	--------------------------------	-----

## Chapter 4 Maintenance and Inspection

4.1	Precautions for maintenance and inspection work	4-1
4.2	Inspection Items and Schedule	4-3
	Slider type	4-3
	Grease supply timing (Guideline)	4-3
4.3	Visual inspection items	4-4
	External visual inspection	4-4
	Internal visual inspection	4-5
4.4	Cleaning	4-7
	External cleaning	4-7
	Internal Cleaning	4-7
4.5	Greasing method	4-8
	Grease used	4-8
	Greasing method	4-10
4.6	How to replace components	4-13
	Stainless steel sheet replacement/adjustment	4-13
	Belt replacement/adjustment	4-19
	Motor Replacement	4-24

## Chapter 5 External Dimensions

5.1	External Dimensions	5-1
	RCS4-SA4C	5-1
	RCS4-SA6C	5-2
	RCS4-SA7C	5-3
	RCS4-SA8C	5-4
	RCS4-SA4R	5-5
	RCS4-SA6R	5-7
	RCS4-SA7R	5-8
	RCS4-SA8R	5-10
	RCS4CR-SA4C	5-12
	RCS4CR-SA6C	5-13
	RCS4CR-SA7C	5-14
	RCS4CR-SA8C	5-15

## Chapter 6 Life

6.1	Concept of life for slider type	6-1
	How to calculate operation life	6-1
	Relation between operation life and moment	6-3

## Chapter 7 Warranty

7.1	Warranty period	7-1
7.2	Scope of the warranty	7-1
7.3	Honoring the warranty	7-1
7.4	Limited liability	7-2
7.5	Conformance with applicable standards/regulations, etc., and application conditions	7-2
7.6	Other Items excluded from warranty	7-2

## Chapter 8 Appendix

8.1	Index	8-1
8.2	Revision history	8-3

## **Safety Guide**

The Safety Guide is intended to permit safe use of the product and thus to prevent risks and property damage. Be sure to read it before handling the product.

## Safety Precautions for Our Products

Common safety precautions for the use of robots in various operations are indicated here.

No.	Operation	Precautions
1	Model Selection	<ul style="list-style-type: none"> <li>● This product is not intended or designed for applications where high levels of safety are required, and so cannot guarantee that human lives will be protected. Accordingly, do not use it in any of the following applications.                             <ol style="list-style-type: none"> <li>(1) Medical equipment used to maintain, control or otherwise affect human life or physical health</li> <li>(2) Mechanisms or machinery designed for the purpose of moving or transporting people (vehicles, railway facilities, aviation facilities etc.)</li> <li>(3) Machinery components essential for safety (safety devices etc.)</li> </ol> </li> <li>● Do not use the product outside the range of the specifications. Otherwise, the product life may be drastically shortened, and product damage or facilities stoppage may occur.</li> <li>● Do not use it in any of the following environments.                             <ol style="list-style-type: none"> <li>(1) Locations with flammable gases, ignitable objects or explosives</li> <li>(2) Locations with potential exposure to radiation</li> <li>(3) Locations with ambient temperature or relative humidity exceeding the specifications range</li> <li>(4) Locations where radiant heat is applied by direct sunlight or other large heat source</li> <li>(5) Locations where condensation occurs due to abrupt temperature changes</li> <li>(6) Locations with corrosive gases (sulfuric acid, hydrochloric acid, etc.)</li> <li>(7) Locations exposed to significant amounts of dust, salt or iron powder</li> <li>(8) Locations subject to direct vibration or impact</li> </ol> </li> <li>● For an actuator used in vertical orientation, select a model which is equipped with a brake. If a model without brake is selected, the moving parts may fall when the power is turned OFF, causing accidents such as injury or workpiece damage.</li> </ul>



No.	Operation	Precautions
2	Transportation	<ul style="list-style-type: none"> <li>● When transporting heavy objects, do the work with two or more persons or utilize equipment such as a crane.</li> <li>● When working with two or more persons, make it clear who is to be in charge and communicate well with each other to ensure safety.</li> <li>● During transportation, carefully consider the carrying positions, weight, and weight balance, and be careful to avoid collisions or dropping.</li> <li>● Use appropriate transportation measures for transport. The actuators available for transportation with a crane have eyebolts attached or tapped holes to attach bolts. Follow the instructions in the instruction manual for each model.</li> <li>● Do not climb onto the package.</li> <li>● Do not put anything heavy that could deform the package on it.</li> <li>● When using a crane with capacity of 1t or more, have an operator qualified for crane operation and sling work.</li> <li>● When using a crane or equivalent equipment, make sure not to suspend loads exceeding the equipment's rated load.</li> <li>● Use a hook that is suitable for the load. Consider the safety factor of the hook in such factors as shear strength. Also, check to make sure that the hook is free of damage.</li> <li>● Do not climb on loads suspended from cranes.</li> <li>● Do not leave loads suspended from cranes for long periods.</li> <li>● Do not stand under loads suspended from cranes.</li> </ul>
3	Storage and Preservation	<ul style="list-style-type: none"> <li>● For the storage and preservation environment, see the installation environment. However, give especial consideration to the prevention of condensation.</li> <li>● Store the products so as to prevent them from falling over or down in the case of natural disasters such as earthquakes.</li> </ul>

No.	Operation	Precautions
4	Installation and Startup	<p>(1) Installation of robot body and controller, etc.</p> <ul style="list-style-type: none"> <li>● Be sure to securely hold and fix the product (including the workpiece). If the product falls over, is dropped, or operates abnormally, it may lead to damage and injury. Also, be equipped for falls over or down due to natural disasters such as earthquakes.</li> <li>● Do not climb on or put anything on the product. Otherwise, this may lead to accidental falling, injury or damage to the product due to falling objects, product loss of function or performance degradation, or shortening of product life.</li> <li>● When using the product in any of the places specified below, provide sufficient shielding.               <ol style="list-style-type: none"> <li>(1) Locations where electrical noise is generated</li> <li>(2) Locations with strong electrical or magnetic fields</li> <li>(3) Locations with mains or power lines passing nearby</li> <li>(4) Locations where the product may come in contact with water, oil or chemical spray</li> </ol> </li> </ul> <p>(2) Cable wiring</p> <ul style="list-style-type: none"> <li>● Use IAI genuine cables for connecting the actuator and controller, and for the teaching tools.</li> <li>● Do not scratch cables, bend them forcibly, pull them, coil them, snag them, or place heavy objects on them. Otherwise, this may lead to fire, electric shock, or abnormal operation due to leakage or conduction malfunction.</li> <li>● Perform the wiring for the product after turning OFF the power to the unit, and avoid miswiring.</li> <li>● When wiring DC power (+24V), be careful with the positive/negative polarity. Incorrect connections may lead to fire, product breakdown or abnormal operation.</li> <li>● Connect the cable connector securely so that there is no disconnection or looseness. Otherwise, this may lead to fire, electric shock, or abnormal operation of the product.</li> <li>● Never cut or reconnect the cables supplied with the product for the purpose of extending or shortening the cable length. Otherwise, this may lead to fire or abnormal operation of the product.</li> </ul> <p>(3) Grounding</p> <ul style="list-style-type: none"> <li>● Grounding must be performed, in order to prevent electric shocks or electrostatic charge, enhance noise-resistant performance and control unnecessary electromagnetic radiation.</li> <li>● For the ground terminal on the AC power cable of the controller and the grounding plate in the control panel, be sure to use a twisted pair cable with wire thickness 0.5mm<sup>2</sup> (AWG20 or equivalent) or more for grounding work. For safeguard grounding, it is necessary to select an appropriate wire diameter for the load. Perform wiring that satisfies the specifications (electrical equipment technical standards).</li> <li>● Perform Class D grounding (former Class 3 grounding, with ground resistance 100Ω or below).</li> </ul>





No.	Operation	Precautions
4	Installation and Startup	<p>(4) Safety measures</p> <ul style="list-style-type: none"> <li>● When working with two or more persons, make it clear who is to be in charge and communicate well with each other to ensure safety.</li> <li>● When the product is operating or in the ready mode, take safety measures (such as the installation of safety/protection fences) so that nobody can enter the area within the robot's movable range. Contact with an operating robot may lead to death or serious injury.</li> <li>● Be sure to install an emergency stop circuit so that the unit can be stopped immediately in an emergency during operation.</li> <li>● Take safety measures such that turning the power ON alone will not start up the unit. Otherwise, this may cause the product to start unexpectedly, leading to injury or product damage.</li> <li>● Take safety measures such that emergency stop cancel or recovery after power failure alone will not start up the unit. Otherwise, this may lead to injury or equipment damage.</li> <li>● When installation or adjustment operation is to be performed, display signs such as "Operating: No Power ON!" etc. Sudden power input may cause electric shock or injury.</li> <li>● Take measures to prevent workpieces, etc. from falling during power failures or emergency stop.</li> <li>● Wear protection gloves, goggles and safety shoes, as necessary, to secure safety.</li> <li>● Do not insert fingers or objects into the openings in the product. Otherwise, this may lead to injury, electric shock, product damage, or fire.</li> <li>● When releasing the brake on a vertically oriented actuator, be careful that it does not fall under its own weight, catching the operator's hand or damaging workpieces.</li> </ul>
5	Teaching	<ul style="list-style-type: none"> <li>● When working with two or more persons, make it clear who is to be in charge and communicate well with each other to ensure safety.</li> <li>● Perform teaching operation from outside the safety/protection fence, if possible. If operation must be performed within the safety/protection fence, prepare "Work Regulations" and make sure that all the workers acknowledge and understand them well.</li> <li>● When operation is to be performed inside the safety/protection fence, operators should have emergency stop switches available at hand so that the unit can be stopped at any time if abnormalities occur.</li> <li>● When operation is to be performed inside the safety/protection fence, have a monitor standing by in addition to the operator(s) so that the unit can be stopped at any time if abnormalities occur. Also, keep watch on the operation so that a third party cannot operate the switches carelessly.</li> <li>● Place a sign indicating "Operating" where it can be seen easily.</li> <li>● When releasing the brake on a vertically oriented actuator, be careful that it does not fall under its own weight, catching the operator's hand or damaging workpieces.</li> </ul> <p>* Safety/protection fence: If there is no safety/protection fence, the movable range should be indicated.</p>

No.	Operation	Precautions
6	Trial Operation	<ul style="list-style-type: none"> <li>● When working with two or more persons, make it clear who is to be in charge and communicate well with each other to ensure safety.</li> <li>● After teaching or programming, carry out trial operation step by step before switching to automatic operation.</li> <li>● When trial operation is to be performed inside the safety/protection fence, use the same work procedure, determined in advance, as teaching operation.</li> <li>● Be sure to confirm program operation at safe speeds. Otherwise, this may lead to accidents due to unexpected motion caused by program error, etc.</li> <li>● Do not touch the terminal block or any of the various setting switches while the equipment is live. Otherwise, this may lead to electric shock or abnormal operation.</li> </ul>
7	Automatic Operation	<ul style="list-style-type: none"> <li>● Check before starting automatic operation or restarting after operation stop that there is nobody within the safety/protection fence.</li> <li>● Before starting automatic operation, make sure that all peripheral equipment is ready for automatic operation and that there is no alarm indication.</li> <li>● Be sure to start automatic operation from outside the safety/protection fence.</li> <li>● If the product produces abnormal heat, smoke, odor, or noise, immediately stop it and turn OFF the power switch. Otherwise, this may lead to fire or damage to the product.</li> <li>● When a power failure occurs, turn OFF the power switch. Otherwise, this may lead to injury or product damage due to unexpected product motion during recovery from the power failure.</li> </ul>
8	Maintenance and Inspection	<ul style="list-style-type: none"> <li>● When working with two or more persons, make it clear who is to be in charge and communicate well with each other to ensure safety.</li> <li>● Perform the work outside the safety/protection fence, if possible. If operation must be performed within the safety/protection fence, prepare "Work Regulations" and make sure that all the workers acknowledge and understand them well.</li> <li>● When work is to be performed inside the safety/protection fence, turn OFF the power switch as a rule.</li> <li>● When operation is to be performed inside the safety/protection fence, operators should have emergency stop switches available at hand so that the unit can be stopped at any time if abnormalities occur.</li> <li>● When operation is to be performed inside the safety/protection fence, have a monitor standing by in addition to the operator(s) so that the unit can be stopped at any time if abnormalities occur. Also, keep watch on the operation so that a third party cannot operate the switches carelessly.</li> <li>● Place a sign indicating "Operating" where it can be seen easily.</li> <li>● For the grease for the guide or ball screw, use appropriate grease according to the Instruction Manual for each model.</li> <li>● Do not perform dielectric strength testing. Otherwise, this may lead to damage to the product.</li> </ul>

No.	Operation	Precautions
8	Maintenance and Inspection	<ul style="list-style-type: none"> <li>● When releasing the brake on a vertically oriented actuator, be careful that it does not fall under its own weight, catching the operator's hand or damaging workpieces.</li> <li>● The slider or rod may be misaligned from the stop position if the servo is turned OFF. Avoid injury or damage due to unnecessary operation.</li> <li>● Be careful not to lose the cover or any removed screws, and be sure to return the product to the original condition after maintenance and inspection work. Otherwise, this may lead to product damage or injury due to incomplete mounting.</li> </ul> <p>* Safety/protection fence: If there is no safety/protection fence, the movable range should be indicated.</p>
9	Modification and Disassembly	<ul style="list-style-type: none"> <li>● Do not modify, disassemble/assemble, or use maintenance parts not specified on your own discretion.</li> </ul>
10	Disposal	<ul style="list-style-type: none"> <li>● When the product exceeds its useful life or is no longer needed, dispose of it properly as industrial waste.</li> <li>● When removing the actuator for disposal, avoid dropping components when detaching screws.</li> <li>● Do not put the product in a fire when disposing of it. The product may rupture or generate toxic gases.</li> </ul>
11	Other	<ul style="list-style-type: none"> <li>● If you are equipped with a medical device such as a pacemaker, do not approach the product or its wiring, as the device may be affected.</li> <li>● See the Overseas Specifications Compliance Manual to check compliance with overseas standards if necessary.</li> <li>● For the handling of actuators and controllers, follow the dedicated instruction manual of each unit to ensure safety.</li> </ul>

## Precaution Indications

The safety precautions are divided into "Danger", "Warning", "Caution" and "Notice" according to the warning level, as follows, and described in the Instruction Manual for each model.

Level	Degree of risk to persons and property	Symbol
Danger	This indicates an imminently hazardous situation which, if the product is not handled correctly, will result in death or serious injury.	 <b>Danger</b>
Warning	This indicates a potentially hazardous situation which, if the product is not handled correctly, could result in death or serious injury.	 <b>Warning</b>
Caution	This indicates a potentially hazardous situation which, if the product is not handled correctly, may result in minor injury or property damage.	 <b>Caution</b>
Notice	This indicates a situation in which, while injury is not a likely result, the precautions should be observed in order to use the product appropriately.	 <b>Notice</b>

## Precautions for Handling

1. The Safety Guide attached with the product is intended to permit safe use of the product and thus to prevent risks and property damage. Be sure to read it before handling the product.
2. Do not attempt any handling or operation that is not indicated in this instruction manual.
3. Make sure to secure the actuator properly in accordance with this instruction manual.

If the actuator is not securely fixed, this may lead to abnormal noise, vibration, breakdown or shortened product life.

4. Make sure to observe the usage conditions and environment of the product.

Operation outside the warranty could cause decreased performance or product breakdown.

Use within the allowable range for each item.

Item	Cautions for use	Problems or breakdowns which may occur if the allowable range is exceeded
Speed and acceleration/deceleration	Use within the allowable range	May lead to abnormal noise, vibration, breakdown, or shortened product life.
Allowable load moment	Use within the allowable range	May lead to abnormal noise, vibration, breakdown, or shortened product life. In extreme cases, flaking may occur on the guide or ball screw.
Overhang load length		Mounting a load with an overhang length greater than the allowable values may lead to vibration or abnormal noise.

5. If return operations are continued over a short distance, they may rapidly degrade the film of grease.

Continuous return operation within a distance less than 30mm may cause the grease film to degrade rapidly.

As a guideline, in every 5,000 to 10,000 cycles, have approximately 5 cycles of return operation over a 50mm distance or more to regenerate the oil film. Continued use of the actuator in that state may lead to breakdown.

In extreme cases, flaking may occur on the guide or ball screw.

6. Do not attempt to have sliders collide with an obstacle at high speed.

This may damage the coupling or other mechanical parts.

7. For Double Slider Specification (Option Code: W) in Reversed-home Specification (Option Code: NM), make sure to have the home-return operation conducted after joining the driver slider and free slider.

8. In some conditions of environment of use, postures of installation and conditions of operation, the base oil separated from the grease may come out of ROBO Cylinder.

It is recommended to have a protection in case the peripheral devices could get influence of the base oil.

## International Standard Compliance

The ROBO Cylinder complies with the following overseas standards.

Refer to the Overseas Standard Compliance Manual (ME0287) for more detailed information.

CE Marking	RoHS Directive
○	○



## Names of the Parts

In this manual, the actuator left/right sides and motor/opposite sides are shown as in the figure below.

### Standard Type Motor Straight Type

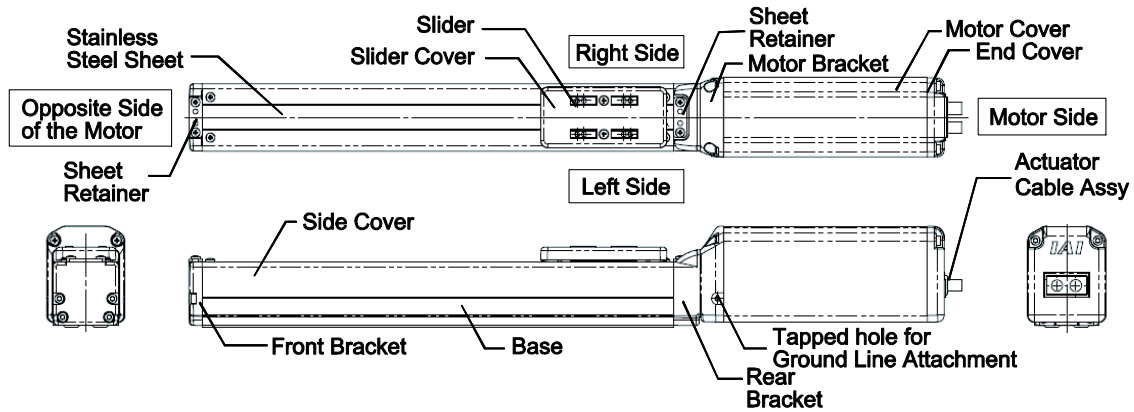

### Standard Type Motor Reversing Type

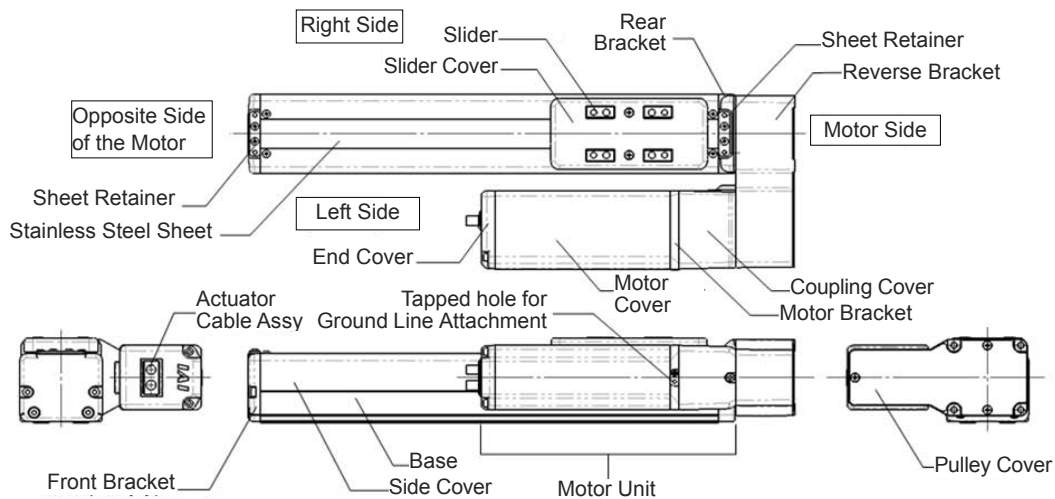

## Cleanroom Type Motor Straight Type

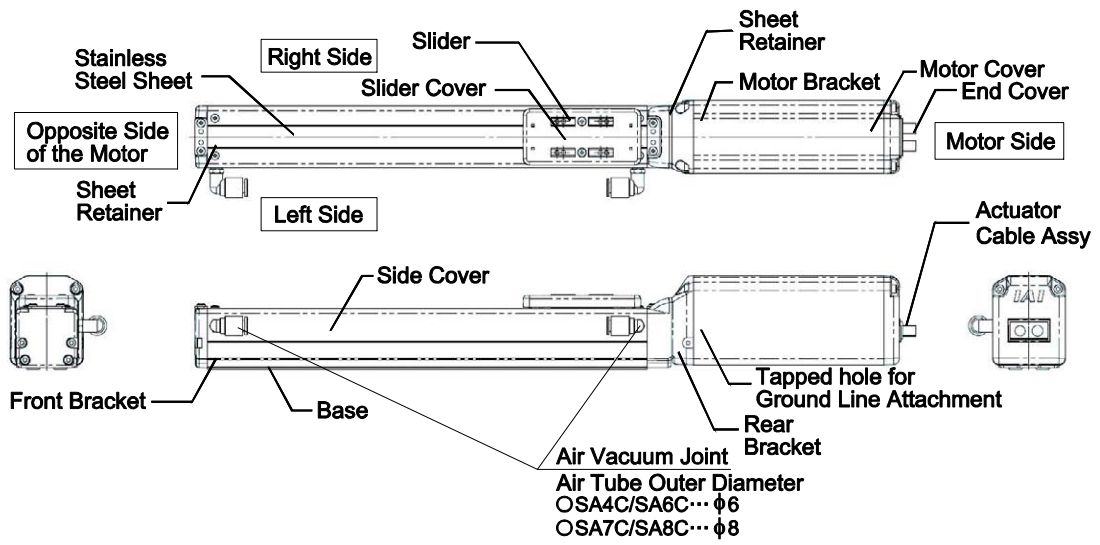

# ROBO Cylinder

## Chapter 1







# Specifications

1.1	Checking the product	1-1
	Parts	1-1
	How to Read the Model Nameplate	1-2
	How to Read the Model Number	1-2
	Product list	1-3
1.2	Specifications	1-4
	Specifications	1-4
	Double Slider (Option)	1-28
	Duty ratio	1-29
1.3	Options	1-31
	With brake (Model Code: B)	1-31
	Cable Exit Direction Changed (Model Code: CJT, CJR, CJL, CJB and CJO)	1-31
	High Precision Specifications (Model Code: HPR)	1-31
	Motor Reversed Direction (Model Code: ML, MR)	1-31
	Reversed-home Specification (Model Code: NM)	1-31
	Slider Roller Specification (Model Code: SR)	1-32
	Vacuum Joint Attachment Opposite Type (Model Code: VR)	1-32
	Double Slider Specification (Model Code: W)	1-32
	Rear Attachment Plate (Model Code: RP)	1-32
	Slider spacer (Model Code: SS)	1-33
1.4	Accessories	1-35
	Motor Cable	1-35
	Encoder Cable	1-36

# 1.1 Checking the Product

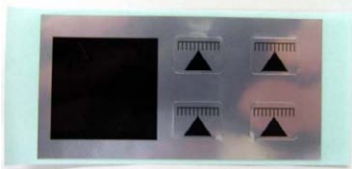
## Parts

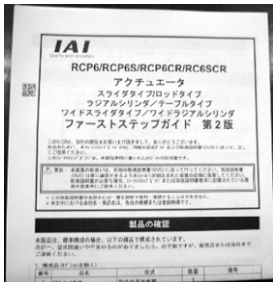
The following table shows the product configuration for the standard specification. See the component list for the details of the enclosed components. If you find any fault or missing parts, contact your local IAI distributor.

Body		Accessories	
<p><u>Actuator Quantity 1</u></p> 	<p><u>Motor Cable Quantity 1</u></p> 	<p><u>Encoder Cable Quantity 1</u></p> 	
Accessories			
<p><u>In-house Made Seals Quantity 1</u></p> 	<p><u>Cross Recessed Pan Head Screw with Captive Washer M3x6 Quantity 2</u></p> <p>For affixing ground cable</p> 	<p><u>Cable Band Quantity 2</u></p> <p>For clamping connector cover</p>  <p>* Refer to International Application Manual (ME0287) for how to use it.</p>	
Accessories (Documents/DVD)			
<p><u>First Step Guide Quantity 1</u></p> 	<p><u>Safety Guide Quantity 1</u></p> 	<p><u>Instruction Manual (DVD) Quantity 1</u></p> 	

## How to Read the Model Nameplate

Model → MODEL: RCS4-SA4C-WA-60-16-300-T2-P-B-CJR  
 Serial number → S/N: A50000000 DATE: 30/10/2017  
 INPUT: DC24V MADE IN JAPAN IAI Corporation CE

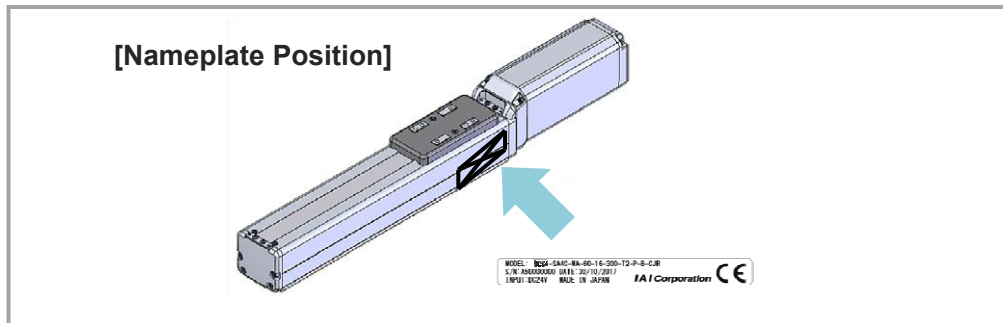

## How to Read the Model Number

**RCS4** — [ ] — **WA** — [ ] — [ ] — [ ] — [ ] — [ ] — [ ]

Series      Type      Encoder Type      Motor Wattage      Ball Screw Lead      Stroke      Applicable Controller      Cable Length      Options

SA4C	Body Width 40mm Coupling Type	WA	Battery-less Absolute	50 to 1100	50mm to 1100mm (Setting available in every 50mm for pitch)	T2	SCON MSCON SSEL XSEL-P/Q XSEL-RA/SA	N None P 1m S 3m M 5m X Length Specification R Robot Cable
SA6C	Body Width 60mm Coupling Type	60	60W	2.5	Lead 2.5mm			B With brake CJT Cable Exit Direction Changed (Top) CJR Cable Exit Direction Changed (Right) CJL Cable Exit Direction Changed (Left) CJO Cable Exit Direction Changed (Outward) CJB Cable Exit Direction Changed (Bottom) HPR High Precision Specifications ML Motor Left Reversed Direction MR Motor Right Reversed Direction NM Reversed-home Specification RP Rear Attachment Plate SS Slider spacer SR Slider Roller Specification W Double Slider Specification
SA7C	Body Width 70mm Coupling Type	100	100W	3	Lead 3mm			
SABC	Body Width 90mm Coupling Type	200	200W	4	Lead 4mm			
SA4R	Body Width 40mm Motor-Reversed Type	400	400W	5	Lead 5mm			
SA6R	Body Width 60mm Motor-Reversed Type			6	Lead 6mm			
SA7R	Body Width 70mm Motor-Reversed Type			8	Lead 8mm			
SABR	Body Width 90mm Motor-Reversed Type			10	Lead 10mm			
				12	Lead 12mm			
				16	Lead 16mm			
				20	Lead 20mm			
				24	Lead 24mm			
				30	Lead 30mm			
				36	Lead 36mm			
				48	Lead 48mm			

\* Please note that the available range of ball screw lead, stroke and options will differ depending on the actuator type.

**RCS4CR** — [ ] — **WA** — [ ] — [ ] — [ ] — [ ] — [ ] — [ ]

















Series      Type      Encoder Type      Motor Wattage      Ball Screw Lead      Stroke      Applicable Controller      Cable Length      Options

SA4C	Body Width 40mm Coupling Type	WA	Battery-less Absolute	50 to 1100	50mm to 1100mm (Setting available in every 50mm for pitch)	T2	SCON MSCON SSEL XSEL-P/Q XSEL-RA/SA	N None P 1m S 3m M 5m X Length Specification R Robot Cable
SA6C	Body Width 60mm Coupling Type	60	60W	2.5	Lead 2.5mm			B With brake CJT Cable Exit Direction Changed (Top) CJR Cable Exit Direction Changed (Right) CJL Cable Exit Direction Changed (Left) CJB Cable Exit Direction Changed (Bottom) HPR High Precision Specifications NM Reversed-home Specification VR Vacuum Joint Attachment Opposite Type W Double Slider Specification
SA7C	Body Width 70mm Coupling Type	100	100W	3	Lead 3mm			
SABC	Body Width 90mm Coupling Type	200	200W	4	Lead 4mm			
		400	400W	5	Lead 5mm			
				6	Lead 6mm			
				8	Lead 8mm			
				10	Lead 10mm			
				12	Lead 12mm			
				16	Lead 16mm			
				20	Lead 20mm			
				24	Lead 24mm			

\* Please note that the available range of ball screw lead, stroke and options will differ depending on the actuator type.









## 1.1 Checking the Product

### Product list

Category	Type	Appearance	Body Width (mm)	Motor Wattage (W)	Lead (mm)	Positioning Repeatability (mm)	Stroke (mm)	Max. Speed (mm/s)	Rated Thrust (N)	Max. Payload (kg)	
										Horizontal	Vertical
Motor Straight Type	SA4C		 40mm	60	16	±0.01 [±0.005]	50 to 500 (Every 50 st)	960	53	10	3
					10			600	85	14	5
					5			300	170	17	8
					2.5			150	340	20	12
	SA6C		 60mm	100	30	±0.01 [±0.005]	50 to 800 (Every 50 st)	1600	57	11	3.5
					20			1200	85	18	6
					12			720	142	30	11
					6			360	283	45	15
	SA7C		 70mm	200	3	±0.01 [±0.005]	50 to 800 (Every 50 st)	180	566	45	15
					24			1800	95	7	4
					16			1500	142	30	7
					8			1000	214	40	12
	SA8C		 90mm	400	4	±0.01 [±0.005]	50 to 1100 (Every 50 st)	500	427	45	20
					20			240	855	50	25
					10			2200	141	8	-
					5			1800	226	30	12
Motor Reversing Type	SA4R		 40mm	60	16	±0.01	50 to 500 (Every 50 st)	960	53	10	2.5
					10			600	85	14	4.5
					5			300	170	17	8
					2.5			150	340	20	12
	SA6R		 60mm	100	30	±0.01	50 to 800 (Every 50 st)	1600	57	11	3
					20			1200	85	18	5
					12			720	142	30	9
					6			360	283	45	15
	SA7R		 70mm	200	3	±0.01	50 to 800 (Every 50 st)	180	566	45	15
					24			1800	95	7	4
					16			1500	142	30	6
					8			1000	214	38	12
	SA8R		 90mm	400	4	±0.01	50 to 1100 (Every 50 st)	500	427	45	18
					20			240	855	50	25
					10			2100	141	8	-
					5			1800	226	30	12

Values in brackets [ ] show specifications for high-precision type

### Cleanroom Type

Category	Type	Appearance	Body Width (mm)	Motor Wattage (W)	Lead (mm)	Positioning Repeatability (mm)	Stroke (mm)	Max. Speed (mm/s)	Rated Thrust (N)	Max. Payload (kg)		Cleanliness	
										Horizontal	Vertical		
Motor Straight Type	SA4C		 40mm	60	16	±0.01 [±0.005]	50 to 500 (Every 50 st)	960	53	10	3	Class 10 (Fed.Std.209D Standards)	
					10			600	85	14	5		
					5			300	170	17	8		
					2.5			150	340	20	12		
	SA6C		 60mm	100	20	±0.01 [±0.005]	50 to 800 (Every 50 st)	1200	85	18	6		
					12			720	142	30	11		
					6			360	283	45	15		
					3			180	566	45	15		
	SA7C		 70mm	200	24	±0.01	50 to 800 (Every 50 st)	1500	142	30	7		Class 2.5 Equivalent (ISO14644-1 Standards)
					16			1000	214	40	12		
					8			500	427	45	20		
					4			240	855	50	25		
	SA8C		 90mm	400	20	±0.01 [±0.005]	50 to 1100 (Every 50 st)	1200	339	60	20		
					10			600	678	80	35		
					5			300	1357	90	45		

Values in brackets [ ] show specifications for high-precision type

## 1.2 Specifications

### Specifications

#### [1] RCS4(CR)-SA4C

##### [Lead and Payload]

Lead (mm)	Max. Payload		Rated Thrust (N)
	Horizontal(kg)	Vertical(kg)	
16	10	3	53
10	14	5	85
5	17	8	170
2.5	20	12	340

##### [Stroke and Max Speed]

Unit: mm/s

Lead (mm)	50 to 450 (Every 50mm)	500 (mm)
16	960	875
10	600	555
5	300	275
2.5	150	135



#### Caution

- The maximum speed may not be achieved when the stroke or movement distance is short or when acceleration/deceleration is set low.
- Setting at or below the minimum speed may lead to abnormal noise or unstable speeds. Do not attempt to set below the minimum speed.
- The minimum speed can be calculated with the equation below.  

$$\text{Minimum speed [mm/s]} = \text{ball screw lead [mm/r]} \div 16384 \text{ [p/r]} \times 1000 \text{ [1/s]}$$
 (mm/r: movement per 1 motor revolution, p/r: pulse per 1 motor revolution)

**[Payload by Acceleration]**

At low load capacity, the acceleration/deceleration can be increased.

**Lead 16**

Horizontal					Vertical				
0.3	0.5	0.7	1.0	1.2	0.3	0.5	0.7	1.0	1.2
10	8	6	6	4	3	3	1.5	1.5	1

**Lead 10**

Horizontal					Vertical				
0.3	0.5	0.7	1.0	1.2	0.3	0.5	0.7	1.0	1.2
14	14	12	10	6	5	5	3	3	2

**Lead 5**

Horizontal					Vertical				
0.3	0.5	0.7	1.0	1.2	0.3	0.5	0.7	1.0	1.2
17	17	15	15	-	8	8	6	6	-

**Lead 2.5**

Horizontal					Vertical				
0.3	0.5	0.7	1.0	1.2	0.3	0.5	0.7	1.0	1.2
20	20	20	-	-	12	12	10	-	-



**Caution**



Do not attempt to configure settings for acceleration/deceleration above the specifications. This may lead to vibration, breakdown, or shortened product life.



**[Actuator Specifications]**

Item	Content
Drive System	Ball Screw $\phi 8\text{mm}$ , Rolled C10
Positioning Repeatability (*1)	$\pm 0.01\text{mm}$ [ $\pm 0.005\text{mm}$ ]
Lost Motion	0.1mm or less
Base	Material: Aluminum, White Anodized
Allowable static moment	Ma direction: 13.0 N·m, Mb direction: 18.6 N·m, Mc direction: 25.3 N·m
Allowable dynamic moment (*2)	Ma direction: 5.0 N·m, Mb direction: 7.1 N·m, Mc direction: 9.7 N·m
No. of Encoder Pulses	16384
Ambient operating temperature/humidity	0 to 40°C, 85%RH or less (Non-condensing)

- Overhang load length guideline: 150mm or less

(\*1) Number in brackets [ ] show the specification for high precision type.

(\*2) For reference rated life of 5000km. The running life differs according to operation conditions and mounting status.

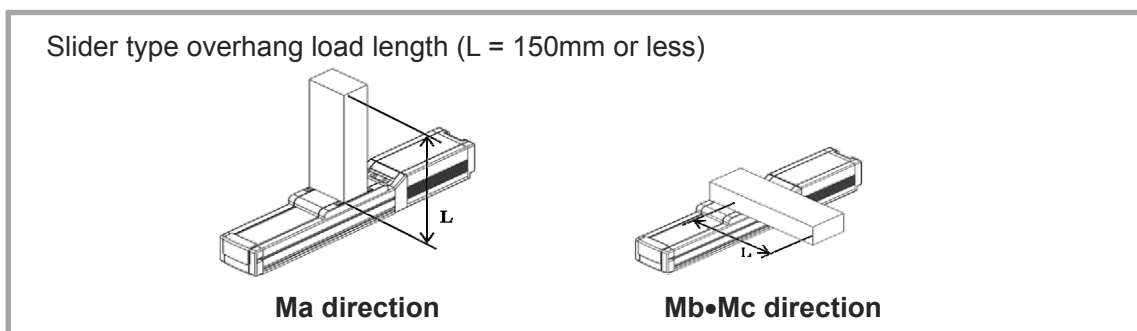
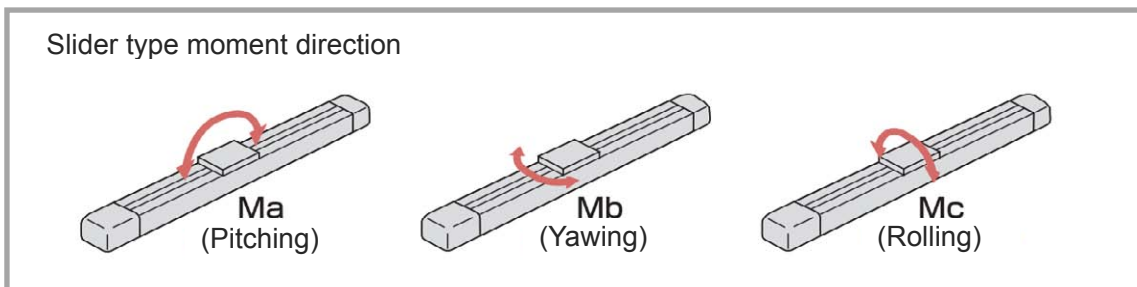

\* For calculation of Ma and Mc moments, take the position pointed with an arrow as the datum.

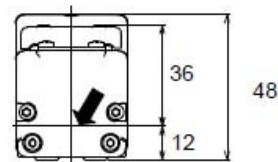

**Caution**

If the actuator is used with excessive allowable moment and overhang load, it may not only lead to abnormal noise and vibration but also significantly reduce the life of the actuator.

**[2] RCS4(CR)-SA6C**

\* There is no Lead 30 prepared for Cleanroom Type RCS4CR-SA6C.

**[Lead and Payload]**

Lead (mm)	Max. Payload		Rated Thrust (N)
	Horizontal(kg)	Vertical(kg)	
30	11	3.5	57
20	18	6	85
12	30	11	142
6	45	15	283
3	45	15	566

**[Stroke and Max Speed]**

Unit: mm/s

Lead (mm)	50 to 500 (Every 50mm)	550 (mm)	600 (mm)	650 (mm)	700 (mm)	750 (mm)	800 (mm)
30	1600		1450	1260	1100	970	860
20	1200	1130	970	840	735	650	575
12	720	620	535	460	405	355	315
6	360	305	265	230	200	175	155
3	180	150	130	115	100	85	75

**Caution**

- The maximum speed may not be achieved when the stroke or movement distance is short or when acceleration/deceleration is set low.
- Setting at or below the minimum speed may lead to abnormal noise or unstable speeds.  
Do not attempt to set below the minimum speed.
- The minimum speed can be calculated with the equation below.  
Minimum speed [mm/s] = ball screw lead [mm/r] ÷ 16384 [p/r] × 1000 [1/s]  
(mm/r: movement per 1 motor revolution, p/r: pulse per 1 motor revolution)

**[Payload by Acceleration]**

At low load capacity, the acceleration/deceleration can be increased.

**Lead30**

Horizontal					Vertical				
0.3	0.5	0.7	1.0	1.2	0.3	0.5	0.7	1.0	1.2
11	6	6	4	3	3.5	2	2	1.5	1.5

**Lead20**

Horizontal					Vertical				
0.3	0.5	0.7	1.0	1.2	0.3	0.5	0.7	1.0	1.2
18	15	10	8	6	6	5	4	4	2

**Lead12**

Horizontal					Vertical				
0.3	0.5	0.7	1.0	1.2	0.3	0.5	0.7	1.0	1.2
30	24	20	15	15	11	10	10	8	8

**Lead6**

Horizontal					Vertical				
0.3	0.5	0.7	1.0	1.2	0.3	0.5	0.7	1.0	1.2
45	30	20	20	-	15	15	15	15	-

**Lead3**

Horizontal					Vertical				
0.3	0.5	0.7	1.0	1.2	0.3	0.5	0.7	1.0	1.2
45	30	20	-	-	15	14	10	-	-

**Caution**

Do not attempt to configure settings for acceleration/deceleration above the specifications. This may lead to vibration, breakdown, or shortened product life.

**[Actuator Specifications]**

Item	Content
Drive System	Ball Screw $\phi$ 10mm, Rolled C10
Positioning Repeatability (*1)	$\pm 0.01\text{mm}$ [ $\pm 0.005\text{mm}$ ]
Lost Motion	0.1mm or less
Base	Material: Aluminum White Anodized
Allowable static moment	Ma direction: 48.5 N•m, Mb direction: 69.3 N•m, Mc direction: 103 N•m
Allowable dynamic moment (*2)	Ma direction: 11.6 N•m, Mb direction: 16.6 N•m, Mc direction: 24.6 N•m
No. of Encoder Pulses	16384
Ambient operating temperature/humidity	0 to 40°C, 85%RH or less (Non-condensing)

• Overhang load length guideline: 220mm or less

(\*1) Number in brackets [ ] show the specification for high precision type.

(\*2) For reference rated life of 5000km. The running life differs according to operation conditions and mounting status.

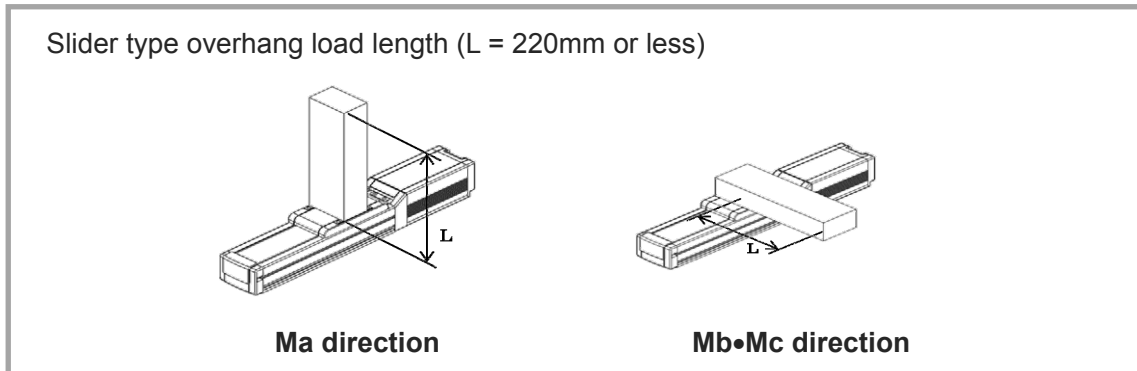
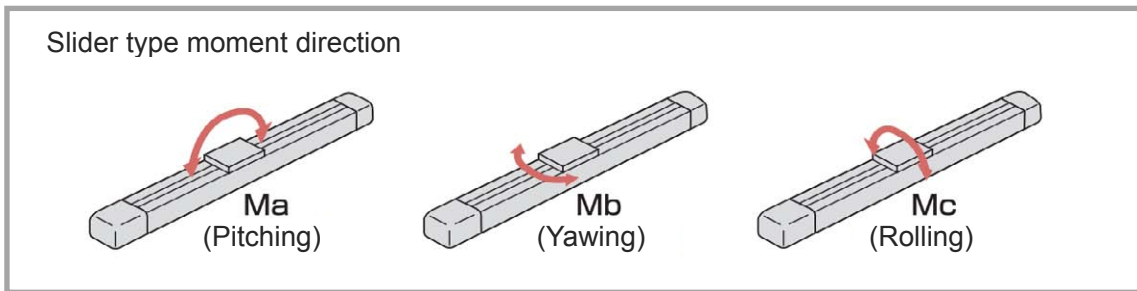

\* For calculation of Ma and Mc moments, take the position pointed with an arrow as the datum.

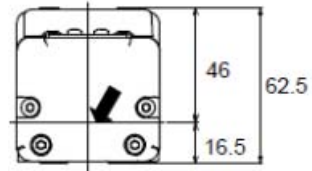

**Caution**

If the actuator is used with excessive allowable moment and overhang load, it may not only lead to abnormal noise and vibration but also significantly reduce the life of the actuator.

**[3] RCS4(CR)-SA7C**

\* There is no Lead 36 prepared for Cleanroom Type RCS4CR-SA7C.

**[Lead and Payload]**

Lead (mm)	Max. Payload		Rated Thrust (N)
	Horizontal(kg)	Vertical(kg)	
36	7	4	95
24	30	7	142
16	40	12	214
8	45	20	427
4	50	25	855

**[Stroke and Max Speed]**

Unit: mm/s

Lead (mm)	50 to 500 (Every 50mm)	550 (mm)	600 (mm)	650 (mm)	700 (mm)	750 (mm)	800 (mm)
36	1800			1620	1420	1260	1120
24	1500	1440	1240	1095	965	850	760
16	1000	965	830	720	635	560	500
8	500	475	410	355	315	275	245
4	240	235	205	175	155	135	120

**Caution**

- The maximum speed may not be achieved when the stroke or movement distance is short or when acceleration/deceleration is set low.
- Setting at or below the minimum speed may lead to abnormal noise or unstable speeds. Do not attempt to set below the minimum speed.
- The minimum speed can be calculated with the equation below.  

$$\text{Minimum speed [mm/s]} = \text{ball screw lead [mm/r]} \div 16384 \text{ [p/r]} \times 1000 \text{ [1/s]}$$
 (mm/r: movement per 1 motor revolution, p/r: pulse per 1 motor revolution)

**[Payload by Acceleration]**

At low load capacity, the acceleration/deceleration can be increased.

**Lead 36**

Horizontal					Vertical				
0.3	0.5	0.7	1.0	1.2	0.3	0.5	0.7	1.0	1.2
7	7	6	4	3	4	4	3	2	2

**Lead 24**

Horizontal					Vertical				
0.3	0.5	0.7	1.0	1.2	0.3	0.5	0.7	1.0	1.2
30	12	10	6	5	7	7	6	5	4

**Lead 16**

Horizontal					Vertical				
0.3	0.5	0.7	1.0	1.2	0.3	0.5	0.7	1.0	1.2
40	30	15	15	12	12	12	10	8	8

**Lead 8**

Horizontal					Vertical				
0.3	0.5	0.7	1.0	1.2	0.3	0.5	0.7	1.0	1.2
45	40	40	35	-	20	20	20	18	-

**Lead 4**

Horizontal					Vertical				
0.3	0.5	0.7	1.0	1.2	0.3	0.5	0.7	1.0	1.2
50	50	40	-	-	25	25	20	-	-



**Caution**



Do not attempt to configure settings for acceleration/deceleration above the specifications. This may lead to vibration, breakdown, or shortened product life.

**[Actuator Specifications]**

Item	Content
Drive System	Ball Screw $\phi$ 12mm, Rolled C10
Positioning Repeatability (*1)	$\pm 0.01\text{mm}[\pm 0.005\text{mm}]$
Lost Motion	0.1 mm or less
Base	Material: Aluminum, White Anodized
Allowable static moment	Ma direction:115 N•m,Mb direction:115 N•m,Mc direction:229 N•m
Allowable dynamic moment (*2)	Ma direction:44.7 N•m,Mb direction:44.7 N•m,Mc direction:89.1 N•m
No. of Encoder Pulses	16384
Ambient operating temperature/humidity	0 to 40°C, 85%RH or less (Non-condensing)

• Overhang load length guideline:300mm or less

(\*1) Number in brackets [ ] show the specification for high precision type.

(\*2) For reference rated life of 5000km. The running life differs according to operation conditions and mounting status.

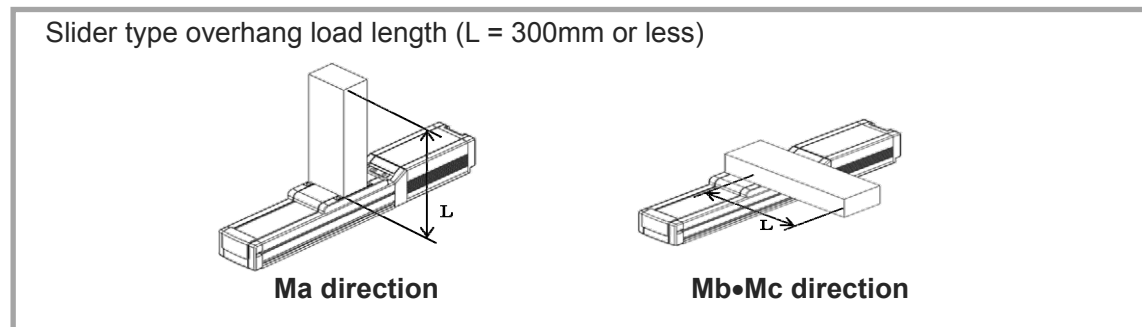
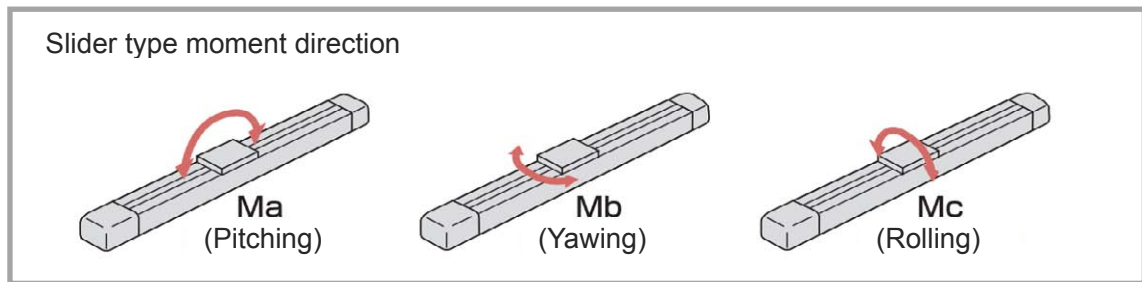

\* For calculation of Ma and Mc moments, take the position pointed with an arrow as the datum.

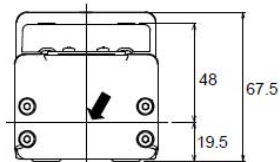

**Caution**

If the actuator is used with excessive allowable moment and overhang load, it may not only lead to abnormal noise and vibration but also significantly reduce the life of the actuator.

**[4] RCS4(CR)-SA8C**

\* There is no Lead 30 and Lead 48 prepared for Cleanroom Type RCS4CR-SA8C.

**[Lead and Payload]**

Lead (mm)	Max. Payload		Rated Thrust (N)
	Horizontal(kg)	Vertical(kg)	
48	8	–	141
30	30	12	226
20	60	20	339
10	80	35	678
5	90	45	1357

**[Stroke and Max Speed]**

Unit: mm/s

Lead (mm)	50 to 600 (Every 50mm)	650 (mm)	700 (mm)	750 (mm)	800 (mm)	850 (mm)	900 (mm)	950 (mm)	1000 (mm)	1050 (mm)	1100 (mm)
48	2200			2180	1950	1760	1590	1450	1320	1210	1110
30	1800	1640	1440	1280	1155	1040	940	855	780	715	660
20	1200	1090	960	860	770	695	630	570	520	480	440
10	600	540	480	430	385	345	310	285	260	235	220
5	300	270	240	215	190	175	155	140	130	120	110



**Caution**

- The maximum speed may not be achieved when the stroke or movement distance is short or when acceleration/deceleration is set low.
- Setting at or below the minimum speed may lead to abnormal noise or unstable speeds. Do not attempt to set below the minimum speed.
- The minimum speed can be calculated with the equation below.  

$$\text{Minimum speed [mm/s]} = \text{ball screw lead [mm/r]} \div 16384 \text{ [p/r]} \times 1000 \text{ [1/s]}$$
 (mm/r: movement per 1 motor revolution, p/r: pulse per 1 motor revolution)



**[Payload by Acceleration]**

At low load capacity, the acceleration/deceleration can be increased.

**Lead 48**

Horizontal					Vertical				
0.3	0.5	0.7	1.0	1.2	0.3	0.5	0.7	1.0	1.2
8	8	8	5	4	-	-	-	-	-

**Lead 30**

Horizontal					Vertical				
0.3	0.5	0.7	1.0	1.2	0.3	0.5	0.7	1.0	1.2
30	25	20	15	10	12	12	10	8	6

**Lead 20**

Horizontal					Vertical				
0.3	0.5	0.7	1.0	1.2	0.3	0.5	0.7	1.0	1.2
60	40	30	20	15	20	20	18	15	12

**Lead 10**

Horizontal					Vertical				
0.3	0.5	0.7	1.0	1.2	0.3	0.5	0.7	1.0	1.2
80	80	70	60	-	35	35	35	30	-

**Lead 5**

Horizontal					Vertical				
0.3	0.5	0.7	1.0	1.2	0.3	0.5	0.7	1.0	1.2
90	90	70	-	-	45	45	35	-	-

**Caution**

Do not attempt to configure settings for acceleration/deceleration above the specifications. This may lead to vibration, breakdown, or shortened product life.

**[Actuator Specifications]**

Item	Content
Drive System	Ball Screw $\phi$ 16mm, Rolled C10
Positioning Repeatability (*1)	$\pm 0.01\text{mm}[\pm 0.005\text{mm}]$
Lost Motion	0.1mm or less
Base	Material: Aluminum, White Anodized
Allowable static moment	Ma direction:219 N•m, Mb direction:219 N•m, Mc direction:414 N•m
Allowable dynamic moment (*2)	Ma direction:77.0 N•m, Mb direction:77.0 N•m, Mc direction:146 N•m
No. of Encoder Pulses	16384
Ambient operating temperature/humidity	0 to 40°C, 85%RH or less (Non-condensing)

• Overhang load length guideline:400mm or less

(\*1) Number in brackets [ ] show the specification for high precision type.

(\*2) For reference rated life of 5000km. The running life differs according to operation conditions and mounting status.

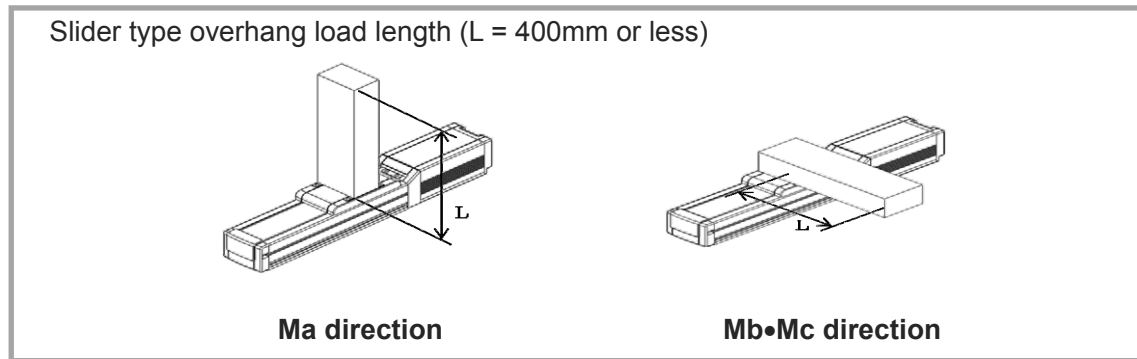
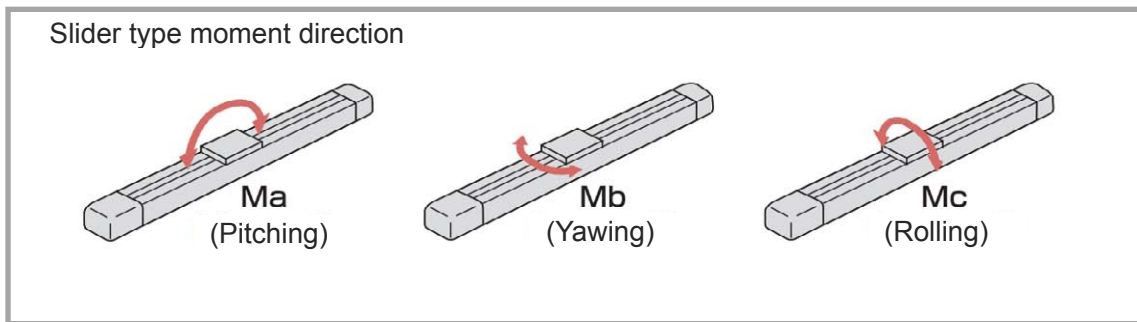

\*For calculation of Ma and Mc moments, take the position pointed with an arrow as the datum.

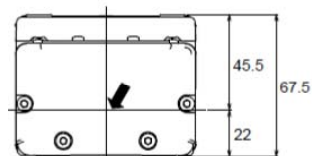

**Caution**

If the actuator is used with excessive allowable moment and overhang load, it may not only lead to abnormal noise and vibration but also significantly reduce the life of the actuator.

**[5] RCS4-SA4R****[Lead and Payload]**

Lead (mm)	Max. Payload		Rated Thrust (N)
	Horizontal(kg)	Vertical(kg)	
16	10	2.5	53
10	14	4.5	85
5	17	8	170
2.5	20	12	340

**[Stroke and Max Speed]**

Unit: mm/s

Lead (mm)	50 to 450 (Every 50mm)	500 (mm)
16	960	875
10	600	555
5	300	275
2.5	150	135

**Caution**

- The maximum speed may not be achieved when the stroke or movement distance is short or when acceleration/deceleration is set low.
- Setting at or below the minimum speed may lead to abnormal noise or unstable speeds. Do not attempt to set below the minimum speed.
- The minimum speed can be calculated with the equation below.  

$$\text{Minimum speed [mm/s]} = \text{ball screw lead [mm/r]} \div 16384 \text{ [p/r]} \times 1000 \text{ [1/s]}$$
 (mm/r: movement per 1 motor revolution, p/r: pulse per 1 motor revolution)

**[Payload by Acceleration]**

At low load capacity, the acceleration/deceleration can be increased.

**Lead 16**

Horizontal					Vertical				
0.3	0.5	0.7	1.0	1.2	0.3	0.5	0.7	1.0	1.2
10	8	6	6	-	2.5	2.5	1.5	1.5	-

**Lead 10**

Horizontal					Vertical				
0.3	0.5	0.7	1.0	1.2	0.3	0.5	0.7	1.0	1.2
14	14	12	10	-	4.5	4.5	3	3	-

**Lead 5**

Horizontal					Vertical				
0.3	0.5	0.7	1.0	1.2	0.3	0.5	0.7	1.0	1.2
17	17	15	13	-	8	8	6	6	-

**Lead 2.5**

Horizontal					Vertical				
0.3	0.5	0.7	1.0	1.2	0.3	0.5	0.7	1.0	1.2
20	20	20	-	-	12	12	10	-	-



**Caution**

Do not attempt to configure settings for acceleration/deceleration above the specifications. This may lead to vibration, breakdown, or shortened product life.

**[Actuator Specifications]**

Item	Content
Drive System	Ball Screw $\phi 8\text{mm}$ , Rolled C10
Positioning Repeatability (*1)	$\pm 0.01\text{mm}[\pm 0.005\text{mm}]$
Lost Motion	0.1mm or less
Base	Material: Aluminum, White Anodized
Allowable static moment	Ma direction: 13.0 N•m, Mb direction: 18.6 N•m, Mc direction: 25.3 N•m
Allowable dynamic moment (*2)	Ma direction: 5.0 N•m, Mb direction: 7.1 N•m, Mc direction: 9.7 N•m
No. of Encoder Pulses	16384
Ambient operating temperature/humidity	0 to 40°C, 85%RH or less (Non-condensing)

• Overhang load length guideline: 150mm or less

(\*1) Number in brackets [ ] show the specification for high precision type.

(\*2) For reference rated life of 5000km. The running life differs according to operation conditions and mounting status.

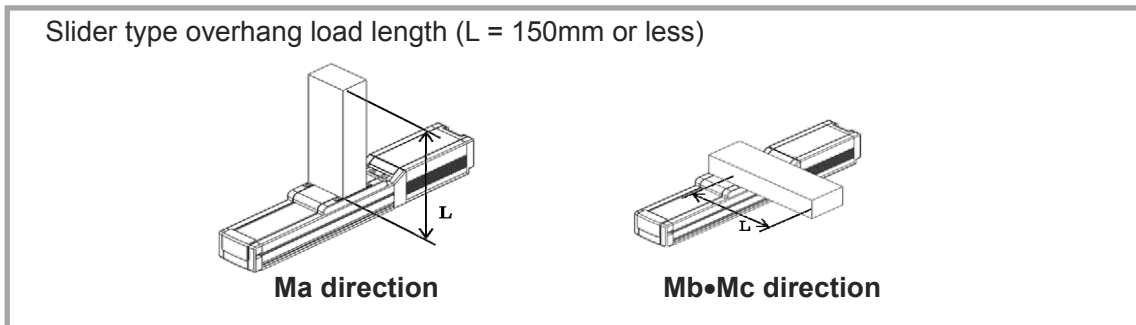
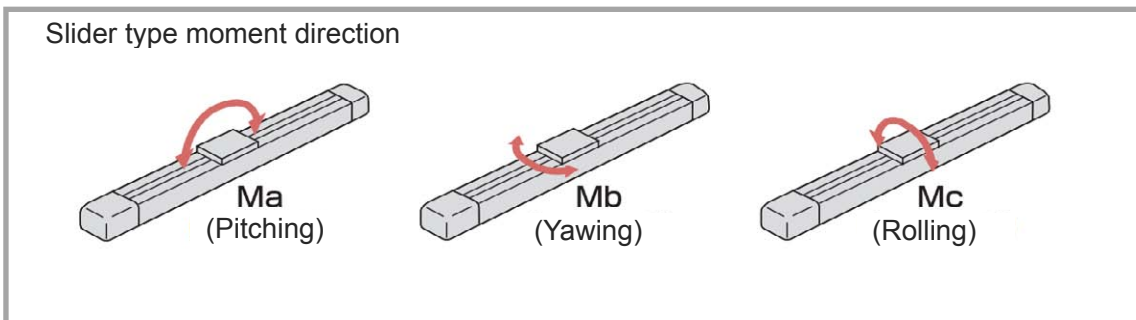

\* For calculation of Ma and Mc moments, take the position pointed with an arrow as the datum.

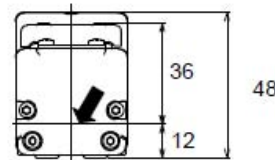

**Caution**

If the actuator is used with excessive allowable moment and overhang load, it may not only lead to abnormal noise and vibration but also significantly reduce the life of the actuator.

**[6] RCS4-SA6R****[Lead and Payload]**

Lead (mm)	Max. Payload		Rated Thrust (N)
	Horizontal(kg)	Vertical(kg)	
30	11	3	57
20	18	5	85
12	30	9	142
6	45	15	283
3	45	15	566

**[Stroke and Max Speed]**

Unit: mm/s

Lead (mm)	50 to 500 (Every 50mm)	550 (mm)	600 (mm)	650 (mm)	700 (mm)	750 (mm)	800 (mm)
30	1600		1450	1260	1100	970	860
20	1200	1130	970	840	735	650	575
12	720	620	535	460	405	355	315
6	360	305	265	230	200	175	155
3	180	150	130	115	100	85	75

**Caution**

- The maximum speed may not be achieved when the stroke or movement distance is short or when acceleration/deceleration is set low.
- Setting at or below the minimum speed may lead to abnormal noise or unstable speeds. Do not attempt to set below the minimum speed.
- The minimum speed can be calculated with the equation below.  

$$\text{Minimum speed [mm/s]} = \text{ball screw lead [mm/r]} \div 16384 \text{ [p/r]} \times 1000 \text{ [1/s]}$$
 (mm/r: movement per 1 motor revolution, p/r: pulse per 1 motor revolution)

**[Payload by Acceleration]**

At low load capacity, the acceleration/deceleration can be increased.

Lead 30

Horizontal					Vertical				
0.3	0.5	0.7	1.0	1.2	0.3	0.5	0.7	1.0	1.2
11	6	6	4	–	3	2	2	1.5	–

Lead 20

Horizontal					Vertical				
0.3	0.5	0.7	1.0	1.2	0.3	0.5	0.7	1.0	1.2
18	15	10	8	–	5	5	4	4	–

Lead 12

Horizontal					Vertical				
0.3	0.5	0.7	1.0	1.2	0.3	0.5	0.7	1.0	1.2
30	24	20	15	–	9	9	9	8	–

Lead 6

Horizontal					Vertical				
0.3	0.5	0.7	1.0	1.2	0.3	0.5	0.7	1.0	1.2
45	30	20	20	–	15	15	15	15	–

Lead 3

Horizontal					Vertical				
0.3	0.5	0.7	1.0	1.2	0.3	0.5	0.7	1.0	1.2
45	30	20	–	–	15	14	10	–	–

**Caution**

Do not attempt to configure settings for acceleration/deceleration above the specifications. This may lead to vibration, breakdown, or shortened product life.

**[Actuator Specifications]**

Item	Content
Drive System	Ball Screw $\phi 10\text{mm}$ , Rolled C10
Positioning Repeatability (*1)	$\pm 0.01\text{mm}[\pm 0.005\text{mm}]$
Lost Motion	0.1 mm or less
Base	Material: Aluminum, White Anodized
Allowable static moment	Ma direction: 48.5 N•m, Mb direction: 69.3 N•m, Mc direction: 103 N•m
Allowable dynamic moment (*2)	Ma direction: 11.6 N•m, Mb direction: 16.6 N•m, Mc direction: 24.6 N•m
No. of Encoder Pulses	16384
Ambient operating temperature/humidity	0 to 40°C, 85%RH or less (Non-condensing)

• Overhang load length guideline: 220mm or less

(\*1) Number in brackets [ ] show the specification for high precision type.

(\*2) For reference rated life of 5000km. The running life differs according to operation conditions and mounting status.

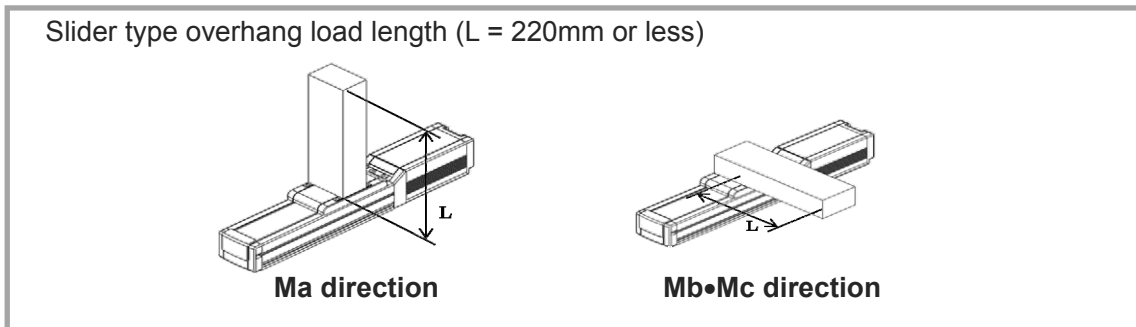
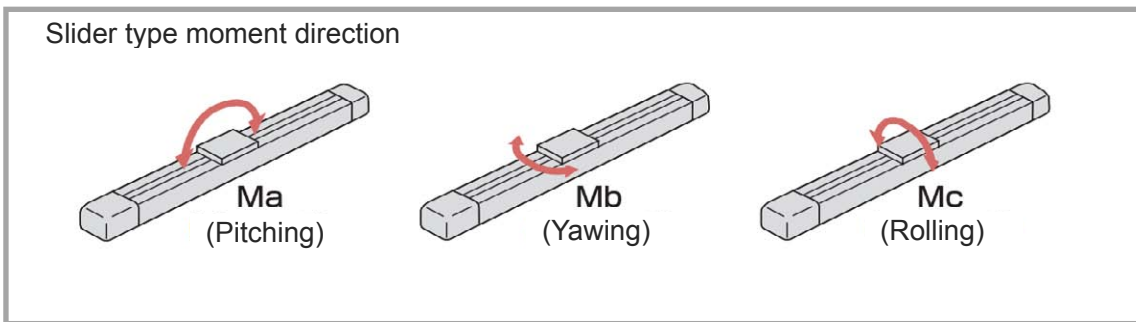

\* For calculation of Ma and Mc moments, take the position pointed with an arrow as the datum.

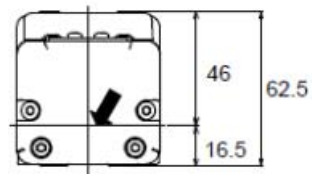

**Caution**

If the actuator is used with excessive allowable moment and overhang load, it may not only lead to abnormal noise and vibration but also significantly reduce the life of the actuator.



**[7] RCS4-SA7R****[Lead and Payload]**

Lead (mm)	Max. Payload		Rated Thrust (N)
	Horizontal(kg)	Vertical(kg)	
36	7	4	95
24	30	6	142
16	38	12	214
8	45	18	427
4	50	25	855

**[Stroke and Max Speed]**

Unit: mm/s

Lead (mm)	50 to 500 (Every 50mm)	550 (mm)	600 (mm)	650 (mm)	700 (mm)	750 (mm)	800 (mm)
36	1800			1620	1420	1260	1120
24	1500	1440	1240	1095	965	850	760
16	1000	965	830	720	635	560	500
8	500	475	410	355	315	275	245
4	240	235	205	175	155	135	120

**Caution**

- The maximum speed may not be achieved when the stroke or movement distance is short or when acceleration/deceleration is set low.
- Setting at or below the minimum speed may lead to abnormal noise or unstable speeds. Do not attempt to set below the minimum speed.
- The minimum speed can be calculated with the equation below.  

$$\text{Minimum speed [mm/s]} = \text{ball screw lead [mm/r]} \div 16384 \text{ [p/r]} \times 1000 \text{ [1/s]}$$
 (mm/r: movement per 1 motor revolution, p/r: pulse per 1 motor revolution)

**[Payload by Acceleration]**

At low load capacity, the acceleration/deceleration can be increased.

**Lead 36**

Horizontal					Vertical				
0.3	0.5	0.7	1.0	1.2	0.3	0.5	0.7	1.0	1.2
7	7	6	4	-	4	4	3	2	-

**Lead 24**

Horizontal					Vertical				
0.3	0.5	0.7	1.0	1.2	0.3	0.5	0.7	1.0	1.2
30	12	10	6	-	6	6	5	5	-

**Lead 16**

Horizontal					Vertical				
0.3	0.5	0.7	1.0	1.2	0.3	0.5	0.7	1.0	1.2
38	30	15	15	-	12	12	10	8	-

**Lead 8**

Horizontal					Vertical				
0.3	0.5	0.7	1.0	1.2	0.3	0.5	0.7	1.0	1.2
45	40	40	35	-	18	18	18	16	-

**Lead 4**

Horizontal					Vertical				
0.3	0.5	0.7	1.0	1.2	0.3	0.5	0.7	1.0	1.2
50	50	40	-	-	25	25	20	-	-



**Caution**

Do not attempt to configure settings for acceleration/deceleration above the specifications. This may lead to vibration, breakdown, or shortened product life.

**[Actuator Specifications]**

Item	Content
Drive System	Ball Screw $\phi 12\text{mm}$ , Rolled C10
Positioning Repeatability (*1)	$\pm 0.01\text{mm}[\pm 0.005\text{mm}]$
Lost Motion	0.1mm or less
Base	Material: Aluminum, White Anodized
Allowable static moment	Ma direction:115 N•m, Mb direction:115 N•m, Mc direction:229 N•m
Allowable dynamic moment (*2)	Ma direction:44.7 N•m, Mb direction:44.7 N•m, Mc direction:89.1 N•m
No. of Encoder Pulses	16384
Ambient operating temperature/humidity	0 to 40°C 85%RH or less (Non-condensing)

• Overhang load length guideline:300mm or less

(\*1) Number in brackets [ ] show the specification for high precision type.

(\*2) For reference rated life of 5000km. The running life differs according to operation conditions and mounting status.

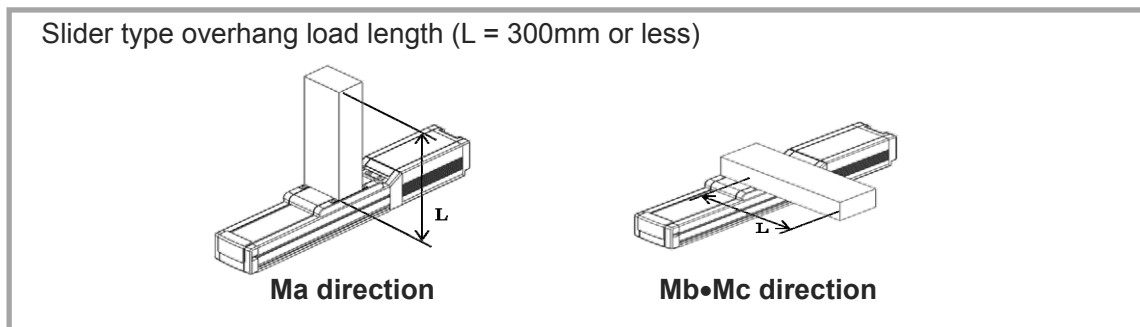
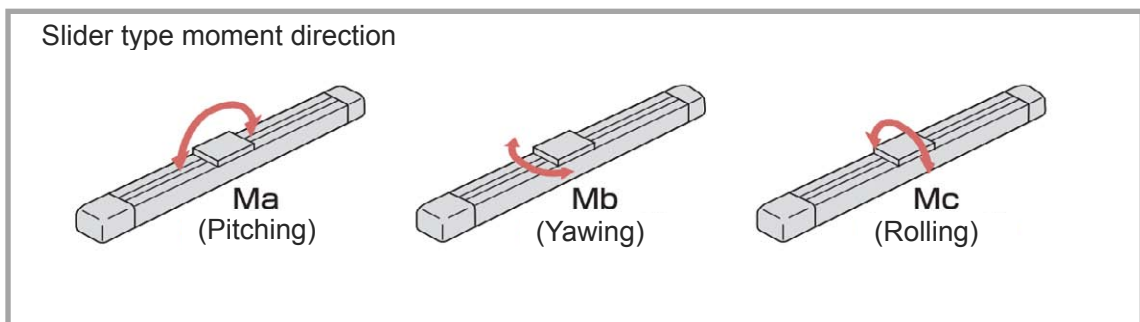

\* For calculation of Ma and Mc moments, take the position pointed with an arrow as the datum.

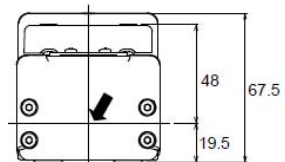

**Caution**

If the actuator is used with excessive allowable moment and overhang load, it may not only lead to abnormal noise and vibration but also significantly reduce the life of the actuator.

**[8] RCS4-SA8R**

**[Lead and Payload]**

Lead (mm)	Max. Payload		Rated Thrust (N)
	Horizontal(kg)	Horizontal(kg)	
48	8	-	141
30	30	12	226
20	60	20	339
10	80	35	678
5	90	45	1357

**[Stroke and Max Speed]**

Unit: mm/s

Lead (mm)	50 to 600 (Every 50mm)	650 (mm)	700 (mm)	750 (mm)	800 (mm)	850 (mm)	900 (mm)	950 (mm)	1000 (mm)	1050 (mm)	1100 (mm)
48	2100				1950	1760	1590	1450	1320	1210	1110
30	1800	1640	1440	1280	1155	1040	940	855	780	715	660
20	1200	1090	960	860	770	695	630	570	520	480	440
10	600	540	480	430	385	345	310	285	260	235	220
5	300	270	240	215	190	175	155	140	130	120	110



**Caution**

- The maximum speed may not be achieved when the stroke or movement distance is short or when acceleration/deceleration is set low.
- Setting at or below the minimum speed may lead to abnormal noise or unstable speeds. Do not attempt to set below the minimum speed.
- The minimum speed can be calculated with the equation below.  
 Minimum speed [mm/s] = ball screw lead [mm/r] ÷ 16384 [p/r] × 1000 [1/s]  
 (mm/r: movement per 1 motor revolution, p/r: pulse per 1 motor revolution)

**[Payload by Acceleration]**

At low load capacity, the acceleration/deceleration can be increased.

Lead 48

Horizontal					Vertical				
0.3	0.5	0.7	1.0	1.2	0.3	0.5	0.7	1.0	1.2
8	8	8	5	–	–	–	–	–	–

Lead 30

Horizontal					Vertical				
0.3	0.5	0.7	1.0	1.2	0.3	0.5	0.7	1.0	1.2
30	25	20	15	–	12	12	10	8	–

Lead 20

Horizontal					Vertical				
0.3	0.5	0.7	1.0	1.2	0.3	0.5	0.7	1.0	1.2
60	40	30	20	–	20	20	18	15	–

Lead 10

Horizontal					Vertical				
0.3	0.5	0.7	1.0	1.2	0.3	0.5	0.7	1.0	1.2
80	80	70	60	–	35	35	35	30	–

Lead 5

Horizontal					Vertical				
0.3	0.5	0.7	1.0	1.2	0.3	0.5	0.7	1.0	1.2
90	90	70	–	–	45	45	35	–	–

**Caution**

Do not attempt to configure settings for acceleration/deceleration above the specifications. This may lead to vibration, breakdown, or shortened product life.

**[Actuator Specifications]**

Item	Content
Drive System	Ball Screw $\phi 16\text{mm}$ , Rolled C10
Positioning Repeatability (*1)	$\pm 0.01\text{mm}[\pm 0.005\text{mm}]$
Lost Motion	0.1mm or less
Base	Material: Aluminum, White Anodized
Allowable static moment	Ma direction: 219 N•m, Mb direction: 219 N•m, Mc direction: 414 N•m
Allowable dynamic moment (*2)	Ma direction: 77.0 N•m, Mb direction: 77.0 N•m, Mc direction: 146 N•m
No. of Encoder Pulses	16384
Ambient operating temperature/humidity	0 to 40°C, 85%RH or less (Non-condensing)

• Overhang load length guideline: 400mm or less

(\*1) Number in brackets [ ] show the specification for high precision type.

(\*2) For reference rated life of 5000km. The running life differs according to operation conditions and mounting status.

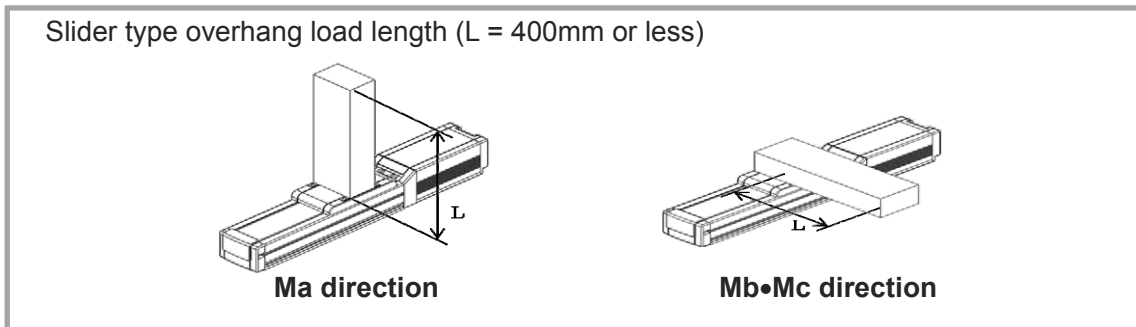
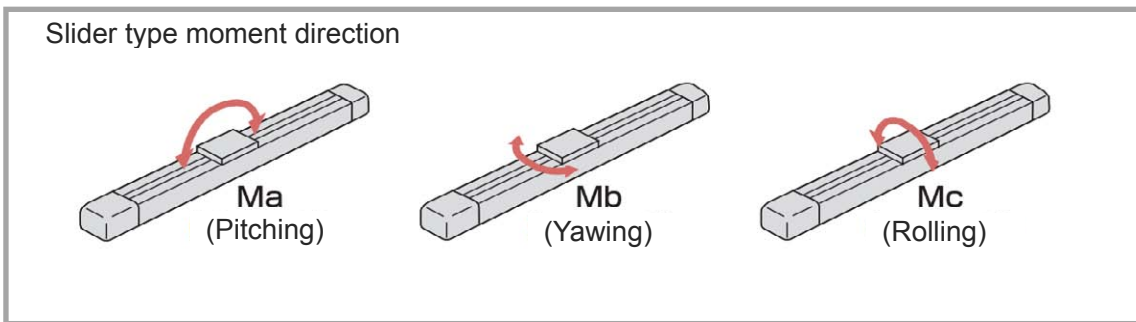

\* For calculation of Ma and Mc moments, take the position pointed with an arrow as the datum.

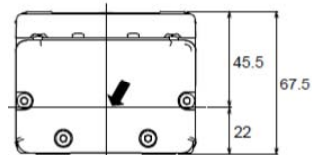

**Caution**

If the actuator is used with excessive allowable moment and overhang load, it may not only lead to abnormal noise and vibration but also significantly reduce the life of the actuator.

## Double Slider (Option)

[Table for Double Slider Type]

Name of Type	Allowable dynamic moment						Allowable static moment			Overhang load length (mm)	Slider Mass (kg)	Slider length (mm)	Min. Effective Stroke for Double Slider (mm)
	Standard rated life (km)	Slider Span (mm)		Ma direction (N·m)	Mb direction (N·m)	Mc direction (N·m)	Ma direction (N·m)	Mb direction (N·m)	Mc direction (N·m)				
		Actual Slider Span	Slider Cover Span							Ma direction Mb·Mc direction			
SA4	5000	60	24	44.6	63.6	15.7	143	204	50.5	420	1	76	50
SA6	5000	90	40	106	152	40	546	779	205	630	2	110	50
SA7	5000	70	20	285	285	145	900	900	458	810	2	130	50
SA8	5000	120	35	565	565	237	1980	1980	828	1200	2.5	165	50

[Figure of Double Slider]

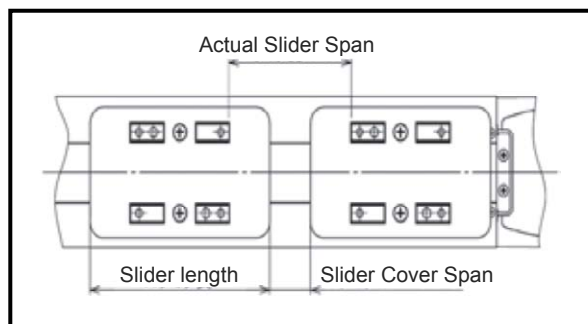

### Caution

If double slider (option) is ordered, consider the available stroke should be the value that the length of slider and slider cover span are subtracted from the stroke shown in the model code. Therefore, add the following number to the necessary stroke when indicate the stroke at order. Also, make sure that the “necessary stroke” should be the minimum effective stroke of the double slider type or above.

Stroke Length to Order (Nominal Stroke)
“Necessary Stroke” + “Slider Cover Span” + “Slider Length” or more

- The payload of the double slider should consider the weight of the slider itself subtracted from the performance in the specification for the maximum.
- When you consider the maximum velocity, consider the stroke length to order (nominal stroke) as the value of stroke in [Stroke and Max Speed].

## Duty ratio

The duty ratio is the operating rate, shown in %, of the actuator operating time within one cycle.

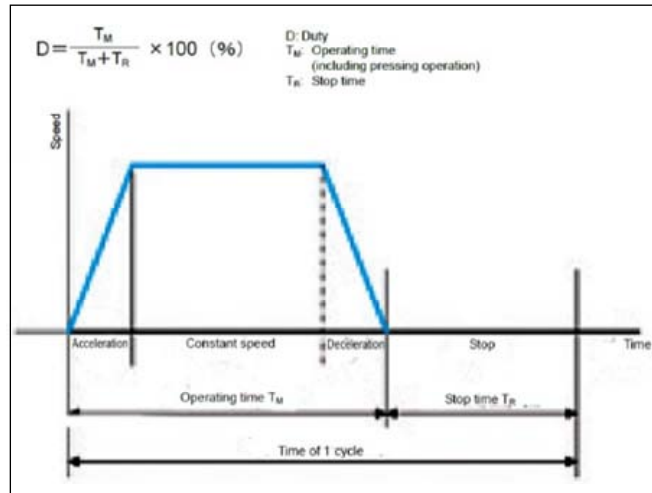

As the reference for duty available to use may differ depending on the operation conditions (payload, acceleration / deceleration, etc.), it is necessary to figure out the load factor LF and acceleration / deceleration time ratio  $t_{od}$  using the calculation formulae below and find it out from the graph.

### 1) Figure out the load factor LF using the calculation formulae below.

Maximum payload at the acceleration 0.3G is described in 1.2 Specifications.

<p>[When indicated acceleration / deceleration is at acceleration / deceleration 0.3G or below]</p> <p>Load Factor: <math>LF = \frac{M \times \alpha}{M_r \times 0.3}</math> [%]</p> <p>Max. Payload at Acceleration 0.3G : <math>M_r</math> [kg]</p> <p>Acceleration / Deceleration 0.3G : 0.3 [G]</p> <p>Payload during Operation : <math>M</math> [kg]</p> <p>Acceleration during Operation : <math>\alpha</math> [G]</p>	<p>[When indicated acceleration / deceleration is at acceleration / deceleration 0.3G or above]</p> <p>Load Factor: <math>LF = \frac{M \times \alpha}{M_d \times \alpha} = \frac{M}{M_d}</math> [%]</p> <p>Payload at Indicated Acceleration : <math>M_d</math> [kg]</p> <p>Payload during Operation : <math>M</math> [kg]</p> <p>Acceleration during Operation : <math>\alpha</math> [G]</p>
--	---

### 2) Figure out the acceleration / deceleration time ratio $t_{od}$ using the calculation formulae below.

Acceleration / Deceleration Time Ratio  $t_{od}$  =

$$\frac{\text{Acceleration Time during Operation} + \text{Deceleration Time during Operation}}{\text{Duration of Operation}} \text{ [%]}$$

$$\text{Acceleration Time} = \frac{\text{Velocity during Operation [mm/s]}}{\text{Acceleration during Operation [mm/s}^2\text{] [sec]}}$$

$$\text{Acceleration [mm/s}^2\text{]} = \text{Acceleration [G]} \times 9,800\text{mm/s}^2$$

$$\text{Deceleration Time} = \frac{\text{Velocity during Operation [mm/s]}}{\text{Deceleration during Operation [mm/s}^2\text{] [sec]}}$$

$$\text{Deceleration [mm/s}^2\text{]} = \text{Deceleration [G]} \times 9,800\text{mm/s}^2$$



3) Read a reference for duty with the figured out “Load Factor” and “Acceleration / Deceleration Time Ratio”.

e.g.) The reference for duty when the load factor LF is 80% and the acceleration / deceleration time ratio  $t_{od}$  is 80% should be approximately 75%.

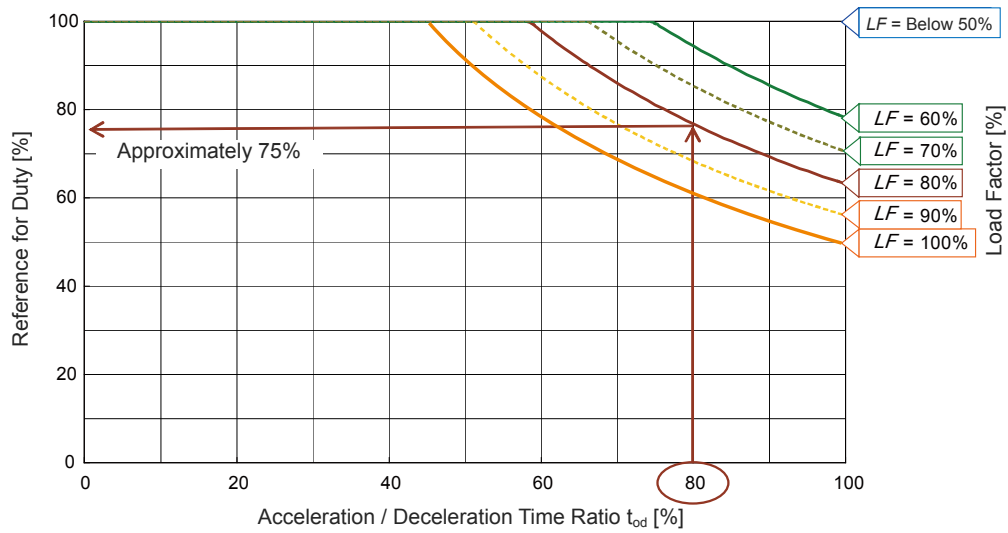

## 1.3 Options

### With brake (Model Code: B)

This is used to prevent the slider from moving during power outages or when the servo is OFF. It can also be used to prevent the slider from falling when mounted vertically.

### Cable Exit Direction Changed (Model Code: CJT, CJR, CJL, CJB and CJO)

The orientation of the motor / encoder cable to be installed on the actuator unit can be changed to top/bottom/right/left.

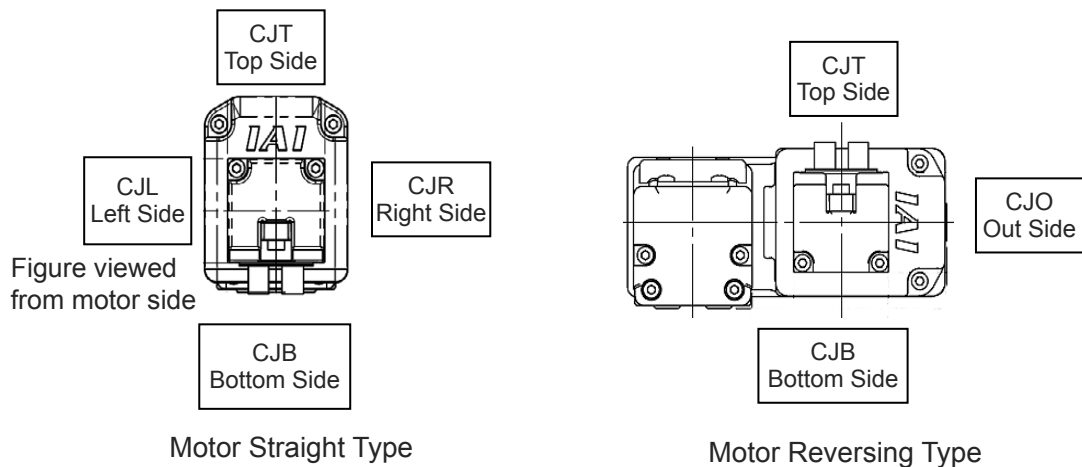

### High Precision Specifications (Model Code: HPR)

Standard positioning repeatability is  $\pm 0.01\text{mm}$ . When this option is specified, positioning repeatability will become  $\pm 0.005\text{mm}$ . It should be available to order only for lead length 20mm or less.

### Motor Reversed Direction (Model Code: ML, MR)

It is the code to indicate the direction of motor reversed when selecting the motor reversed type. ML shows reversed to left and MR to right.



### Reversed-home Specification (Model Code: NM)

The standard home position is on the motor side.

However, the opposite side specification is selected if the home position direction is reversed in accordance with equipment layout or assembly direction.

### **Slider Roller Specification (Model Code: SR)**

---

The structure of the slider in the standard type can be changed to the roller structure same as the one in the cleanroom type.

If it gets chosen to have the slider roller type, the appearance and dimensions of the slider cover should become the same as the cleanroom type.

### **Vacuum Joint Attachment Opposite Type (Model Code: VR)**

---

The vacuum joint should be attached on the left of the main unit in the view from the motor end in standard, which can be changed to the right (opposite) in option.

### **Double Slider Specification (Model Code: W)**

---

This is an option that adds a free slider that is not connected to the ball screw.

Doubling the slider makes it possible to increase the moment and the overhang load length.

\* Refer to " Double Slider (Option) (Page 1-28)" in "1.2 Specifications" for details.

### **Rear Attachment Plate (Model Code: RP)**

---

It is a bracket (plate) to affix the motor reversed type (SA4R) at the back to a device.

**Slider spacer (Model Code: SS)**

It is a spacer to set the top of the slider higher than the top of the motor cover.

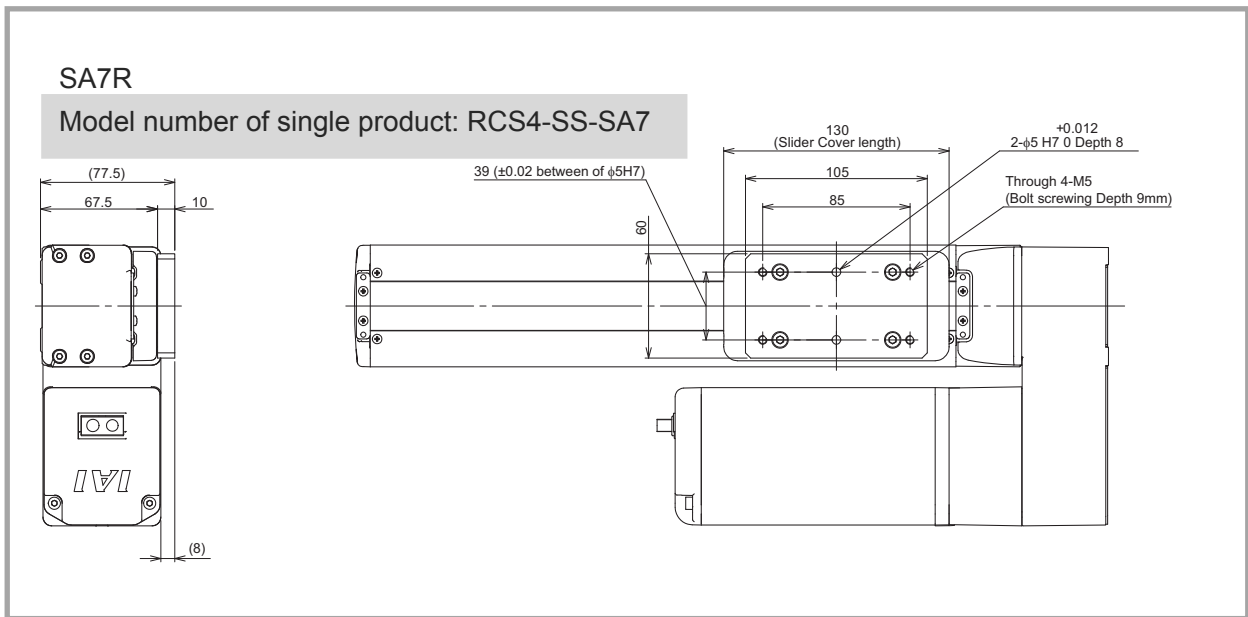
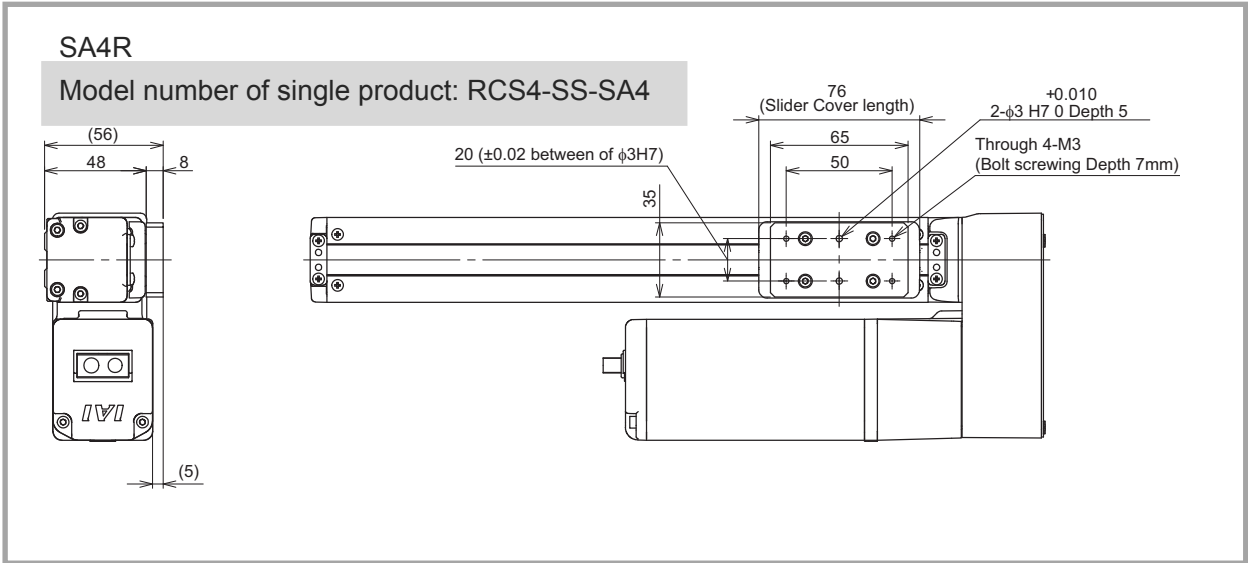

SA8R

Model number of single product: RCS4-SS-SA8

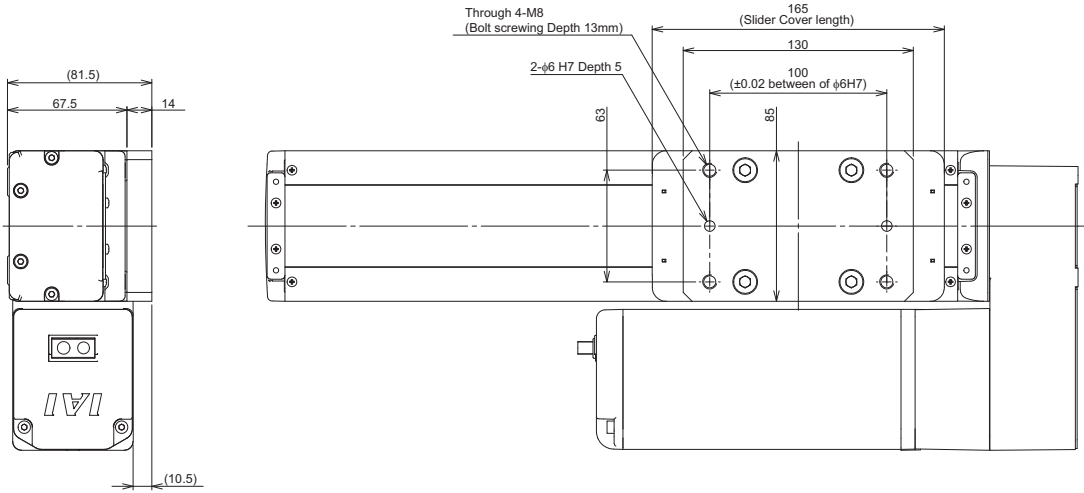

# 1.4 Accessories

## Motor Cable

**Model code: CB-RCC-MA□□□/ CB-RCC-MA□□□-RB**

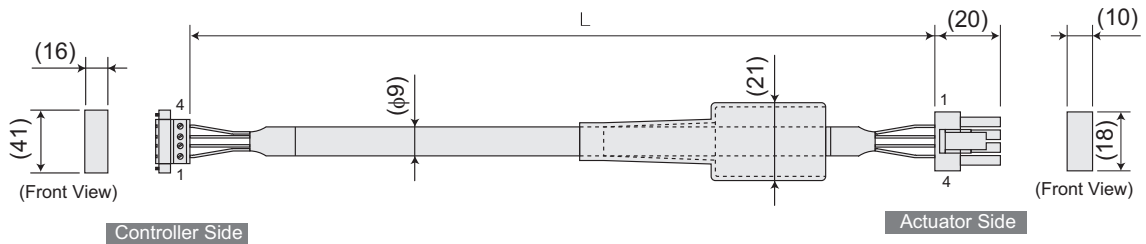

Minimum bending radius  $r = 51\text{mm}$  or more (for movable use)  
 \* It is only robot cable available to use inside the cable track

Wire Size	Color	Signal	No.	No.	Signal	Color	Wire Size
0.75sq	Green	PE	1	1	U	Red	0.75sq (Crimped)
	Red	U	2	2	V	White	
	White	V	3	3	W	Black	
	Black	W	4	4	PE	Green	

- The cable length should be 1m at minimum and 20m at maximum.  
Order can be make in unit of 1m long.
- An example for model codes is as shown below.
  - Cable length 1m → CB-RCC-MA010 (-RB)
  - Cable length 3m → CB-RCC-MA030 (-RB)
  - Cable length 10m → CB-RCC-MA100 (-RB)

**Encoder Cable**

**Model code: CB-X1-PA□□□**

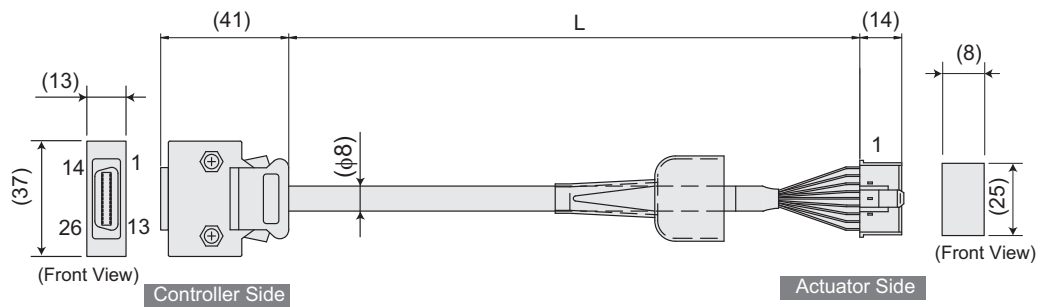

Minimum bending radius  $r = 44\text{mm}$  or more (for movable use)  
 \*Robot cable is standard for this model.

Wire Size	Color	Signal	No.
—	—	—	10
—	—	—	11
—	—	E24V	12
—	—	OV	13
—	—	LS	26
—	—	CREEP	25
—	—	OT	24
—	—	RSV	23
—	—	—	9
—	—	—	18
—	—	—	19
—	—	A+	1
—	—	A-	2
—	—	B+	3
—	—	B-	4
—	—	Z+	5
—	—	Z-	6
Orange	—	SRD+	7
Green	—	SRD-	8
Purple	—	BAT+	14
Gray	—	BAT-	15
Red	—	VCC	16
Black	—	GND	17
Blue	—	BKR-	20
Yellow	—	BKR+	21
—	—	—	22

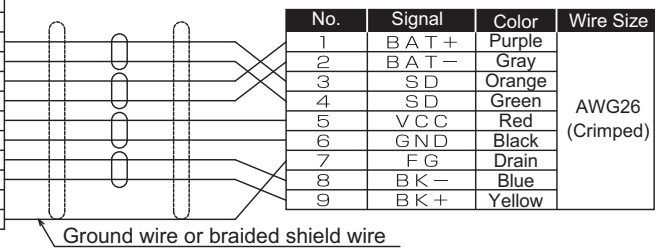

- The cable length should be 1m at minimum and 20m at maximum.  
 Order can be make in unit of 1m long.
- An example for model codes is as shown below.
  - Cable length **1m** → CB-X1-PA**010**
  - Cable length **3m** → CB-X1-PA**030**
  - Cable length **10m** → CB-X1-PA**100**





# ROBO Cylinder

---

# Chapter 2

## Installation

2.1	Precautions for transportation .....	2-1
2.2	Installation and storage/preservation environment .....	2-3
	Installation Environment .....	2-3
	Storage/preservation environment .....	2-4
2.3	How to Install .....	2-5
	Installation Orientation .....	2-5
	Precautions regarding stainless steel sheet .....	2-6
	Installation surface .....	2-7
	Installation of the Main Unit .....	2-8
	Mounting transported objects .....	2-16
	About Suction of the Cleanroom Type .....	2-19

## 2.1 Precautions for transportation

### [Handling the package]

- Do not damage or drop the package.

The package is not specially designed to withstand dropping or shock due to collision.

- Keep the unit in horizontal orientation for stationary positioning or transportation.
- Do not climb onto the package.
- Do not put anything that could deform the package on it.



**[Handling after unpacking]**

- Hold the base part when you carry the unit.
- Do not carry the unit by its motor cover or stainless steel sheet.
- Do not damage or drop the package during transportation.
- Do not apply excessive force to any part of the actuator.

→For the names of each part, refer to "Names of the Parts" on page Intro-11, 12.

**[Handling when assembled into machinery (system)]**

- Fix the slider so they would not accidentally move during transportation.
- If the actuator or any moving part is overhanging, fix it appropriately to avoid large wobbles due to external vibration.

When transporting without fixing the tip, do not apply impact of 0.3G or more.

- When suspending machinery (system) with ropes, be careful not to catch the rope on the actuator or cable.

## 2.2 Installation and storage/preservation environment

Usage is possible in environments of pollution degree 2 or equivalent.

Pollution degree 2: Environment in which generally only nonconductive pollution occurs, but temporary conductive pollution may occur due to condensation (IEC 60664-1)

### Installation Environment

The actuator should be installed in a location other than those specified below.

In general, the installation environment should be one in which an operator can work without protective gear.

- Where the actuator receives radiant heat from strong heat sources such as heat treatment furnaces
- Where the ambient temperature exceeds the range of 0 to 40°C
- Where the temperature changes rapidly and condensation occurs
- Where the relative humidity exceeds 85% RH
- Where the actuator receives direct sunlight
- Where the actuator is exposed to corrosive or combustible gases
- Where the ambient air contains a large amount of powder dust, salt or iron (at level exceeding what is normally expected in an assembly plant)
- Where the actuator is subject to splashed water, oil (including oil mist or cutting fluid) or chemical solutions
- Where the actuator receives impact or vibration
- Where the altitude is more than 2,000m

Also, provide sufficient work space for the following maintenance and inspection:

- Space to replenish grease
- Space to replace the motor

If the actuator is used in any of the following locations, provide sufficient shielding measures:

- Where noise generates due to static electricity, etc.
- Where the actuator is subject to a strong electric or magnetic field
- Where the actuator is subject to ultraviolet ray or radiation

## Storage/preservation environment

---

- For the storage and preservation environment, see the installation environment.  
However, give especial consideration to the prevention of condensation during long-term storage/preservation.
- Unless especially specified, desiccant is not included in the package at shipping.  
If the product is to be stored/preserved in an environment where condensation is anticipated, take condensation preventive measures.
- For short-term storage, it can be stored at 60°C or below.  
For storage of one month or more, make sure that the temperature does not exceed 50°C.
- The product should be placed horizontally for storage and preservation.  
If storing in the packaged condition, observe the conditions, if any, regarding storage orientation.

## 2.3 How to Install

### Installation Orientation Type: RCS4 –SA4/SA6/SA7/SA8

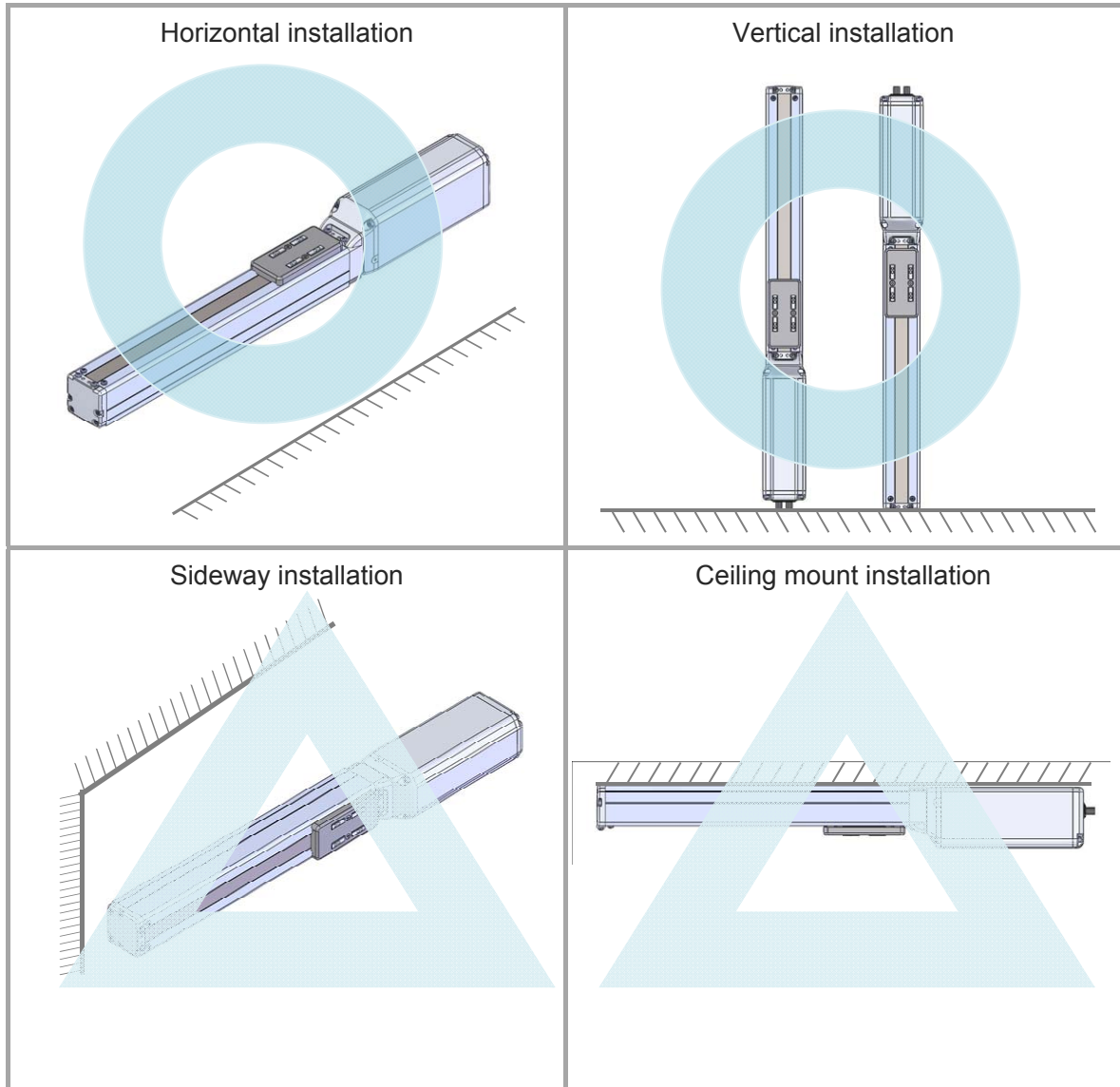

#### Caution

- When installing the unit vertically, keep the motor on top to the greatest extent possible.
- If the motor is installed on the bottom, the grease may separate due to long-term disuse, causing the base oil to flow into the motor part. The controller and motor/encoder may break down due to the entry of the base oil.

## ○ Precautions regarding stainless steel sheet

---

- During installation and transport, do not grasp or press on the stainless steel sheet. Otherwise, this may lead to stainless steel sheet damage.
- Although lateral or ceiling installation is possible, it may cause slackness or misalignment of the stainless steel sheet. Continued usage in this orientation may lead to damage to the stainless steel sheet.
- Adjust the stainless steel sheet if slackness or misalignment occurs.
- Keep adhesive, paint, and other viscous material off the stainless steel sheet. Such material adhering to the stainless steel sheet can lead to defective slider operation or sheet damage. Avoid installation in environments of this kind, or take safety measures to prevent adhesion.

### Installation surface

- The body mounting surface should be a machined surface or a plane with similar accuracy, with flatness within 0.05mm/m.
  - The mounting frame should have a structure rigid enough to prevent the generation of vibration, etc.
  - Also consider enough space necessary for maintenance work such as actuator replacement and inspection.
  - The bottom surface and both side surfaces of the body base serve as the reference surfaces for slider running accuracy.
- Use these surfaces as the reference surfaces for mounting when running accuracy is required.

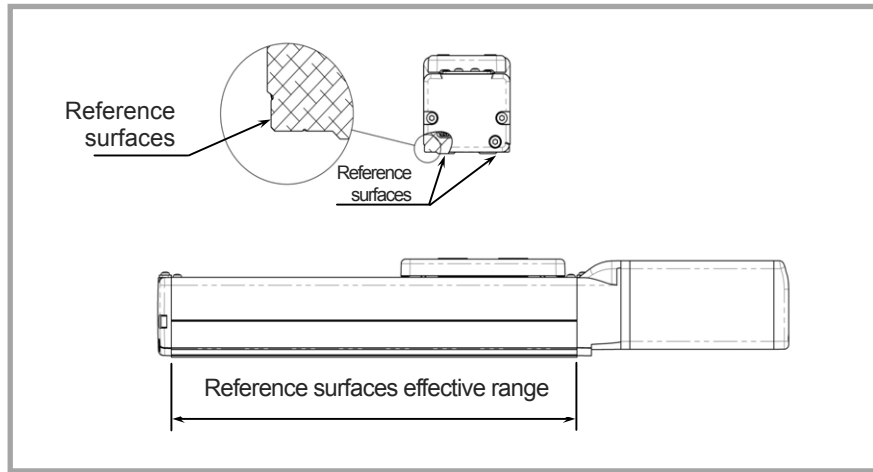

When mounting using the side reference surface, machine the installation surface according to the figure below.

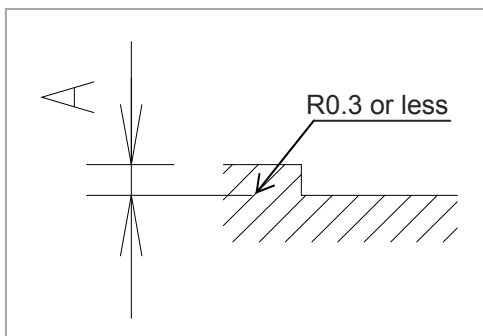

A dimension	
SA4	
SA6	2 to 4mm
SA7	
SA8	3 to 5mm



## Installation of the Main Unit

### [When using the tapped holes on the bottom of the base]

The unit has a tapped holes at the bottom of the base for mounting. It can be affixed at the back using the tapped holes.

→For details regarding the position and dimensions, Refer to "Chapter 5 External Dimensions".

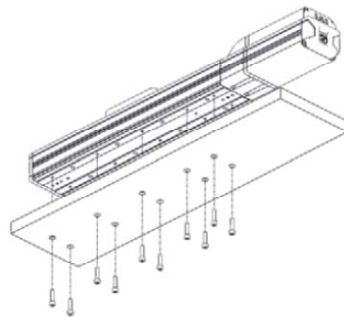

#### Dimensions for Tapped Hole Positions

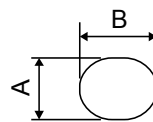
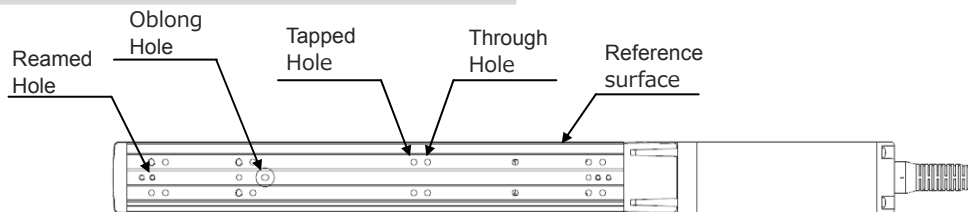

Oblong Hole

Model Name	Tapped Hole Size	Tapped Holes Depth	Reamed Hole (mm)	Oblong Hole
SA4C SA4R	M4	Through (screwing depth should be 6mm or less)	φ3H7 Depth 4	A: $3^{+0.010}_0$ B: 4 Depth 4mm or less
SA6C SA6R	M5	Through (screwing depth should be 10mm or less)	φ4H7 Depth 5.5	A: $4^{+0.012}_0$ B: 5 Depth 5.5mm or less
SA7C SA7R	M5	Through (screwing depth should be 10mm or less)	φ4H7 Depth 6	A: $4^{+0.012}_0$ B: 5 Depth 6mm or less
SA8C SA8R	M6	Through (screwing depth should be 12mm or less)	φ6H7 Depth 6.5	A: $6^{+0.012}_0$ B: 7 Depth 6.5mm or less

## [Tightening Torque]

Model Name	Tapped Hole	Tightening Torque	
		In the case that steel is used for the bolt seating surface:	Reamed Hole (mm) In the case that aluminum is used for the bolt seating surface:
SA4C SA4R	M4	3.59N•m (0.37kgf•m)	1.76N•m (0.18kgf•m)
SA6C SA6R	M5	7.27N•m (0.74kgf•m)	3.42N•m (0.35kgf•m)
SA7C SA7R	M5	7.27N•m (0.74kgf•m)	3.42N•m (0.35kgf•m)
SA8C SA8R	M6	12.3N•m (1.25kgf•m)	5.4N•m (0.55kgf•m)

**Notice**

- The use of high-strength bolts of ISO-10.9 or higher is recommended.
- Make sure the internal thread and bolt effective engagement length is approximately 1.8 times the nominal diameter or more.

### [Using the Through Holes on the Top of the Base]

As SA4, SA6 and SA7 are equipped with through holes on the base for purpose of installation from the top, it is available to screw in from the top side.

Detach the side covers on the sides when installing.

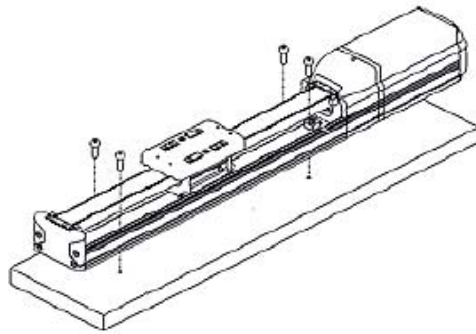

For mounting bolts, use hexagonal socket head bolts indicated in the following table depending on the platform material.

Model Name	Through Hole	Mounting Bolt	Tightening Torque
SA4C SA4R	φ3.4 drilled hole, 6.5 counter boring depth 3.5	M3	0.83N•m (0.085kgf•m)
SA6C SA6R	φ4.5 drilled hole, 8 counter boring depth 4.5	M4	1.76N•m (0.18kgf•m)
SA7C SA7R	φ6 drilled hole, 9.5 counter boring depth 5.5	M5	3.42N•m (0.35kgf•m)

### Detaching Side Cover

- Remove 4 attachment screws (+) with a Philips screwdriver.
- The slider cannot be driven only with ROBO Cylinder itself if it is equipped with a brake. Connect a controller and have JOG operation to move the slider to perform installation.



### Caution

- Attempt not to drop the bolts, tools, etc. on the stainless steel sheet when tightening the bolts. Please avoid making a dent mark or scratches.
- For the side-mounted specification models of SA4R, SA6R, and SA7R, the side cover and motor cover interfere each other so that they cannot be removed as they are. Remove the motor cover and detach the side cover.  
[For removing direction of the motor cover, refer to Motor Replacement in “4.6 How to replace components”]

---

### Notice

- The use of high-strength bolts of ISO-10.9 or higher is recommended.
  - Make sure the internal thread and bolt effective engagement length is approximately 1.8 times the nominal diameter or more.
-

### [When Using Attachment Holes on Bracket in Motor Reversing Type]

As there are tapped holes on the reversing bracket, it is available to screw in from the back. It should be an option (Model: RP) for SA4R.

- For SA4R (Option)

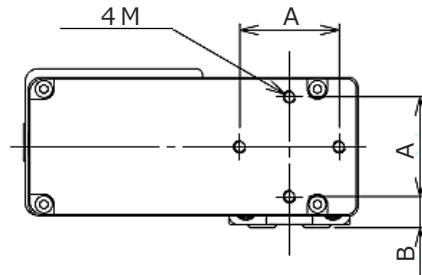

- For SA6R

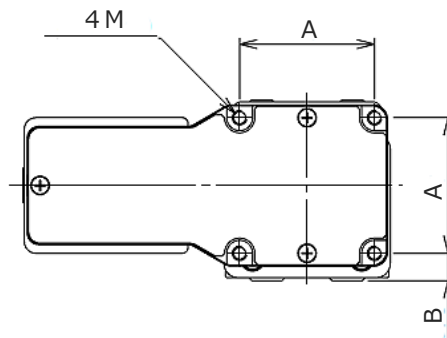

Model Name	A	B	Attachment Hole Diameter	Attachment Hole Depth	Tightening Torque
SA4R	32	10	M 4	8mm	1.76N·m (0.18kgf·m)
SA6R	47	9.5	M 5	10mm	3.42N·m (0.35kgf·m)

- For SA7R and SA8R

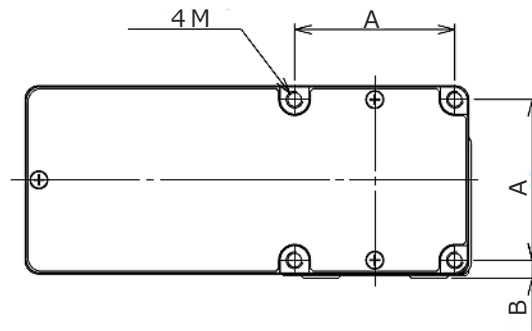

Model Name	A	B	Attachment Hole Diameter	Attachment Hole Depth	Tightening Torque
SA7R	58	6.5	M6	12mm	5.4N·m (0.55kgf·m)
SA8R	58	8	M6	12mm	5.4N·m (0.55kgf·m)

### Notice

- The use of high-strength bolts of ISO-10.9 or higher is recommended.
- Make sure the internal thread and bolt effective engagement length is approximately 1.8 times the nominal diameter or more.

**[Precautions when using reversing brackets]**

- Availability of installation for each installation posture is as shown below:

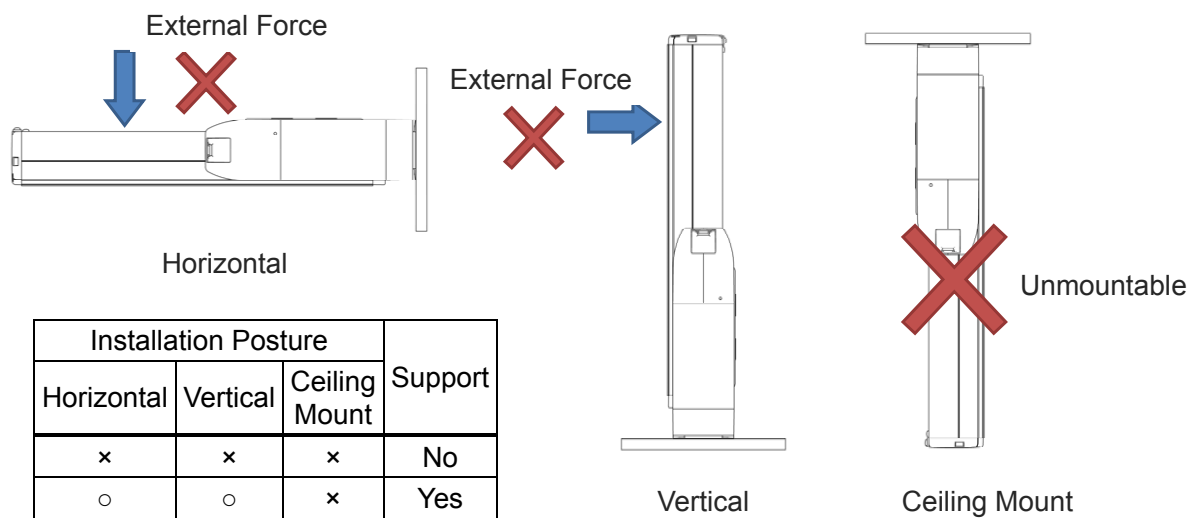
**Caution**

- Do not attempt to affix the unit only with the tapped holes on the side-mounted bracket.
- Do not apply external force to the actuator body after installation.
- External force may cause malfunctions or damage to parts.

**[Precautions for horizontal mounting using reversing brackets]**

- Prepare a support block for the body, as shown in the figure below.

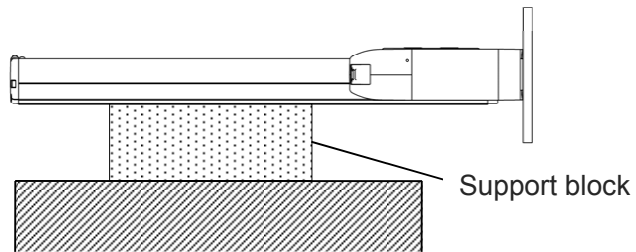



## Mounting transported objects

[For SA4C/R, SA6C/R, SA7C/R]

- Use the tapped mounting holes on the top surface of the slider to fix transported objects.
- There are 4 reamed holes on the top surface of the slider.  
Use these reamed holes if repeated attaching and detaching is required.
- If fine-tuning of perpendicularity, etc. is required, use one of the reamed holes for this adjustment.
- Refer to the figure below for the screw-in depth and reamed hole depth.

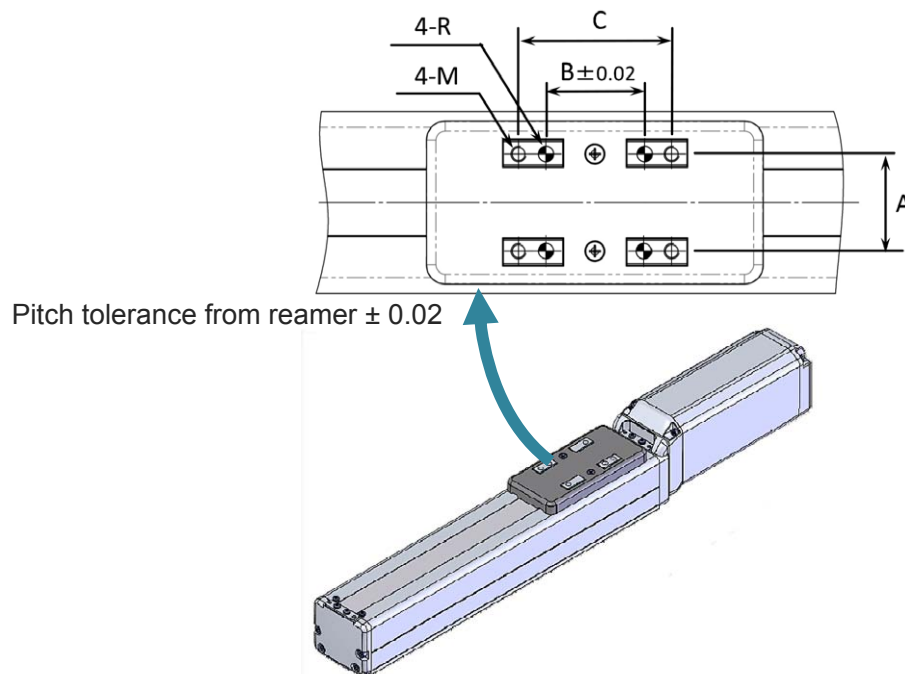

Model Name	A	B	C	Reamed Hole	Tapped Hole M	Mounting Bolt	
						Bolt Nominal Diameter	Tightening Torque
SA4C, SA4R	20	24	32	$\phi 3H7$ Depth6	M3Depth7	M3	$0.83N \cdot m (0.085Kgf \cdot m)$
SA6C, SA6R	31	32	50	$\phi 5H7$ Depth6	M5Depth10	M5	$3.42N \cdot m (0.35Kgf \cdot m)$
SA7C, SA7R	39	42	65	$\phi 5H7$ Depth10	M5Depth10	M5	$3.42N \cdot m (0.35Kgf \cdot m)$

**[For SA8C/R]**

- Use the tapped mounting holes on the top surface of the slider to fix transported objects.
- There are 2 reamed holes on the top surface of the slider.  
Use these reamed holes if repeated attaching and detaching is required.
- If fine-tuning of perpendicularity, etc. is required, use one of the reamed holes for this adjustment.
- Refer to the figure below for the screw-in depth and reamed hole depth.

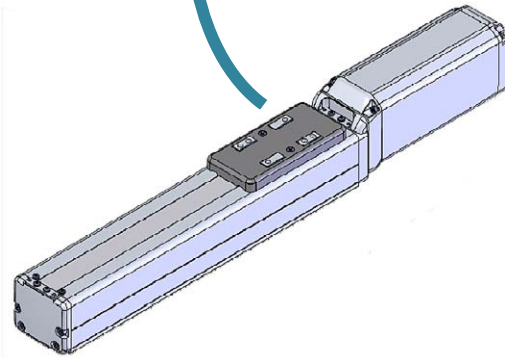
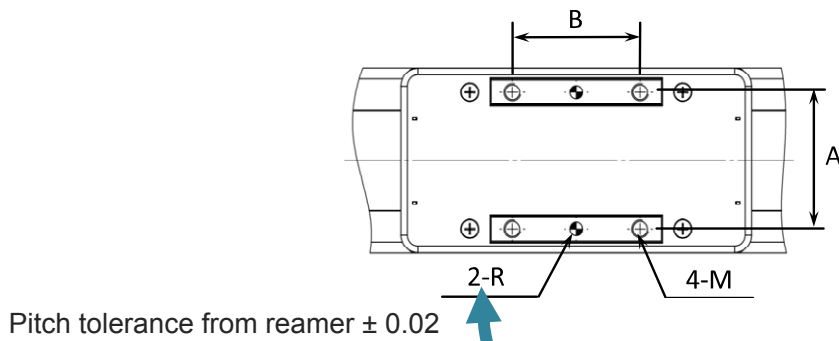

Model Name	A	B	C	Reamed Hole	Tapped Hole M	Mounting Bolt	
						Bolt Nominal Diameter	Tightening Torque
SA8C, SA8R	63	60		$\phi 6H7$ Depth10	M8 Through (screwing depth should be 12mm max.)	M8	11.5N•m(1.17Kgf•m)



---

### Caution

- Be careful with regard to the length of the mounting bolt and positioning pin.
  - The use of screw-in depth greater than that of the tapped or reamed mounting holes may damage the tapped hole or reduce the mounting strength of the transported object, leading to decreased accuracy or unexpected accidents.
- 

---

### Notice

- The mounting bolts are to be prepared by the customer.
  - The use of high-strength bolts of ISO-10.9 or higher is recommended.
-

## About Suction of the Cleanroom Type

- Cleanroom type actuators are able to exert performance corresponding to cleanroom class 10 (0.1µm, Fed.Std.209D) and class 2.5 equivalent (ISO 14644-1) by aspirating air from the vacuum joint.  
The guidelines of the suction amounts for the rated speeds of each model are shown in the following table.

[Suction amount guideline]

Single slider specification

Model Number	Lead [mm]	Suction Amount NI/min (L/min)
SA4C	16	60(65)
	10	40(43)
	5	20(22)
	2.5	10(11)
SA6C	20	100(108)
	12	70(76)
	6	30(32)
	3	15(16)
SA7C	24	90(97)
	16	70(76)
	8	40(43)
	4	30(32)
SA8C	20	160(173)
	10	80(86)
	5	40(43)

[Suction amount guideline]

Double slider specification (option model W)

Model Number	Lead [mm]	Suction Amount NI/min (L/min)
SA4C	10	60(65)
	5	30(32)
	2.5	20(22)
SA6C	12	110(119)
	6	60(65)
	3	35(38)
SA7C	16	100(108)
	8	50(54)
	4	40(43)
SA8C	10	120(130)
	5	50(54)

## Notice

- Please perform suction of air from the two vacuum joints located on the sides of the actuator according to the suction amounts (total amount of the two locations) shown in the table below.  
Also, please manage the joints so that the suction amounts of the two locations are equivalent.
- Please use the actuator in a state in which all of the base attachment holes on the bottom of the actuator are covered. When there is a hole that passes through the actuator, the level of cleanliness decreases.



**ROBO Cylinder**

---

**Chapter 3**

**Connecting with  
the Controller**

3.1 Connecting with the Controller ..... 3-1

## 3.1 Connecting with the Controller

As the connection cable for the controller and the actuator, use the IAI-dedicated connection cable.

Please consult with IAI if you require a different kind of cable than the one supplied.

- If the dedicated connection cable cannot be secured, reduce the load on the cable by allowing it to deflect only by the weight of the cable or wire it in a self-standing cable hose, etc., having a large radius.
- Do not cut and reconnect the dedicated connection cable for extension or shorten the cable.
- Do not pull on the dedicated connection cable or bend it forcibly.
- The actuator cable coming out of the motor unit is not meant to be bent. Fix the cable so it would not be bent repeatedly

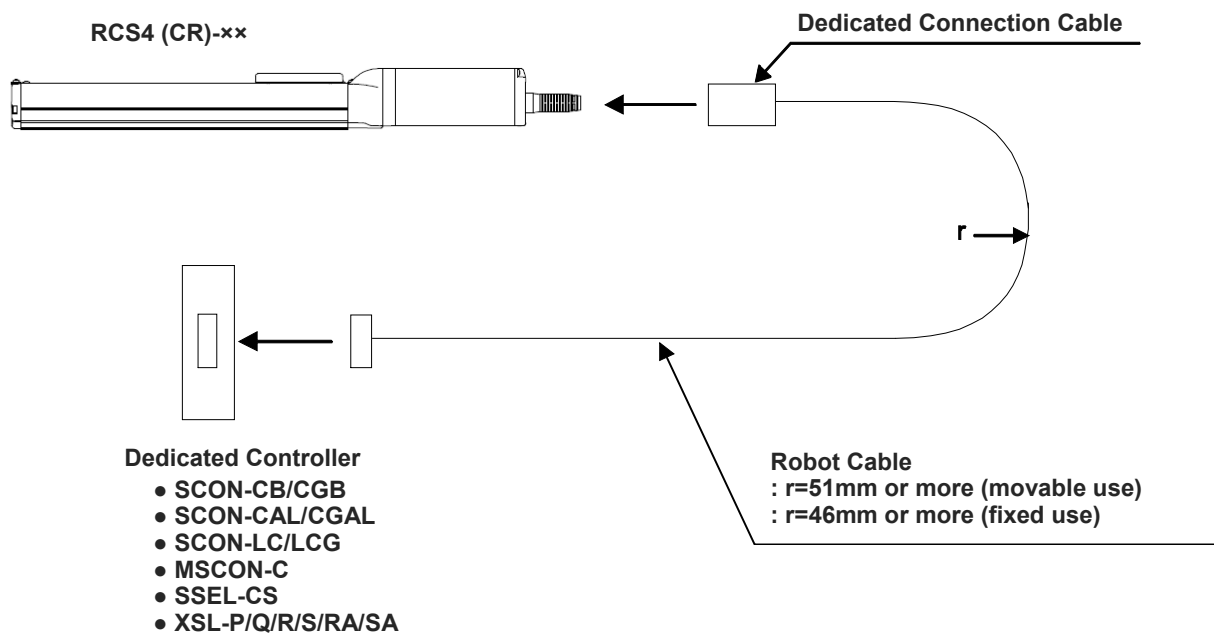

**Dedicated Cable**

- Motor Cables:
- Motor Robot Cables:
- Encoder Robot Cables:

\* □□□ represents the cable length.  
e.g.) 080 = 8m

- CB-RCC-MA□□□
- CB-RCC-MA□□□-RB
- CB-X1 -PA□□□

The longest corresponds to 20m.







## Caution

- For wiring, please follow the warnings stated below. When constructing a system as the machinery equipment, pay attention to the wiring and connection of each cable so they are conducted properly. Not following them may cause not only a malfunction such as cable breakage or connection failure, or an operation error, but also electric shock or electric leakage, or may even cause a fire.
- Use dedicated cables of IAI indicated in this instruction manual. Contact us if you wish to have a change to the specifications of the dedicated cables.
- Make sure to turn the power off in the process of power line or cable connection or disconnection.
- Do not attempt to cut a dedicated cable with connectors on both ends to extend, shorten or re-joint it.
- Hold the dedicated cable to avoid mechanical force being applied to the terminals and connectors.
- Use a cable pipe or duct to have an appropriate protection when there is a possibility of mechanical damage on a dedicated cable.
- In case a dedicated cable is to be used at a moving part, make sure to lay out the cable without applying any force to pull the connector or extreme bend on the cable. Do not attempt to use the cable with a bending radius below the allowable value.
- Make certain that the connectors are plugged properly. Insufficient connection may cause an operation error, thus it is extremely risky.
- Do not lay out the cables to where the machine runs over them.
- Pay attention to the cable layout so it would not hit peripherals during an operation. In case it does, have an appropriate protection such as a cable track.
- When a cable is used hanging on the ceiling, prevent an environment that the cable swings with acceleration or wind velocity.
- Make sure there is not too much friction inside the cable storage equipment.
- Do not apply radiated heat to power line or cables.

 **Caution**

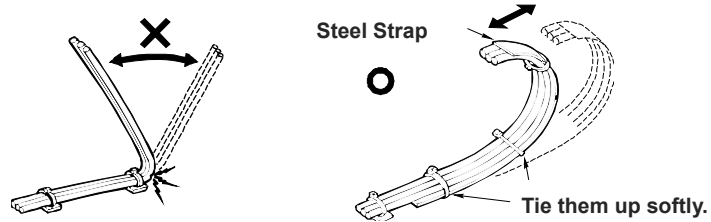
 Have a sufficient radius for bending, and avoid a bend concentrating on one point.



 Do not let the cable bend, kink or twist.

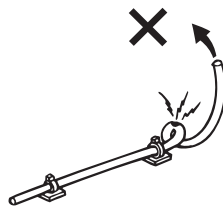

 Do not pull the cable with a strong force.

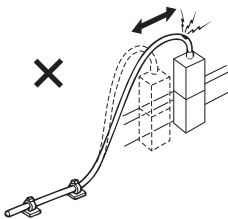

 Pay attention not to concentrate the twisting force to one point on a cable.

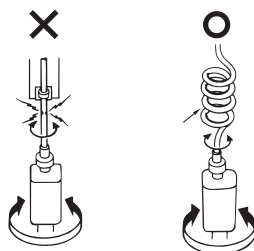

**Caution**

- Do not pinch, drop a heavy object onto or cut the cable.

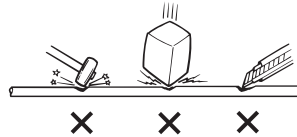

- When a cable is fastened to affix, make sure to have an appropriate force and do not tighten too much.

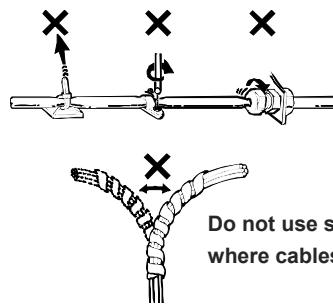

- PIO line, communication line, power and driving lines are to be put separately from each other and do not tie them together. Arrange so that such lines are independently routed in the duct.

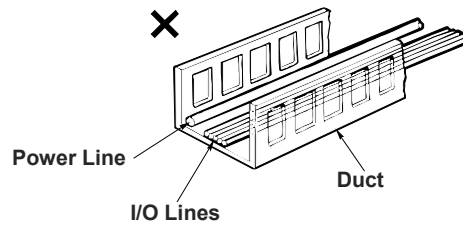

 **Caution**

Follow the instructions below when using a cable track.

- If there is an indication to the cable for the space factor in a cable track, refer to the wiring instruction given by the supplier when storing the cable in the cable track.
- Avoid the cables to get twined or twisted in the cable track, and also to have the cables move freely and do not tie them up. (Avoid tension being applied when the cables are bent.)
- Do not pile up cables. It may cause faster abrasion of the sheaths or cable breakage.

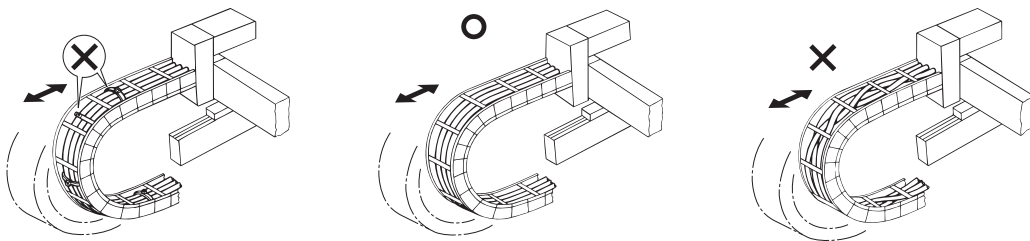

# ROBO Cylinder

---

# Chapter 4

## Maintenance and Inspection

4.1	Precautions for maintenance and inspection work	4-1
4.2	Inspection Items and Schedule	4-3
	Slider type	4-3
	Grease supply timing (Guideline)	4-3
4.3	Visual inspection items	4-4
	External visual inspection	4-4
	Internal visual inspection	4-5
4.4	Cleaning	4-7
	External cleaning	4-7
	Internal Cleaning	4-7
4.5	Greasing method	4-8
	Grease used	4-8
	Greasing method	4-10
4.6	How to replace components	4-13
	Stainless steel sheet replacement/adjustment	4-13
	Belt replacement/adjustment	4-19
	Motor Replacement	4-24

## 4.1 Precautions for maintenance and inspection work

Make sure to read the following precautions before conducting any maintenance or inspection work.



### Caution

- Do not climb on or put anything on the actuator. Otherwise, this may lead to accidental falling, injury or damage to the product due to falling objects, product loss of function or performance degradation, or shortening of product life.
- Before releasing the brake, make sure to check there is nothing that will interfere with moving parts within the operation range.
- The slider may fall, possibly injuring the operator or people nearby and damaging the actuator, workpiece or equipment.



### Caution

- Check that the power to the actuator is OFF before conducting any maintenance or inspections.
- Be careful not to lose the cover or any removed screws. Be sure to return the product to the original condition after maintenance and inspection work. Mounting in an incomplete state may cause injuries or damage to the product.
- Do not modify, disassemble/assemble, or use maintenance parts not specified on your own discretion under any circumstances.



### Caution

The grease film may run out if the actuator performs return operation continuously over a distance of 30mm or less. As a guideline, every 5,000 to 10,000 cycles, have approximately 5 cycles of return operation over a 50mm distance or more to regenerate the oil film.

The ball screw or guide may be damaged if the oil film runs out.

---

### Notice

- First, be sure to wipe off the old grease, and then supply new grease.
- The degradation speed of grease may differ depending on the operating environment (temperature, humidity and ambient atmosphere).

It is recommended to shorten the grease supply period if the actuator is used under poor environmental conditions such as high temperatures, high humidity or dusty atmospheres.

- Also, it is recommended to improve the environmental conditions in case the grease changes color notably due to poor operating conditions.
- Base oil may separate from the grease due to the mounting orientation or operating conditions.

Base oil may also leak from the inside of the actuator to the exterior through gaps. Check visually for oil drips when supplying grease.

- An actuator stored for 6 months or more may suffer from grease degradation. Supply grease before the start of use.

→For details, refer to "4.5 Greasing method".

---

## 4.2 Inspection Items and Schedule

Follow the maintenance inspection schedule below.

It is assumed that the equipment is operating 8 hours per day.

If the equipment is running continuously night and day or otherwise running at a high operating rate, inspect more often as needed.

### Slider type

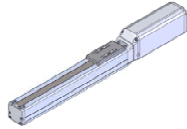

\*Stainless steel sheet life guideline: 5,000km

Inspection period	External inspection	Internal inspection	Greasing	
			Ball screw	Guide
Start of work inspection	○	-	-	-
1-month inspection	○	-	-	-
3-month inspection	-	-	○	○
3-month inspection on	-	-	Grease supply timing (Guideline) dependent	
6-month inspection	○	○		
Every 6 months thereafter	○	○		

### Grease supply timing (Guideline)

Maximum operating speed [mm/s]	Grease supply timing (Guideline)	
	Operation distance	Months
0 to 750 or less	1,250km	12 months
750 to 1500 or less	2,500km	
1500 to 2200	5,000km	



## 4.3 Visual inspection items

Refer to "4.6 How to replace components" for detailed information about specific component replacement and adjustment methods.

### External visual inspection

Inspection items	Maintenance work
<b>Is abnormal noise or vibration generated?</b>	Take an action by referring to "Troubleshooting in Controller Instruction Manual".
<b>Are actuator mounting bolts loose?</b>	Tighten them further.
<b>Is the cable scratched?</b>	Replace if the damage is severe.
<b>Is the connector loose?</b>	Re-insert correctly.
<b>Is grease dripping out? (especially if vertically mounted)</b>	Clean up any drips. Replenish the grease.
<b>Is the stainless steel sheet scratched?</b>	Replace the stainless steel sheet.
<b>Is the stainless steel sheet misaligned or slack?</b>	Adjust the alignment and hang.

Refer to "4.6 How to replace components" for detailed information about specific component replacement and adjustment methods.

### Internal visual inspection

Inspection items	Maintenance work
<b>Backlash/play or wear debris found?</b>	The ball screw guide may be damaged. Contact IAI.
<b>Has foreign matter penetrated inside?</b>	Remove the foreign matter, clean, and inspect the interior for any damage.
<b>Is the ball screw or guide grease not lubricating well? (Even if the grease is brown, lubrication is adequate if the running surface is shiny )</b>	Wipe away the old grease, then replenish with new grease.
<b>Is dust or foreign matter adhered to the ball screw or guide?</b>	Replenish with new grease after cleaning.

#### Internal inspection method

- 1) Loosen the screws on the side cover and detach the side cover.
- 2) Check inside.
- 3) After finishing the inspection, assemble back in the reverse order. If you touch the edge of the stainless steel sheet in the attaching the side cover process, the sheet may get damaged or wavy which result in shortening life or earlier wear-out. To avoid touching the edge of the sheet, insert a spacer (approximately 0.1 to 0.2mm) between the sheet and cover to push up the sheet, and then push in the cover. When affixing the side cover, tighten the screws with the tightening torque described below.

Screw Diameter	Tightening Torque
M3	41.4N•cm

- 4) Make sure that the slider and the side cover do not interfere, moving the slider backwards and forwards between the strokes.



### Caution

Do not damage the stainless steel sheet by bending it forcefully during internal inspection.

Do not tug on the stainless steel sheet or in any way attempt to reposition it.

Change in the attached condition may cause the sheet to be mounted unevenly or impact the product life.

Keep in mind that the edges of the stainless steel sheet can cause injuries.

Always wear gloves when working on it.

---

## 4.4 Cleaning

### External cleaning

---

- Clean exterior surfaces as necessary.
- Use a soft cloth to wipe away dirt and buildup.
- Do not blow too hard with compressed air as it may cause dust to get in through the gaps.
- Do not use oil-based solvents as they can harm lacquered and painted surfaces.
- To remove severe buildup, wipe gently with a soft cloth soaked in a neutral detergent or alcohol.

### Internal Cleaning

---

- Use a soft cloth to wipe away dirt and buildup.
- Do not blow too hard with compressed air as it may cause dust to get in through the gaps.
- Do not use oil-based solvents, neutral detergent or alcohol.

## 4.5 Greasing method

### [1] Grease used: Use an equivalent product

◎ Standard Type: Except for Lead 30 in SA6, Lead 36 in SA7 or Lead 48 in SA8

Application location	During maintenance (recommended product)	Default (reference)
Ball screw	Kyodo Yushi/Multemp LRL No.3	Kyodo Yushi/Multemp LRL No.3
Guide		



### Caution

- Never use fluorine-based grease and urea-based grease. Mixing with lithium-based grease not only reduces the performance of the grease, it may even cause damage to the actuator.

◎ Standard Type: Lead 30 in SA6, Lead 36 in SA7 and Lead 48 in SA8

Application location	During maintenance (recommended product)	Default (reference)
Ball screw	Kyodo Yushi/Multemp ET-R No.2	Kyodo Yushi/Multemp ET-R No.2
Guide		



### Caution

- Never use lithium-based grease and fluorine-based grease. Mixing with urea-based grease not only reduces the performance of the grease, it may even cause damage to the actuator.

### ◎ Cleanroom Type

<b>Application location</b>	<b>During maintenance (recommended product)</b>	Default (reference)
Ball screw	Kuroda Precision Industries/C grease	Kuroda Precision Industries/C grease
Guide		



### Caution

- For grease to be used with an actuator that has a cleanroom setting, please use a type of grease that emits a low amount of dust and is described for cleanroom use.  
When standard grease is used, dust may be emitted.
  - Never use lithium-based grease and fluorine-based grease.  
Mixing with urea-based grease not only reduces the performance of the grease, it may even cause damage to the actuator.
-

**[2] Greasing method:** Ball screw/guide (supply to both through grease fitting)**Greasing method**

- 1) Remove the screw and detach the side cover on either side, right or left.  
The grease nipple will appear.  
(Note) When the side cover on the other side has been detached, the other grease nipple also appears.

Side Cover  
Attachment Screws

Opposite Side

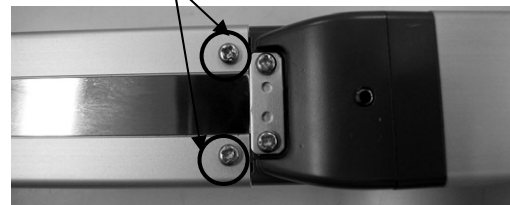
Side Cover  
Attachment Screws

Motor Side



Side Cover

After removal of the side cover on either side

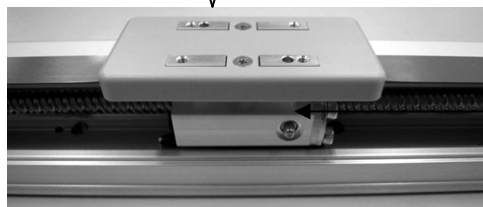
Grease Nipple  
There is one  
on the other side.

- 2) Supply grease from the grease nipple on either side, using the grease gun.  
 Wipe off the grease before supplying new in case it is extremely dirty.  
 (Note) Grease can also be applied from the grease nipple on the other side.  
 When grease is applied from the grease nipple on either side, grease is supplied to the ball screw and the guides on both sides.

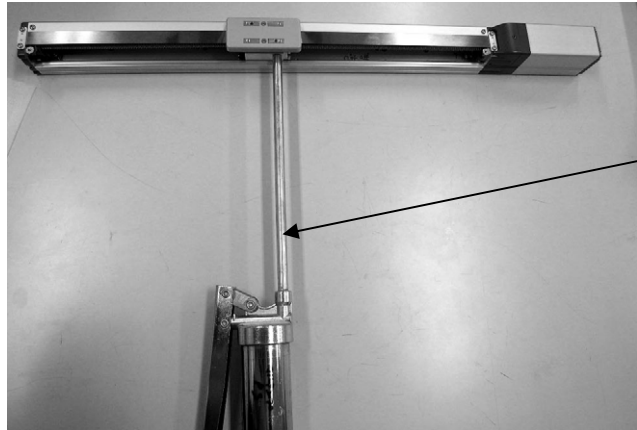

Grease Gun

(Note) Make sure to use a grease gun that is applicable for the grease nipple inlet diameter shown below.

Grease Nipple Diameter
φ3.5

Grease Gun	Nozzle	Supplier of nozzle
Grease gun of mounting screw R1/8 (Example) GC-57K (Yamada Corporation)	NZ3	NSK

Model Name	Amount of Grease Supply (Reference)
SA4	0.5cc to 1.0cc
SA6	1.5cc to 2.0cc
SA7	2.0cc to 2.5cc
SA8	3.5cc to 4.0cc

Move the slider back and forth in the stroke range after supplying grease so it spreads out evenly in the area.

- Confirm that the ball tracks on the ball screw and guide look glossy with oil of grease. Supply grease again if it is not spread enough.
- Wipe off excess grease.



**Caution**

Supplying too much grease may increase sliding resistance and load to the motor, resulting in a drop of performance.

Also, excess grease on the ball screw may be splashed around in the ambience.



- 3) Attach the side covers after grease supply is finished.  
If you touch the edge of the stainless steel sheet in the attaching process, the sheet may get damaged or wavy which result in shortening life or earlier wear-out.  
To avoid touching the edge of the sheet, insert a spacer (approximately 0.1 to 0.2mm) between the sheet and cover to push up the sheet, and then push in the cover.

When affixing the side cover, tighten the screws with the tightening torque described below.

Screw Diameter	Tightening Torque
M3	41.4N•cm

- 4) Make sure that the slider and the side cover do not interfere, moving the slider backwards and forwards between the strokes.



### Caution

- Do not damage the stainless steel sheet by bending it forcefully during work.
- Keep in mind that the edges of the stainless steel sheet can cause injuries. Always wear gloves when working on it.
- The front bracket is supporting the ball screw. Do not detach it.  
If the front bracket loses its tuned condition, it may cause an increase of driving resistance, shortened life of each component or abnormal noise due to the center of the axis being off the right position.
- In case the grease got into your eye, wash it with clean water for 15 minutes and immediately go see the doctor to get appropriate care.
- After finishing the grease supply work, wash your hands carefully with water and soap to rinse the grease OFF.

## 4.6 How to replace components

### Stainless steel sheet replacement/adjustment

#### Preparation

1) Items required for replacing the stainless steel sheet

- Replacement stainless steel sheet
- Phillips screwdriver
- Scale

#### Names of the Parts

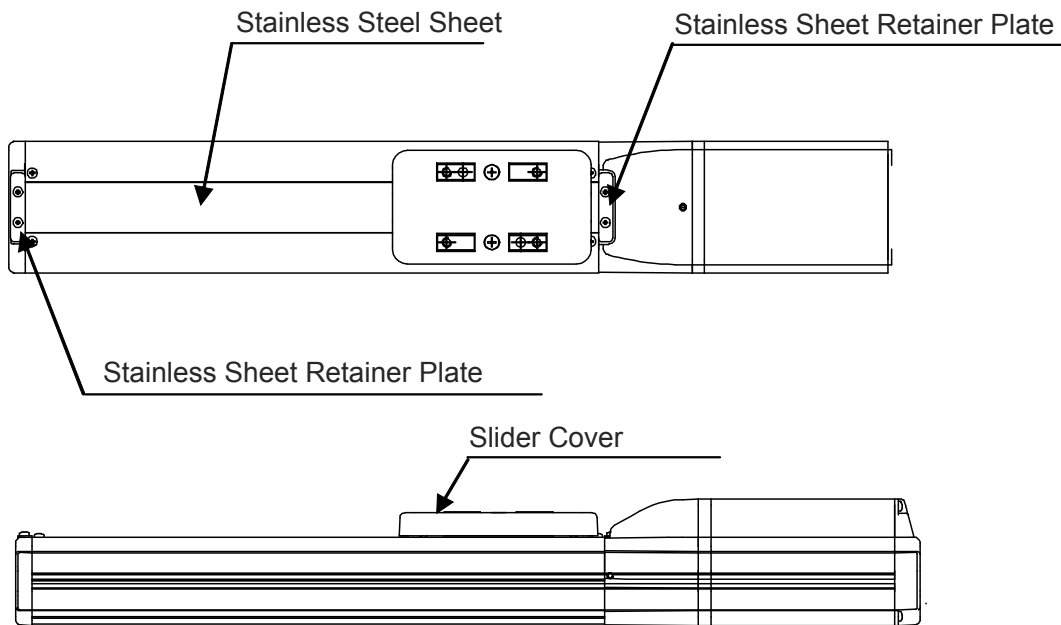

#### Caution

Degradation and wear-out of the stainless steel sheet relies on its tension of attachment. If the stainless steel sheet is pulled with a huge force and the gap between the sheet and the slider cover is large, there is a risk of metal fatigue.

On the other hand, if the tensile strength is too low, the stainless steel sheet would interfere with the back side of the slider cover and make dust to be generated.

Have a replacement and tuning in (1) Procedure 1 for SA7, SA8.

For SA4, SA6 have a replacement and tuning in either (1) Procedure 1 or (2) Procedure 2.

### Stainless steel sheet replacement method Procedure 1

- 1) Remove the screws (4 places) holding the stainless steel sheet and stainless steel sheet retainer plates (2 pieces) with using a Phillips screwdriver.
- 2) Pull the old stainless steel sheet till in front of the slider.  
Make sure not to pull it out completely off the slider.



Pull it till in front of the slider.

In front of Slider

- 3) Join a new stainless steel sheet to the old one with using cellophane tape.

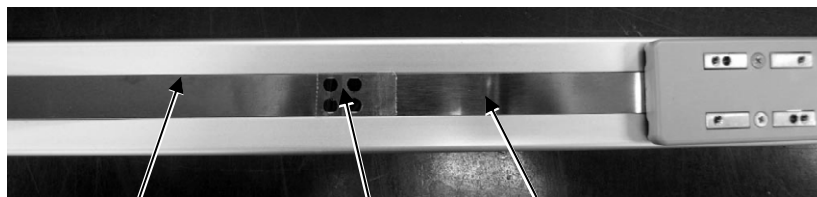

New stainless steel sheet

Join with cellophane tape

Old stainless steel sheet

- 4) Pull the old stainless steel sheet so the new one goes through below the slider. Pull it till the new stainless steel sheet comes to the edge of the actuator.

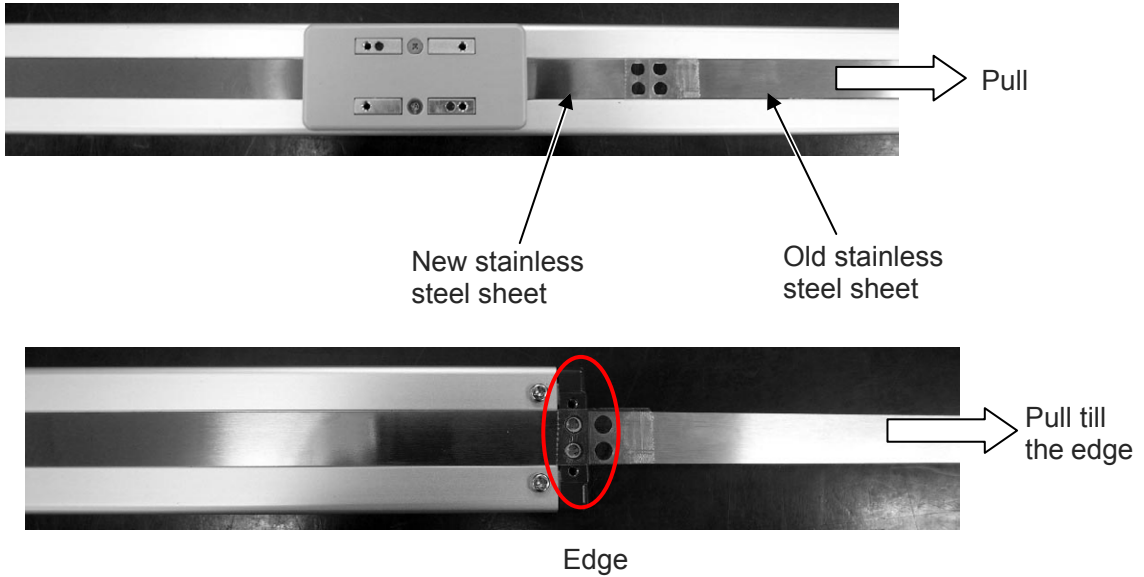

- 5) Remove the old stainless steel sheet.

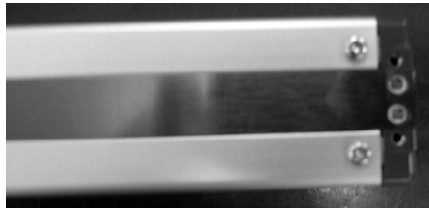

- 6) Fix the two stainless steel sheet retainer plates using the screws (four locations). Use a Phillips screwdriver to attach it.

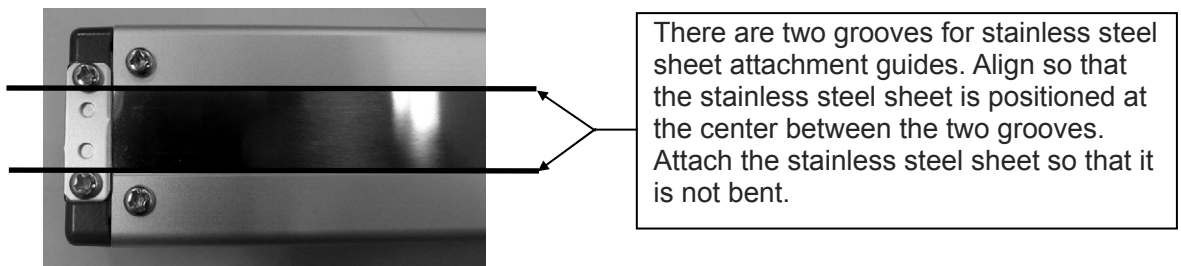

Tightening Torque
41.4N•cm

- 7) After the stainless steel sheet retainer plates have been fixed, move the slider from one side to the other side (full stroke) with your hand to check that there is no rise or slackness in the stainless steel sheet. If there is any problem, repeat from step 6).

**Stainless steel sheet replacement method Procedure 2**

- 1) Remove the screws (4 places) holding the stainless steel sheet and stainless steel sheet retainer plates (2 pieces) with using a Phillips screwdriver.
- 2) Pull out the old stainless steel sheet.

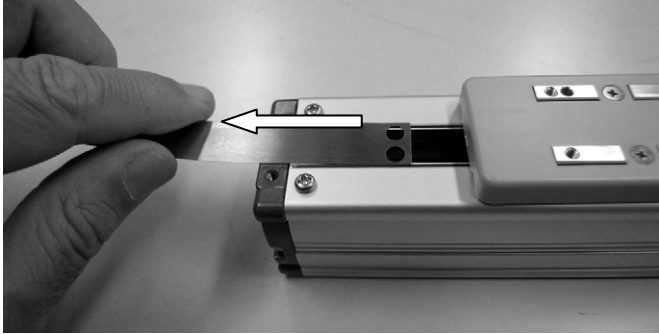

- 3) Attach adhesive tape on one side of new stainless steel sheet.

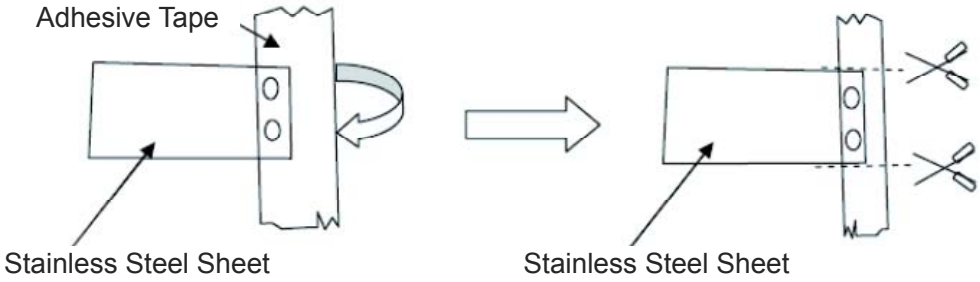

Attach adhesive tape so that it wraps around the end side of the stainless steel sheet. At that time, arrange it so that about 3mm of the end of the tape projects from the stainless steel sheet. Cut any tape excess.

- 4) Put the stainless steel sheet with an adhesive tape on the side cover.

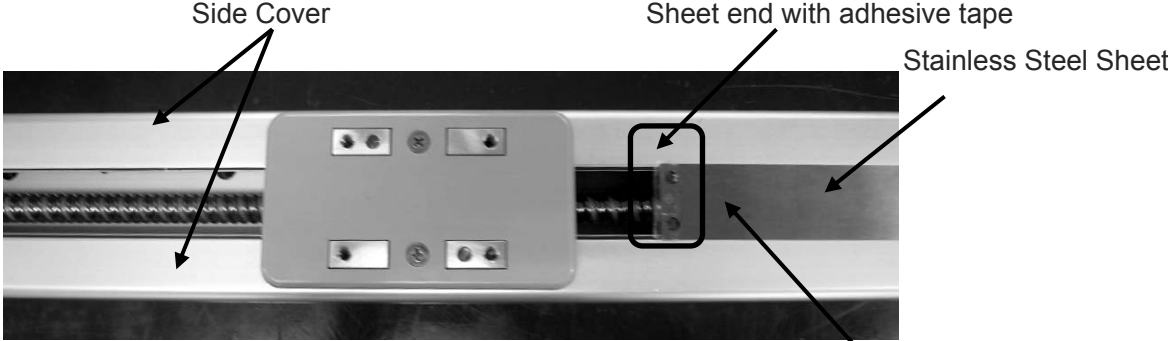

Take care not to drop the stainless steel sheet into the hole.

- 5) With the stainless steel sheet being held, move the slider to put through the stainless steel sheet.

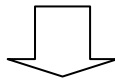
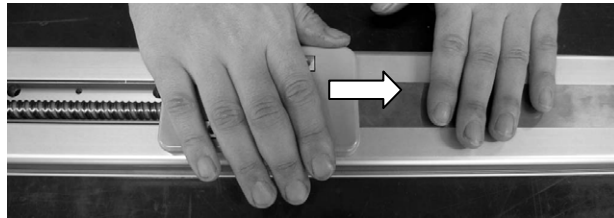
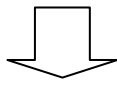
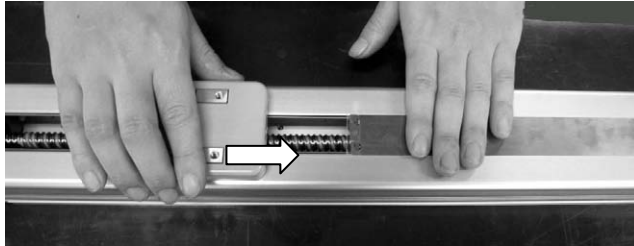

- 6) After the stainless steel sheet passes through the slider, pull one end of the stainless steel sheet out to the position of the stainless steel retainer plate. Take off the adhesive tape once positioning is finished.

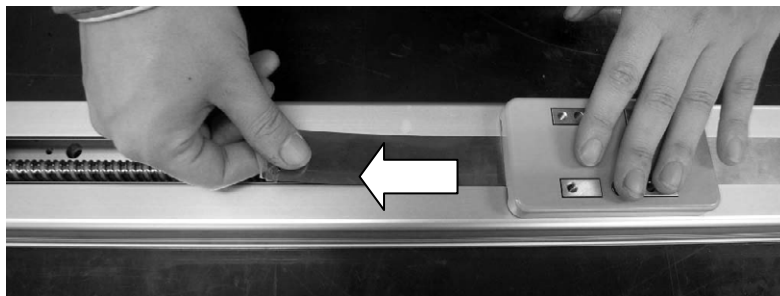

- 7) Fix the stainless steel sheet retainer plates using the screws (four locations). Use a Phillips screwdriver to attach it.



There are two grooves for stainless steel sheet attachment guides. Align so that the stainless steel sheet is positioned at the center between the two grooves. Attach the stainless steel sheet so that it is not bent.

Tightening Torque
41.4N•cm

- 8) After the stainless steel sheet retainer plates have been fixed, move the slider from one side to the other side (full stroke) with your hand to check that there is no rise or slackness in the stainless steel sheet. If there is any problem, repeat from step 7).



### Caution

- Make sure that there is no misalignment or slack in the stainless steel sheet. This may lead to damage to the stainless steel sheet.
- When installing the sheet clamp, do not apply excessive force to the stainless steel sheet.

### Notice

- As a guideline, the stainless steel sheet should last for about 5,000km of motion. However, depending on the usage or environment, replace the stainless steel sheet appropriately.
- It is available for customers to replace the stainless steel sheet. However, if you feel anxious about replacing it, it is recommended you ask us to do the replacement work for you. Either you bring in our product to our service office or our service staff visits your site to do the replacement work.

## Belt replacement/adjustment

### [Belt Inspection]

1) Detach the pulley cover affixing screws and take off the pulley cover.

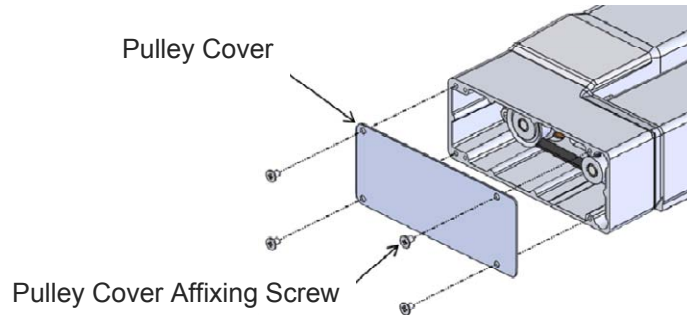

2) Check the condition of the belt visually.

### Judgment

- In generally speaking, it possesses bending life of several million times. However, the period of replacement for the belt cannot be clearly defined as the durability of it is impacted so much by the operational conditions.
- The timing belt gets worn away as the time passes, and it is necessary to have replacement at regular intervals with the following conditions as reference.
  - When the gear and belt area show obvious friction.
  - When swelling occurs as a result of oil adhesion.
  - When damages such as a crack occurs on the belt gear and back side.
- For the toothed belt, it is recommended to set the interval of regular replacement cycle when in use under high wire fatigue condition in high acceleration and deceleration because it is difficult to judge the right timing for replacement by checking appearance or looseness of the wires strengthening the belt.



**[Belt to Use]**

IAI uses the following belt in our plant

Model	Belt to Use	Manufacturer Name
SA4R	60S2M162R	Bando Chemical Industries, Ltd.
SA6R	60S3M207GB	Mitsuboshi Belting Ltd.
SA7R	100S3M240R	Bando Chemical Industries, Ltd.
SA8R	150S3M279GB	Mitsuboshi Belting Ltd.

**[Belt Replacement]**

- 1) Detach the pulley cover affixing screws and take off the pulley cover.

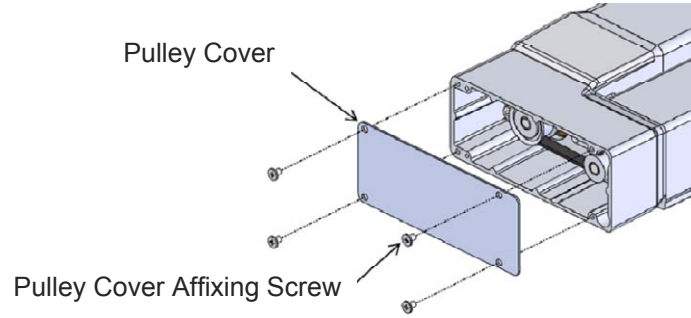

- 2) Loosen the motor unit affixing screw and take off the belt.

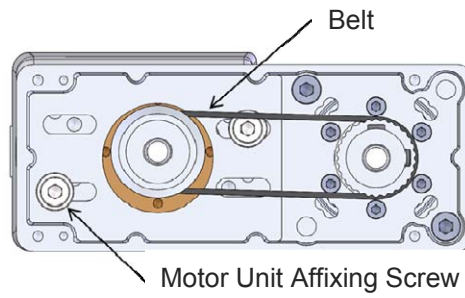

- 3) Replace the belt.
- 4) Adjust the belt tension.  
Keep the slider at the distance shown in the table below from the mechanical end.

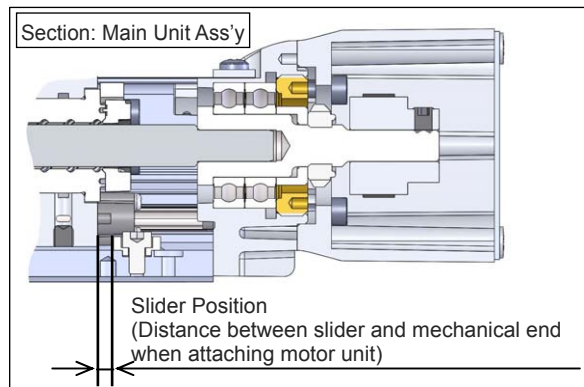

Slider Position

Model	Slider Position [mm]
SA4R, SA6R, SA7R and SA8R	2

- 5) With the origin mark marked on the motor end pulley facing outwards, hang the belt on the pulleys.

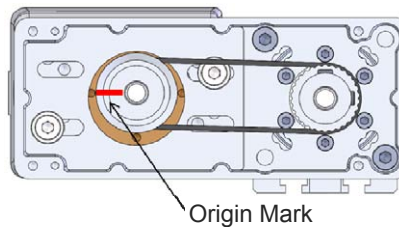

- 6) Apply tension in the force shown in the table below to the motor unit, and tighten the motor unit affixing screw in the tightening torque shown in the table below.

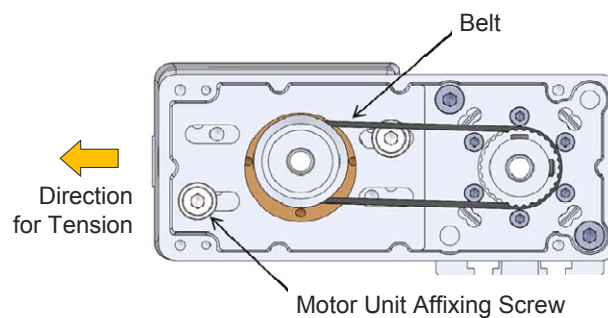

Tensile Force when Attaching Motor Unit

Model	Tension Force [N]
SA4R	20 to 25
SA6R	40 to 45
SA7R	70 to 80
SA8R	100 to 110

Motor Unit Affixing Screw Tightening Torque

Model	Tightening Torque [N•m]
SA4R and SA6R	2.1
SA7R and SA8R	4.1

7) Tighten up the pulley cover with the pulley cover affixing screws in the specified torque.

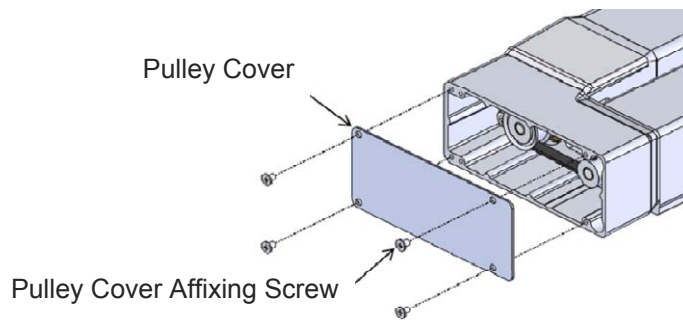

Pulley Cover Affixing Screw Tightening Torque

Model	Type of Screws	Tightening Torque [N•m]
SA4R	Cross Recessed Slim-Head Screw (SUS):M3	0.4
SA6R, SA7R, SA8R	Cross Recessed Flat-Head Screw (SUS):M3	0.4

## Motor Replacement

### [Motor Straight Type]

- 1) Detach the motor cover affixing screws.
- 2) Take off the end cover and motor cover.

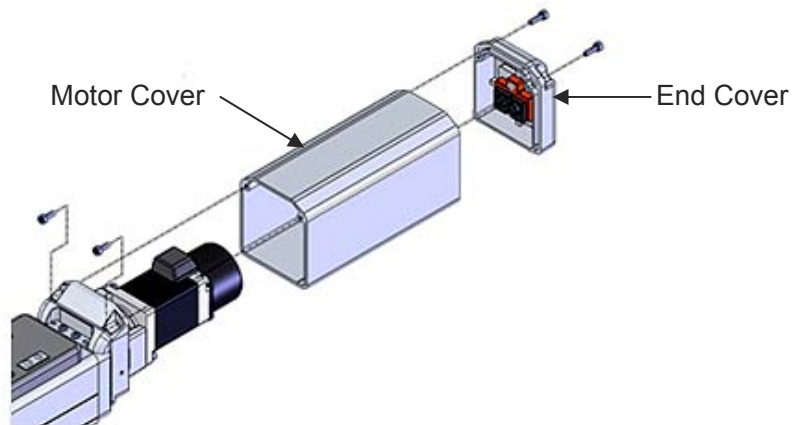

- 3) Move the slider to the position where the coupling screw on the actuator side can be seen.
- 4) Loosen the coupling screw, detach the motor affixing screws and take off the motor.

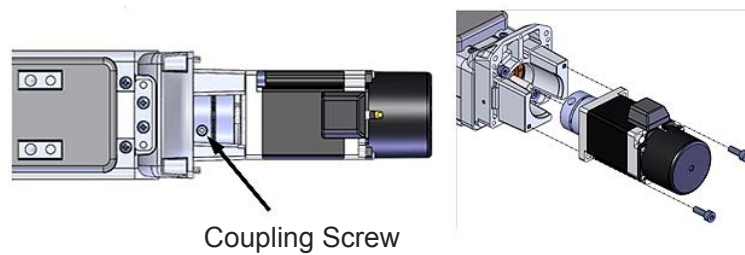

5) Keep the slider at the distance shown in the table below from the mechanical end.

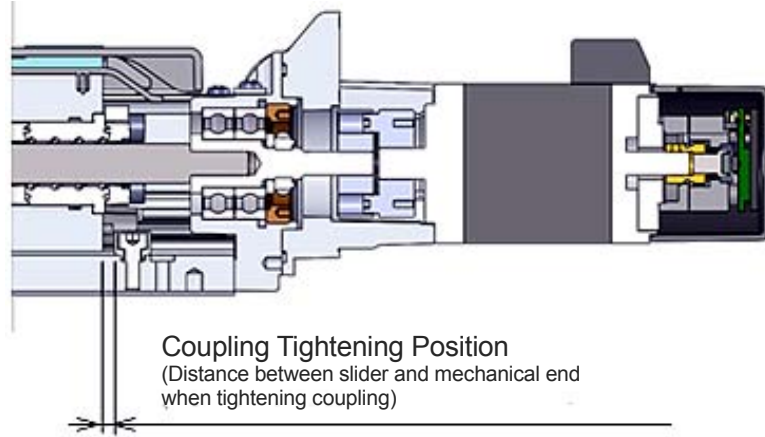

Coupling Tightening Position

Model	Coupling Tightening Position [mm] (Distance between Slider and Mechanical End)
SA4C	2
SA6C	2
SA7C	2
SA8C	2

6) Hold the motor for replacement loosely with the motor affixing screws, and then tighten the coupling screw in the tightening torque shown in the table.

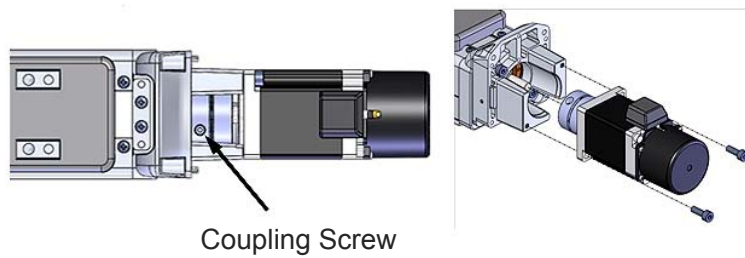

Coupling Screw Tightening Torque

Model	Tightening Torque [N•m]
SA4C	0.4
SA6C	0.9
SA7C	1.5
SA8C	1.5

- 7) Fully tighten the motor affixing screws in the tightening torque shown in the table.

Motor Affixing Screw Tightening Torque

Model	Tightening Torque [N•m]
SA4C	2.1
SA6C	2.1
SA7C	4.1
SA8C	4.1

- 8) Attach the motor cover and end cover.

Tighten the motor cover affixing screws in the tightening torque shown in the table.

Pay attention not to get the cable pinched.

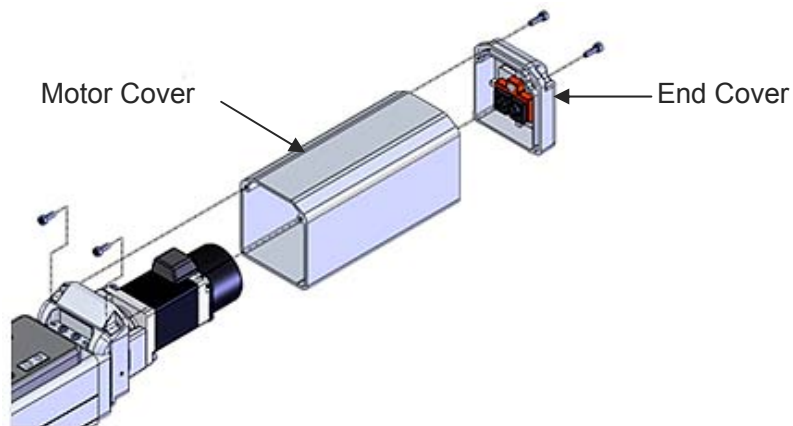

Motor Cover Affixing Screw Tightening Torque

Model	Type of Screws	Tightening Torque [N•m]
SA4C	Hexagonal Socket Head Bolt:M3	0.9
SA6C	Hexagonal Socket Head Bolt:M3	0.9
SA7C	Hexagonal Socket Head Bolt:M4	2.1
SA8C	Hexagonal Socket Head Bolt:M4	2.1

[Motor Reversing Type: When Replacing Motor Unit]

- 1) Detach the pulley cover affixing screws and take off the pulley cover.

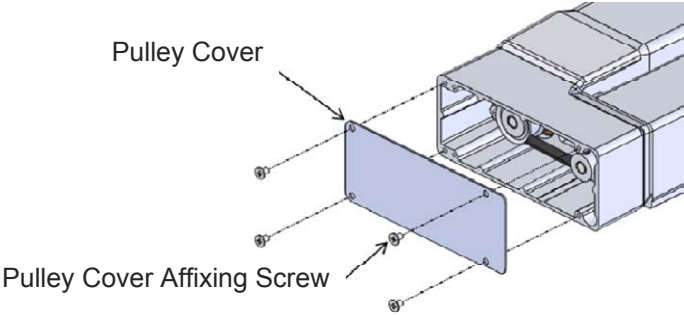

- 2) Detach the motor unit affixing screw and take off the belt.

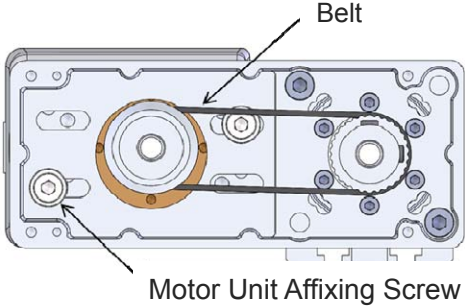

- 3) Detach the motor unit.

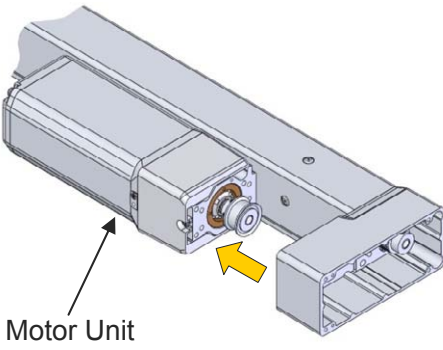



- 4) Attach the motor unit for replacement.
- 5) Keep the table at the distance shown in the table below from the mechanical end.

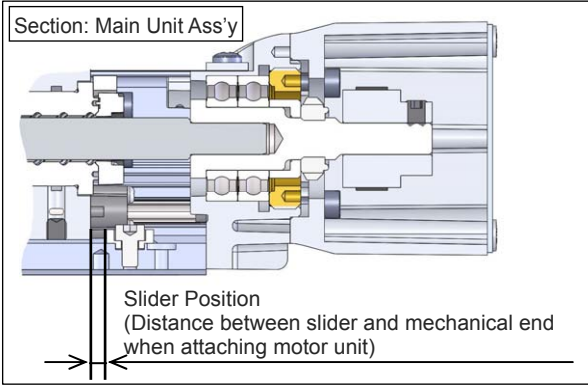

Slider Position

Model	Slider Position [mm]
SA4R, SA6R, SA7R and SA8R	2

- 6) With the origin mark marked on the motor end pulley facing outwards, hang the belt on the pulleys.

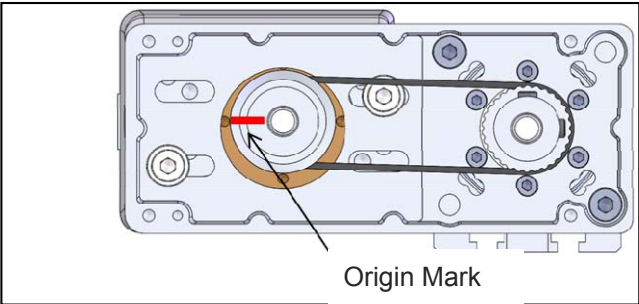

- 7) Apply tension in the force shown in the table below to the motor unit, and tighten the motor unit affixing screw in the tightening torque shown in the table below.

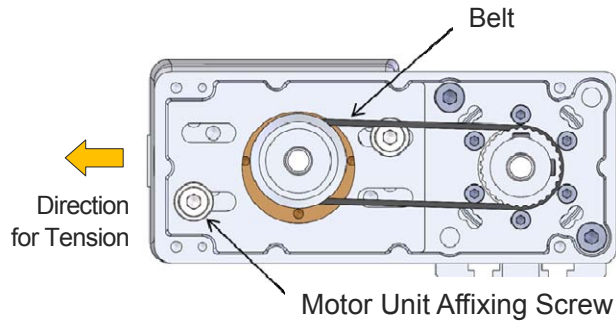

Tensile Force when Attaching Motor Unit

Model	Tension Force [N]
SA4R	20 to 25
SA6R	40 to 45
SA7R	70 to 80
SA8R	100 to 110

Motor Unit Affixing Screw Tightening Torque

Model	Tightening Torque [N·m]
SA4R and SA6R	2.1
SA7R and SA8R	4.1

- 8) Tighten up the pulley cover with the pulley cover affixing screws in the specified torque.

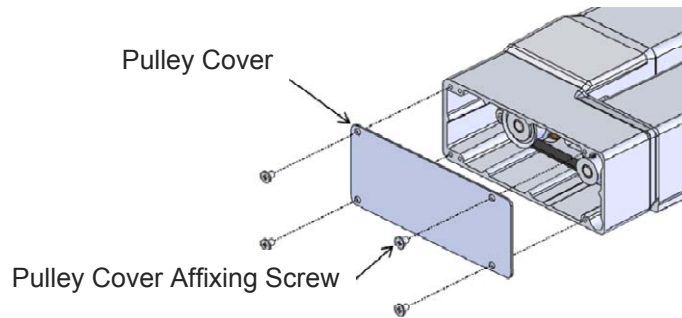

Pulley Cover Affixing Screw Tightening Torque

Model	Type of Screws	Tightening Torque [N•m]
SA4R	Cross Recessed Slim-Head Screw (SUS):M3	0.4
SA6R, SA7R, SA8R	Cross Recessed Flat-Head Screw (SUS):M3	0.4



### Caution

Make sure to hold the slider so it would not move in case of replacing a motor in vertical installation which is not equipped with a brake. It will be dangerous as the slider will be dropped, if it is not held, as soon as the motor gets taken off.

---

### Notice

- Pay attention not to get the cable pinched when attaching the motor cover and end cover.
  - When the actuator is not equipped with a brake, make sure that the motor is magnetized when attaching it so the shaft and the origin point get aligned.
-

# ROBO Cylinder

---

# Chapter 5

## External Dimensions

5.1	External Dimensions	5-1
	RCS4-SA4C	5-1
	RCS4-SA6C	5-2
	RCS4-SA7C	5-3
	RCS4-SA8C	5-4
	RCS4-SA4R	5-5
	RCS4-SA6R	5-7
	RCS4-SA7R	5-8
	RCS4-SA8R	5-10
	RCS4CR-SA4C	5-12
	RCS4CR-SA6C	5-13
	RCS4CR-SA7C	5-14
	RCS4CR-SA8C	5-15

## 5.1 External Dimensions

# 5.1 External Dimensions



ST: Stroke, M.E.: Mechanical End, S.E.: Stroke End

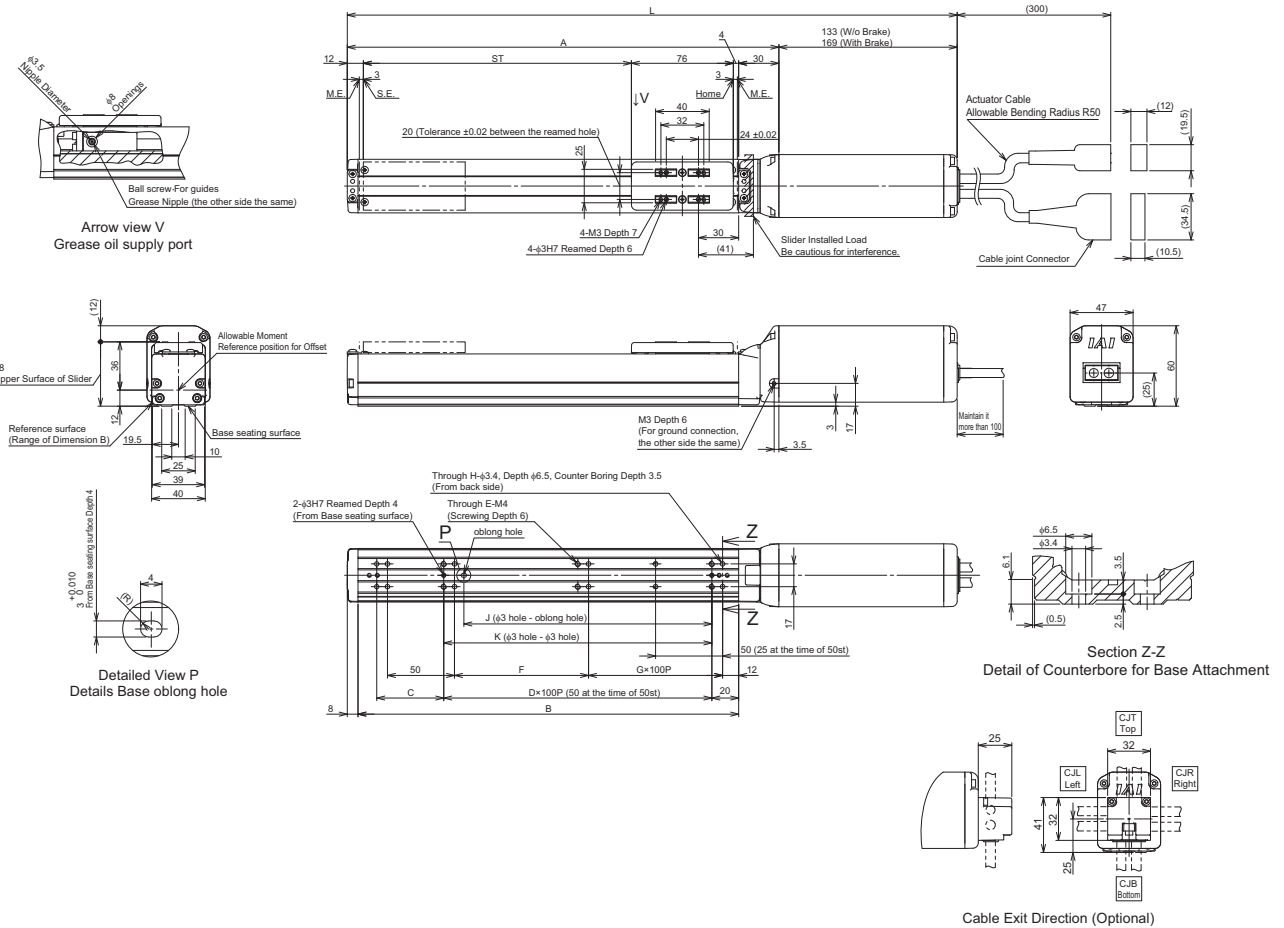

### ■ Dimensions and Mass by Stroke

Unit: mm

Stroke	L		A	B	C	D	E	F	G	H	J	K	Mass [kg]	
	W/o Brake	With Brake											W/o Brake	With Brake
50	305	341	172	134	50	-	6	50	0	8	35	50	1.2	1.4
100	355	391	222	184	50	1	6	100	0	8	85	100	1.3	1.5
150	405	441	272	234	100	1	6	50	1	10	85	100	1.4	1.6
200	455	491	322	284	50	2	8	100	1	10	185	200	1.5	1.7
250	505	541	372	334	100	2	8	50	2	12	185	200	1.5	1.7
300	555	591	422	384	50	3	10	100	2	12	285	300	1.6	1.8
350	605	641	472	434	100	3	10	50	3	14	285	300	1.7	1.9
400	655	691	522	484	50	4	12	100	3	14	385	400	1.8	2.0
450	705	741	572	534	100	4	12	50	4	16	385	400	1.9	2.1
500	755	791	622	584	50	5	14	100	4	16	485	500	2.0	2.2



ST: Stroke, M.E.: Mechanical End, S.E.: Stroke End

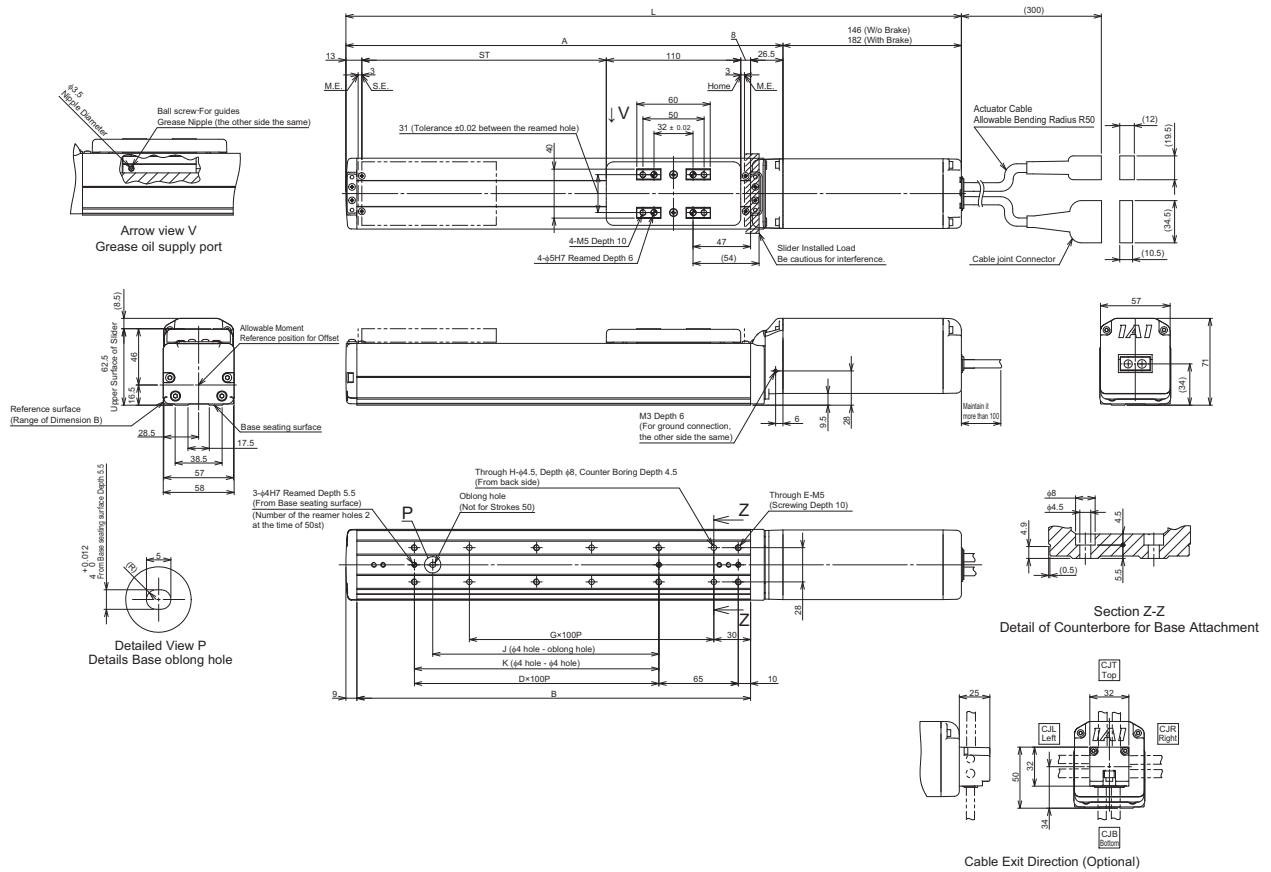

5. External Dimensions

■ Dimensions and Mass by Stroke

Unit: mm

Stroke	L		A	B	D	E	G	H	J	K	Mass [kg]	
	W/o Brake	With Brake									W/o Brake	With Brake
50	353.5	389.5	207.5	172	0	4	1	4	0	0	2.0	2.3
100	403.5	439.5	257.5	222	1	6	1	4	85	100	2.2	2.5
150	453.5	489.5	307.5	272	1	6	2	6	85	100	2.4	2.7
200	503.5	539.5	357.5	322	2	8	2	6	185	200	2.6	2.9
250	553.5	589.5	407.5	372	2	8	3	8	185	200	2.7	3.0
300	603.5	639.5	457.5	422	3	10	3	8	285	300	2.9	3.2
350	653.5	689.5	507.5	472	3	10	4	10	285	300	3.1	3.4
400	703.5	739.5	557.5	522	4	12	4	10	385	400	3.3	3.6
450	753.5	789.5	607.5	572	4	12	5	12	385	400	3.4	3.7
500	803.5	839.5	657.5	622	5	14	5	12	485	500	3.6	3.9
550	853.5	889.5	707.5	672	5	14	6	14	485	500	3.8	4.1
600	903.5	939.5	757.5	722	6	16	6	14	585	600	4.0	4.3
650	953.5	989.5	807.5	772	6	16	7	16	585	600	4.2	4.5
700	1003.5	1039.5	857.5	822	7	18	7	16	685	700	4.3	4.6
750	1053.5	1089.5	907.5	872	7	18	8	18	685	700	4.5	4.8
800	1103.5	1139.5	957.5	922	8	20	8	18	785	800	4.7	5.0

## 5.1 External Dimensions



ST: Stroke, M.E.: Mechanical End, S.E.: Stroke End

5. External Dimensions

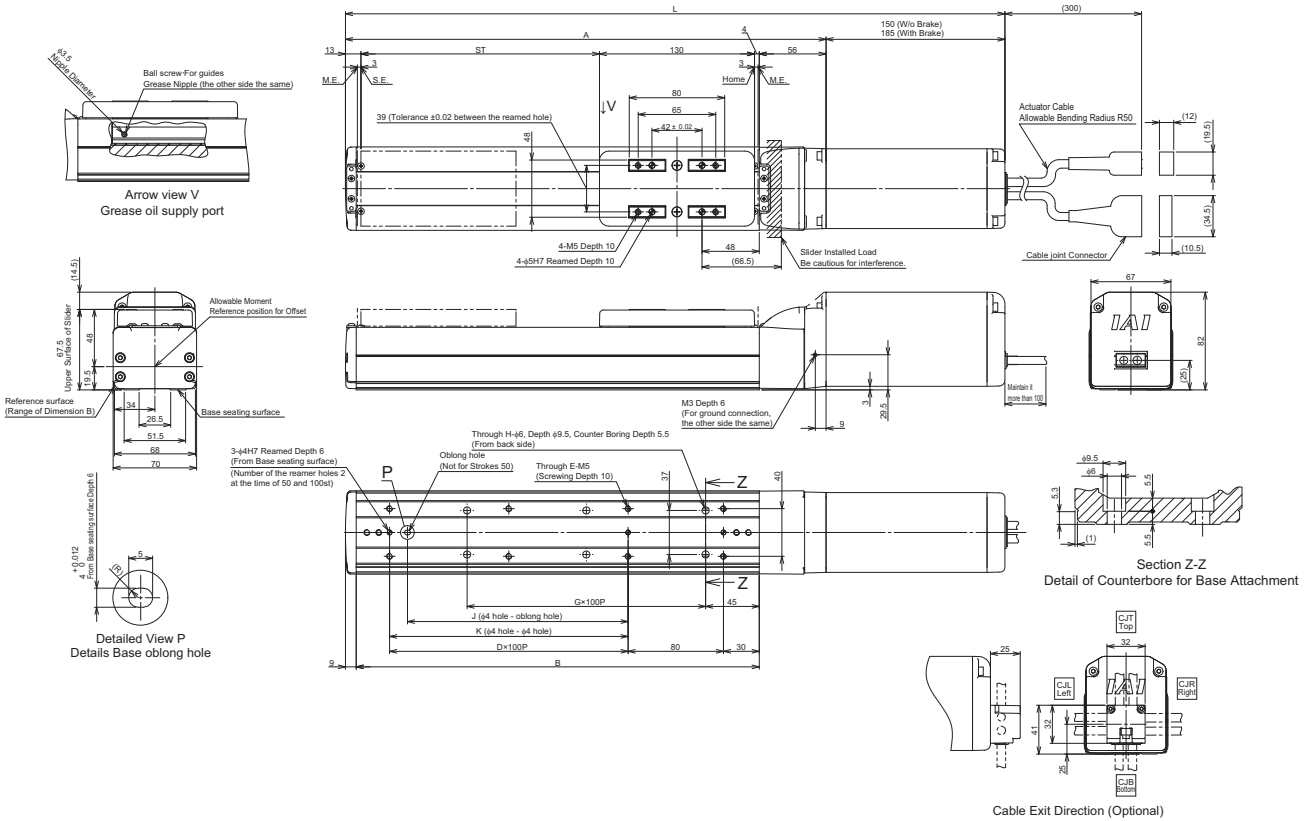

■ Dimensions and Mass by Stroke

Unit: mm

Stroke	L		A	B	D	E	G	H	J	K	Mass [kg]	
	W/o Brake	With Brake									W/o Brake	With Brake
50	403	438	253	188	0	4	1	4	0	0	3.5	4.0
100	453	488	303	238	1	6	1	4	85	0	3.8	4.3
150	503	538	353	288	1	6	2	6	85	100	4.0	4.5
200	553	588	403	338	2	8	2	6	185	200	4.3	4.8
250	603	638	453	388	2	8	3	8	185	200	4.5	5.0
300	653	688	503	438	3	10	3	8	285	300	4.7	5.2
350	703	738	553	488	3	10	4	10	285	300	5.0	5.5
400	753	788	603	538	4	12	4	10	385	400	5.2	5.7
450	803	838	653	588	4	12	5	12	385	400	5.4	5.9
500	853	888	703	638	5	14	5	12	485	500	5.7	6.2
550	903	938	753	688	5	14	6	14	485	500	5.9	6.4
600	953	988	803	738	6	16	6	14	585	600	6.1	5.6
650	1003	1038	853	788	6	16	7	16	585	600	6.4	6.9
700	1053	1088	903	838	7	18	7	16	685	700	6.6	7.1
750	1103	1138	953	888	7	18	8	18	685	700	6.8	7.3
800	1153	1188	1003	938	8	20	8	18	785	800	7.1	7.6





## 5.1 External Dimensions



ST: Stroke, M.E.: Mechanical End, S.E.: Stroke End

5. External Dimensions

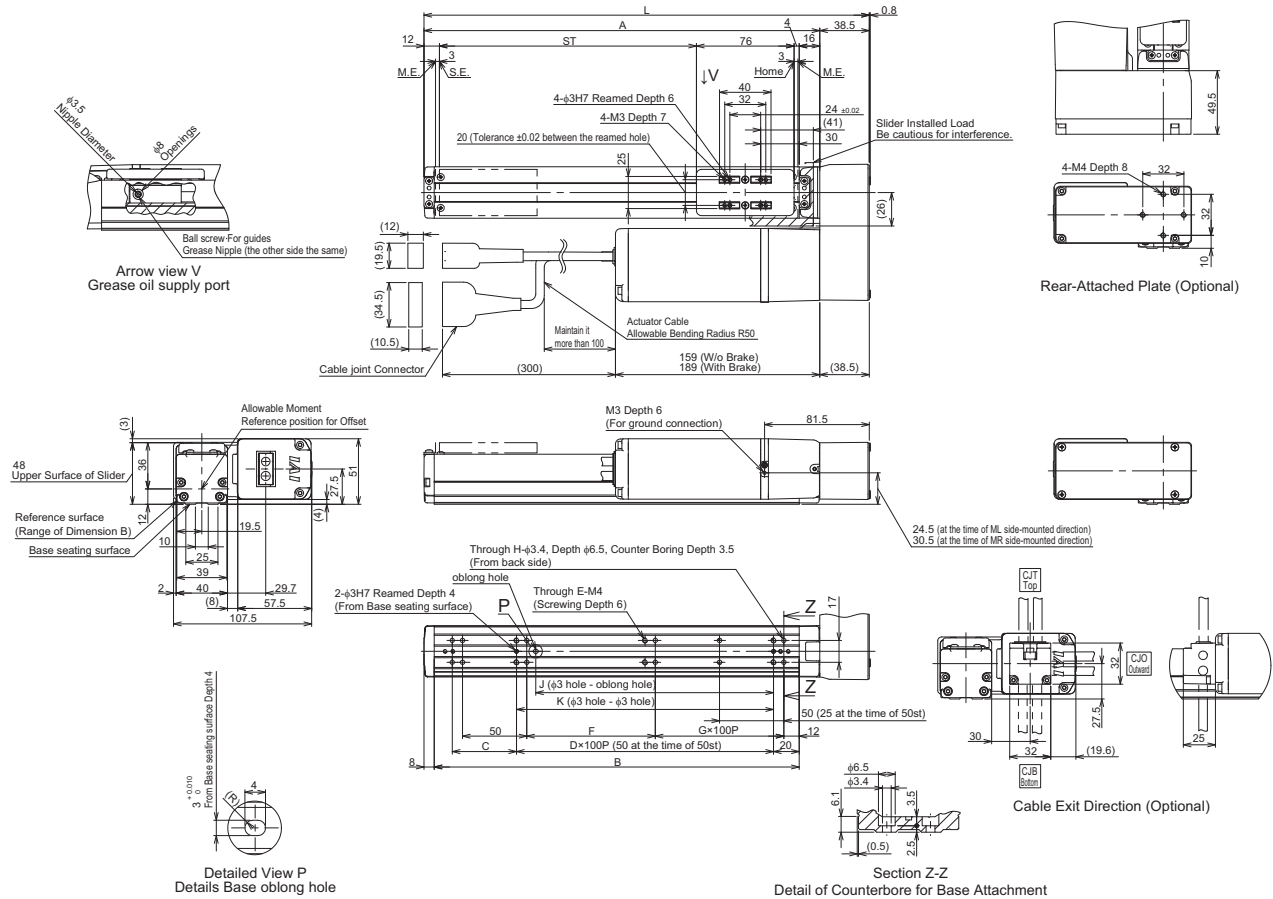

### ■ Dimensions and Mass by Stroke

Unit: mm

Stroke	L	A	B	C	D	E	F	G	H	J	K	Mass [kg]	
												W/o Brake	With Brake
50	196.5	158	134	50	-	6	50	0	8	35	50	1.5	1.7
100	246.5	208	184	50	1	6	100	0	8	85	100	1.6	1.8
150	296.5	258	234	100	1	6	50	1	10	85	100	1.7	1.9
200	346.5	308	284	50	2	8	100	1	10	185	200	1.7	1.9
250	396.5	358	334	100	2	8	50	2	12	185	200	1.8	2.0
300	446.5	408	384	50	3	10	100	2	12	285	300	1.9	2.1
350	496.5	458	434	100	3	10	50	3	14	285	300	2.0	2.2
400	546.5	508	484	50	4	12	100	3	14	385	400	2.1	2.3
450	596.5	558	534	100	4	12	50	4	16	385	400	2.2	2.4
500	646.5	608	584	50	5	14	100	4	16	485	500	2.3	2.5

Slider Spacer (Optional Model: SS)

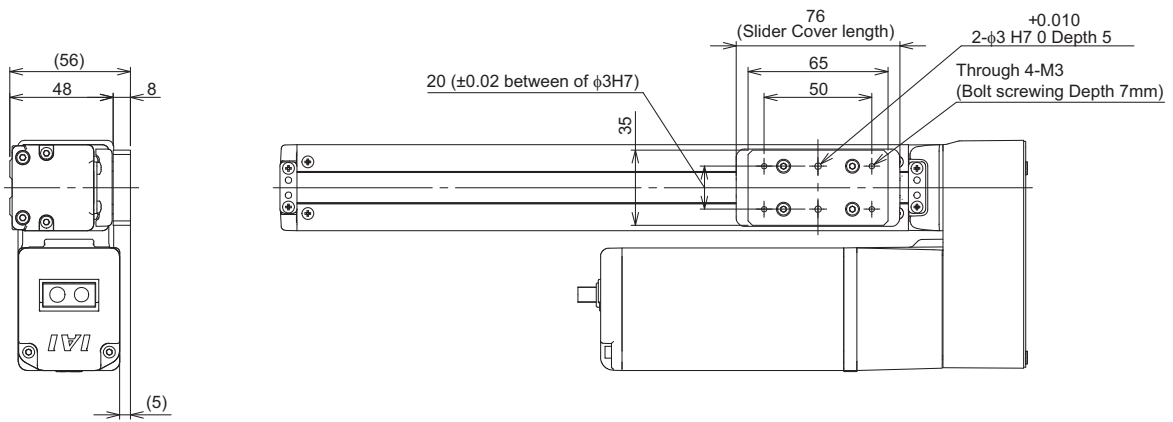

## 5.1 External Dimensions



ST: Stroke, M.E.: Mechanical End, S.E.: Stroke End

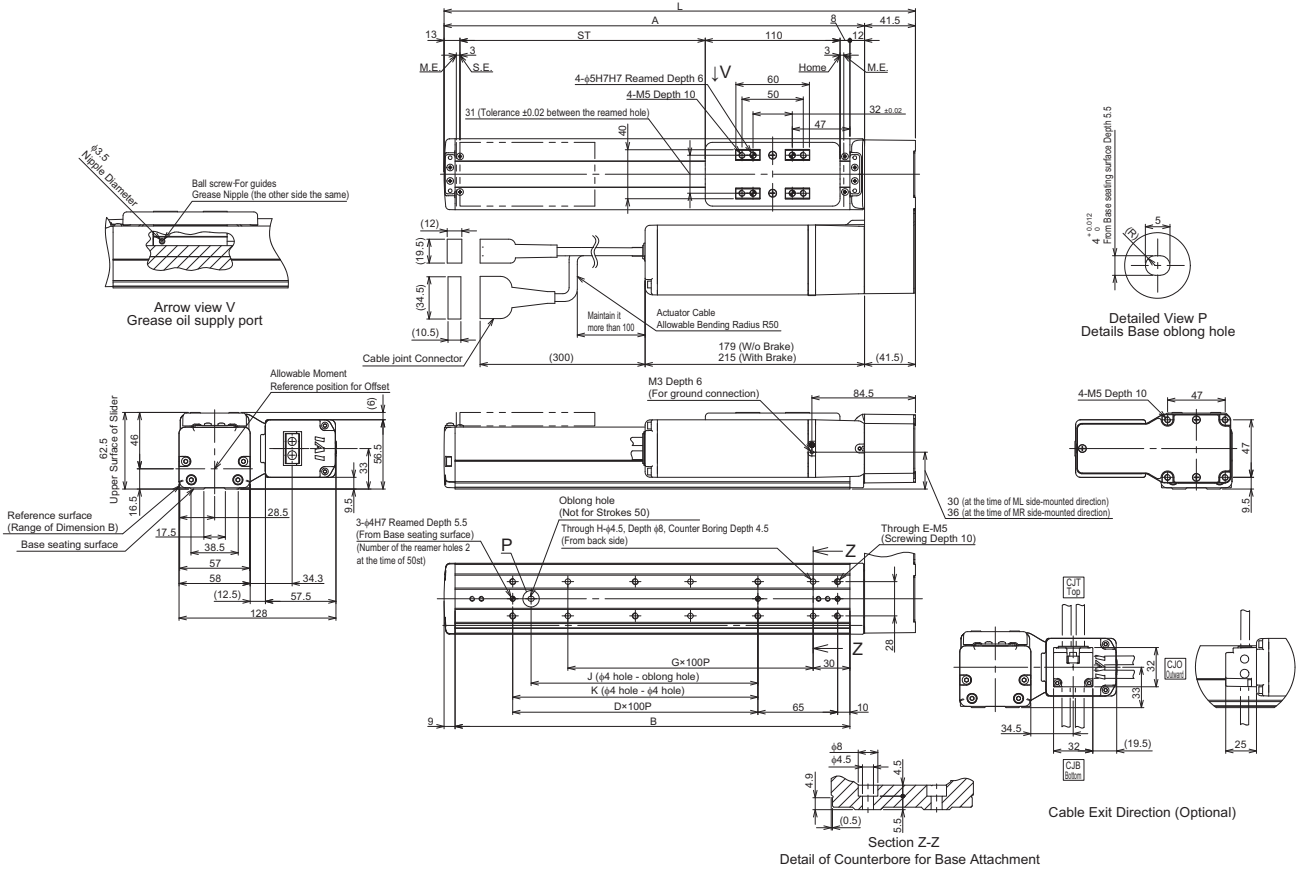

### ■ Dimensions and Mass by Stroke

Unit: mm

Stroke	L	A	B	D	E	G	H	J	K	Mass [kg]	
										W/o Brake	With Brake
50	234.5	193	172	0	4	1	4	0	0	2.4	2.7
100	284.5	243	222	1	6	1	4	85	100	2.5	2.8
150	334.5	293	272	1	6	2	6	85	100	2.7	3.0
200	384.5	343	322	2	8	2	6	185	200	2.9	3.2
250	434.5	393	372	2	8	3	8	185	200	3.1	3.4
300	484.5	443	422	3	10	3	8	285	300	3.2	3.5
350	534.5	493	472	3	10	4	10	285	300	3.4	3.7
400	584.5	543	522	4	12	4	10	385	400	3.6	3.9
450	634.5	593	572	4	12	5	12	385	400	3.8	4.1
500	684.5	643	622	5	14	5	12	485	500	4.0	4.3
550	734.5	693	672	5	14	6	14	485	500	4.1	4.4
600	784.5	743	722	6	16	6	14	585	600	4.3	4.6
650	834.5	793	772	6	16	7	16	585	600	4.5	4.8
700	884.5	843	822	7	18	7	16	685	700	4.7	5.0
750	934.5	893	872	7	18	8	18	685	700	4.9	5.2
800	984.5	943	922	8	20	8	18	785	800	5.0	5.3



ST: Stroke, M.E.: Mechanical End, S.E.: Stroke End

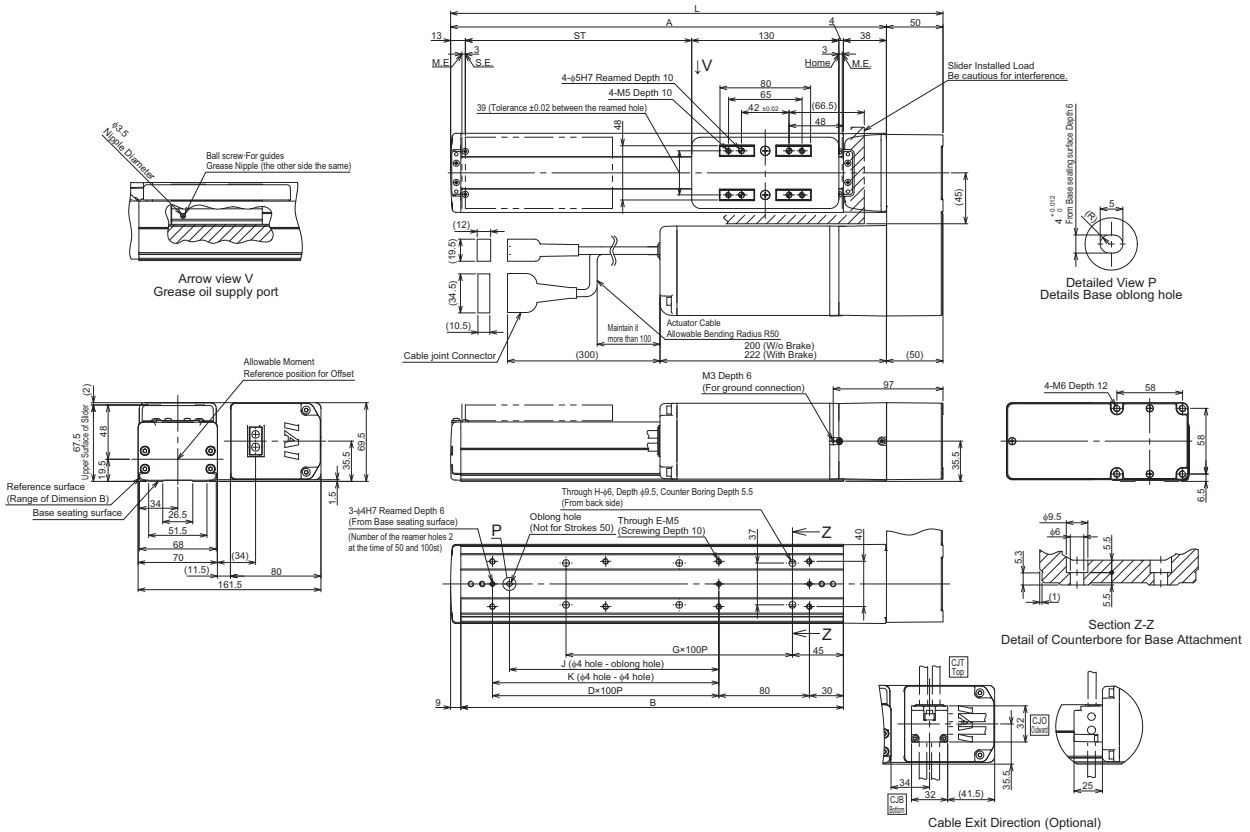

■ Dimensions and Mass by Stroke

Unit: mm

Stroke	L	A	B	D	E	G	H	J	K	Mass [kg]	
										W/o Brake	With Brake
50	285	235	188	0	4	1	4	0	0	4.3	4.8
100	335	285	238	1	6	1	4	85	0	4.6	5.1
150	385	335	288	1	6	2	6	85	100	4.8	5.3
200	435	385	338	2	8	2	6	185	200	5.0	5.5
250	485	435	388	2	8	3	8	185	200	5.3	5.8
300	535	485	438	3	10	3	8	285	300	5.5	6.0
350	585	535	488	3	10	4	10	285	300	5.8	6.3
400	635	585	538	4	12	4	10	385	400	6.0	6.5
450	685	635	588	4	12	5	12	385	400	6.2	6.7
500	735	685	638	5	14	5	12	485	500	6.5	7.0
550	785	735	688	5	14	6	14	485	500	6.7	7.2
600	835	785	738	6	16	6	14	585	600	6.9	7.4
650	885	835	788	6	16	7	16	585	600	7.2	7.7
700	935	885	838	7	18	7	16	685	700	7.4	7.9
750	985	935	888	7	18	8	18	685	700	7.6	8.1
800	1035	985	938	8	20	8	18	785	800	7.9	8.4

5.1 External Dimensions

Slider Spacer (Optional Model: SS)

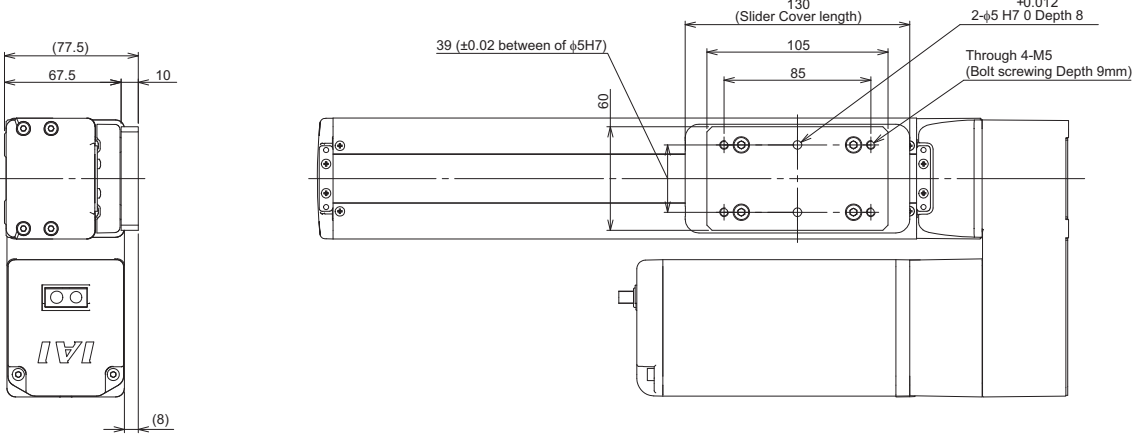

5. External Dimensions



ST: Stroke, M.E.: Mechanical End, S.E.: Stroke End

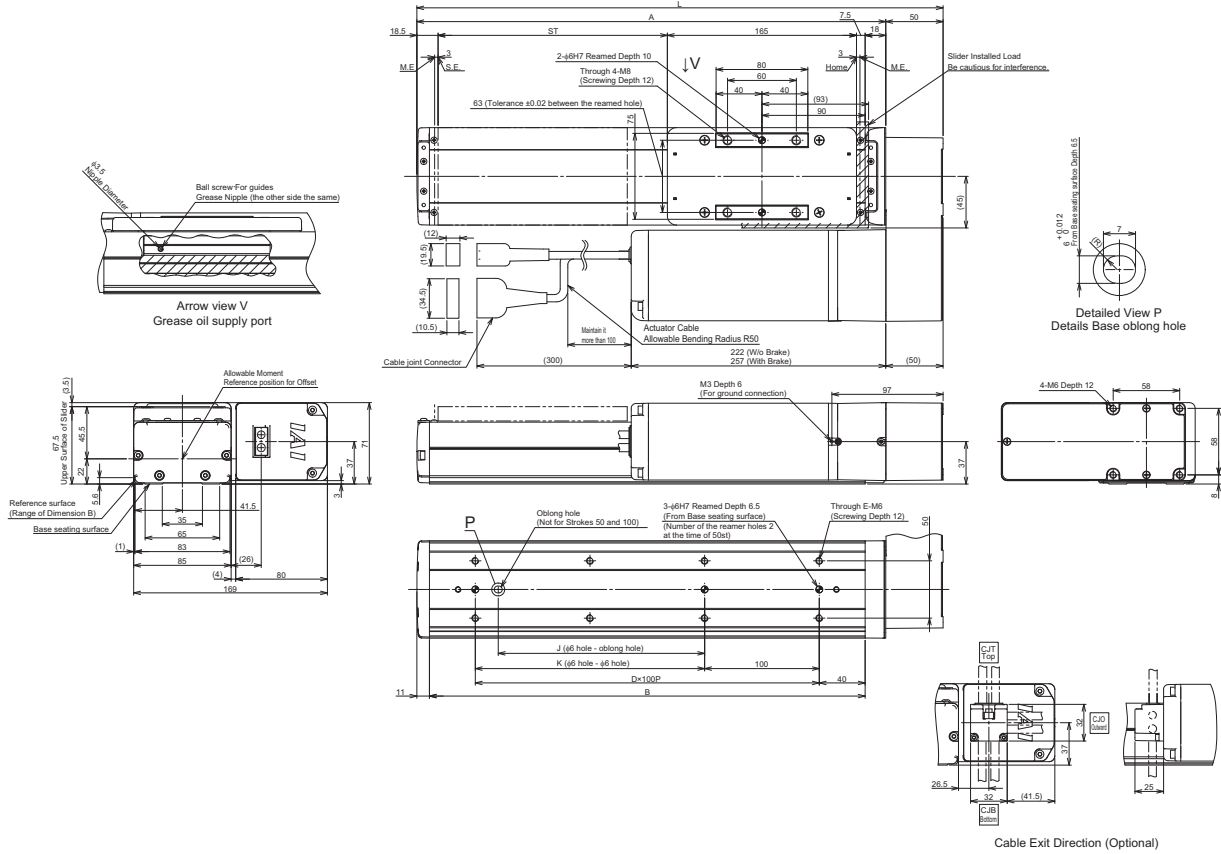

5. External Dimensions

■ Dimensions and Mass by Stroke Unit: mm

Stroke	L	A	B	D	E	J	K	Mass [kg]	
								W/o Brake	With Brake
50	309	259	230	1	4	0	0	5.6	6.1
100	359	309	280	2	6	0	100	5.9	6.4
150	409	359	330	2	6	80	100	6.2	6.7
200	459	409	380	3	8	180	200	6.4	6.9
250	509	459	430	3	8	180	200	6.7	7.2
300	559	509	480	4	10	280	300	7.0	7.5
350	609	559	530	4	10	280	300	7.3	7.8
400	659	609	580	5	12	380	400	7.6	8.1
450	709	659	630	5	12	380	400	7.9	8.4
500	759	709	680	6	14	480	500	8.2	8.7
550	809	759	730	6	14	480	500	8.5	9.0
600	859	809	780	7	16	580	600	8.8	9.3
650	909	859	830	7	16	580	600	9.1	9.6
700	959	909	880	8	18	680	700	9.4	9.9
750	1009	959	930	8	18	680	700	9.6	10.1
800	1059	1009	980	9	20	780	800	9.9	10.4
850	1109	1059	1030	9	20	780	800	10.2	10.7
900	1159	1109	1080	10	22	880	900	10.5	11.0
950	1209	1159	1130	10	22	880	900	10.8	11.3
1000	1259	1209	1180	11	24	980	1000	11.1	11.6
1050	1309	1259	1230	11	24	980	1000	11.4	11.9
1100	1359	1309	1280	12	26	1080	1100	11.7	12.2

5.1 External Dimensions

Slider Spacer (Optional Model: SS)

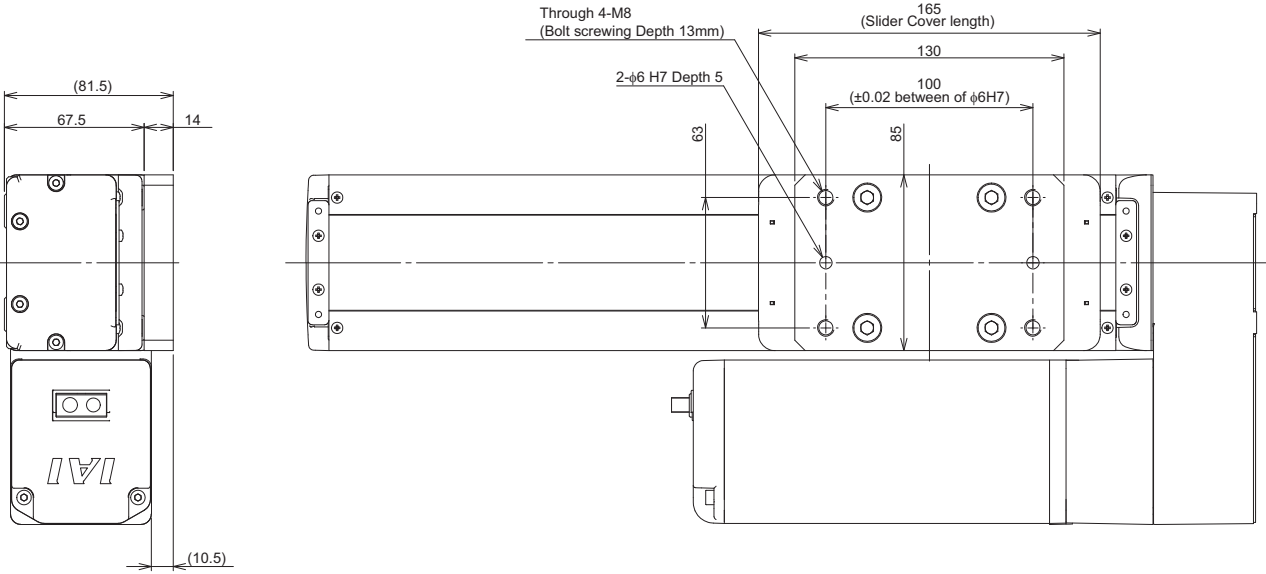

5. External Dimensions





ST: Stroke, M.E.: Mechanical End, S.E.: Stroke End

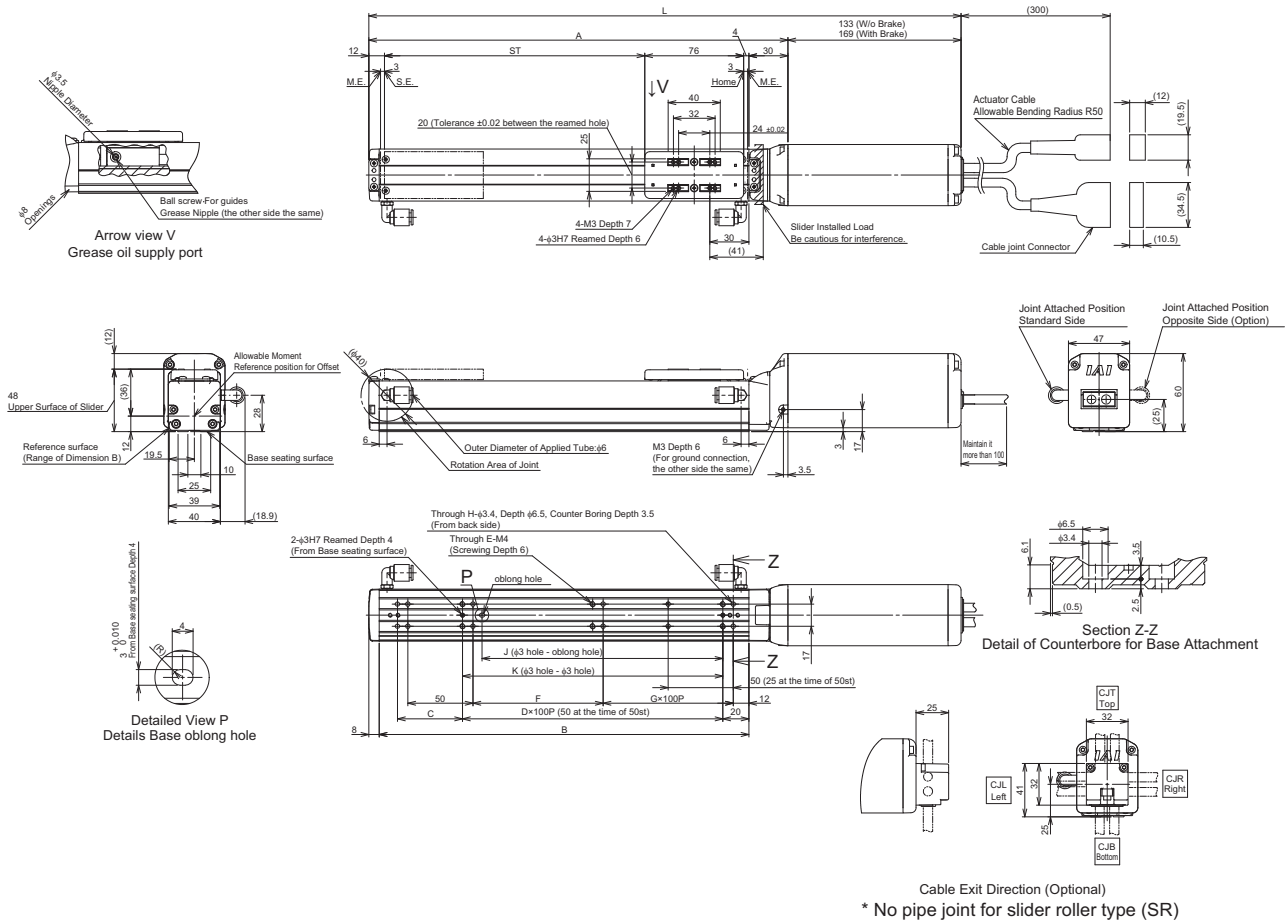

Cable Exit Direction (Optional)  
 \* No pipe joint for slider roller type (SR)

■ Dimensions and Mass by Stroke

Unit: mm

Stroke	L		A	B	C	D	E	F	G	H	J	K	Mass [kg]	
	W/o Brake	With Brake											W/o Brake	With Brake
50	305	341	172	134	50	-	6	50	0	8	35	50	1.2	1.4
100	355	391	222	184	50	1	6	100	0	8	85	100	1.3	1.5
150	405	441	272	234	100	1	6	50	1	10	85	100	1.4	1.6
200	455	491	322	284	50	2	8	100	1	10	185	200	1.5	1.7
250	505	541	372	334	100	2	8	50	2	12	185	200	1.5	1.7
300	555	591	422	384	50	3	10	100	2	12	285	300	1.6	1.8
350	605	641	472	434	100	3	10	50	3	14	285	300	1.7	1.9
400	655	691	522	484	50	4	12	100	3	14	385	400	1.8	2.0
450	705	741	572	534	100	4	12	50	4	16	385	400	1.9	2.1
500	755	791	622	584	50	5	14	100	4	16	485	500	2.0	2.2

## 5.1 External Dimensions



ST: Stroke, M.E.: Mechanical End, S.E.: Stroke End

### 5. External Dimensions

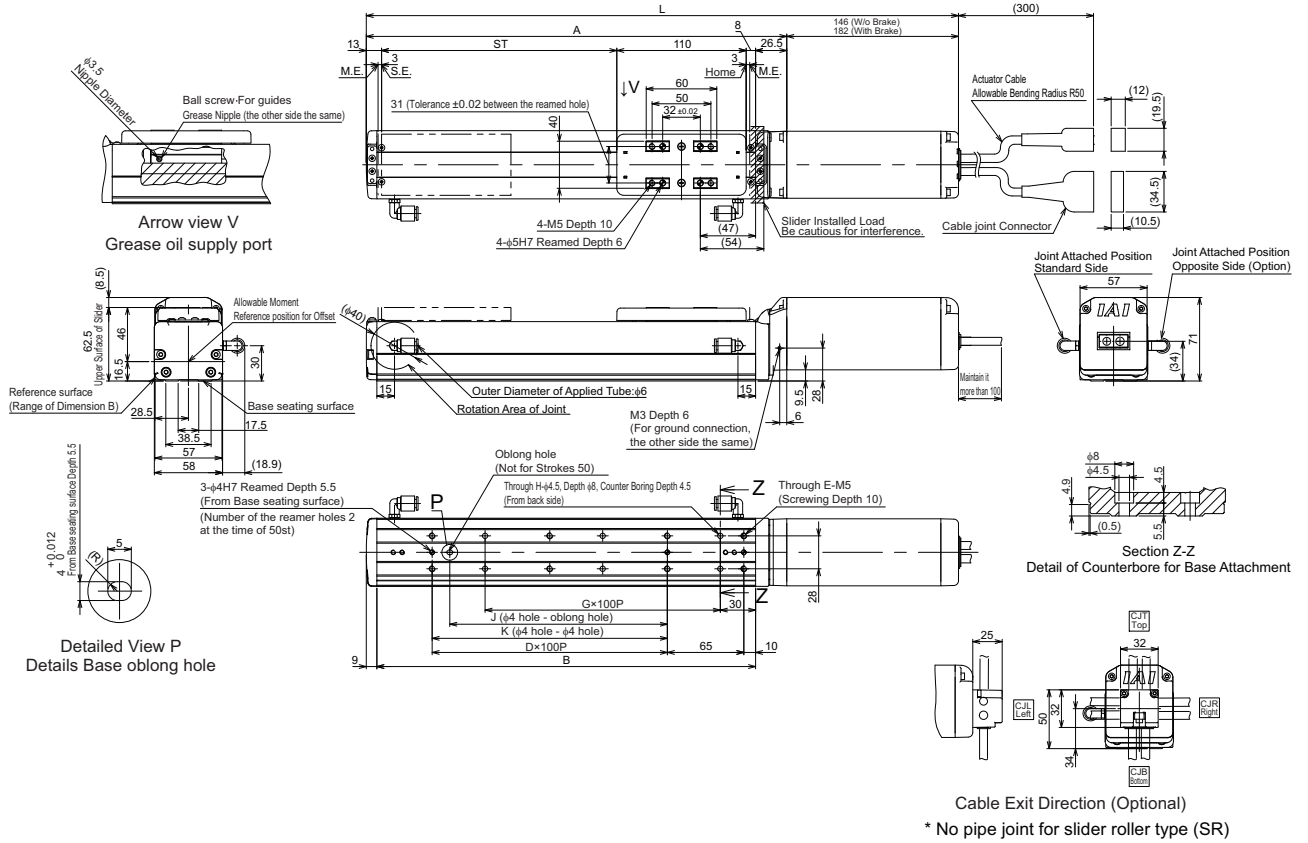

\* No pipe joint for slider roller type (SR)

### ■ Dimensions and Mass by Stroke

Unit: mm

Stroke	L		A	B	D	E	G	H	J	K	Mass [kg]	
	W/o Brake	With Brake									W/o Brake	With Brake
50	353.5	389.5	207.5	172	0	4	1	4	0	0	2.0	2.3
100	403.5	439.5	257.5	222	1	6	1	4	85	100	2.2	2.5
150	453.5	489.5	307.5	272	1	6	2	6	85	100	2.4	2.7
200	503.5	539.5	357.5	322	2	8	2	6	185	200	2.6	2.9
250	553.5	589.5	407.5	372	2	8	3	8	185	200	2.7	3.0
300	603.5	639.5	457.5	422	3	10	3	8	285	300	2.9	3.2
350	653.5	689.5	507.5	472	3	10	4	10	285	300	3.1	3.4
400	703.5	739.5	557.5	522	4	12	4	10	385	400	3.3	3.6
450	753.5	789.5	607.5	572	4	12	5	12	385	400	3.4	3.7
500	803.5	839.5	657.5	622	5	14	5	12	485	500	3.6	3.9
550	853.5	889.5	707.5	672	5	14	6	14	485	500	3.8	4.1
600	903.5	939.5	757.5	722	6	16	6	14	585	600	4.0	4.3
650	953.5	989.5	807.5	772	6	16	7	16	585	600	4.2	4.5
700	1003.5	1039.5	857.5	822	7	18	7	16	685	700	4.3	4.6
750	1053.5	1089.5	907.5	872	7	18	8	18	685	700	4.5	4.8
800	1103.5	1139.5	957.5	922	8	20	8	18	785	800	4.7	5.0



ST: Stroke, M.E.: Mechanical End, S.E.: Stroke End

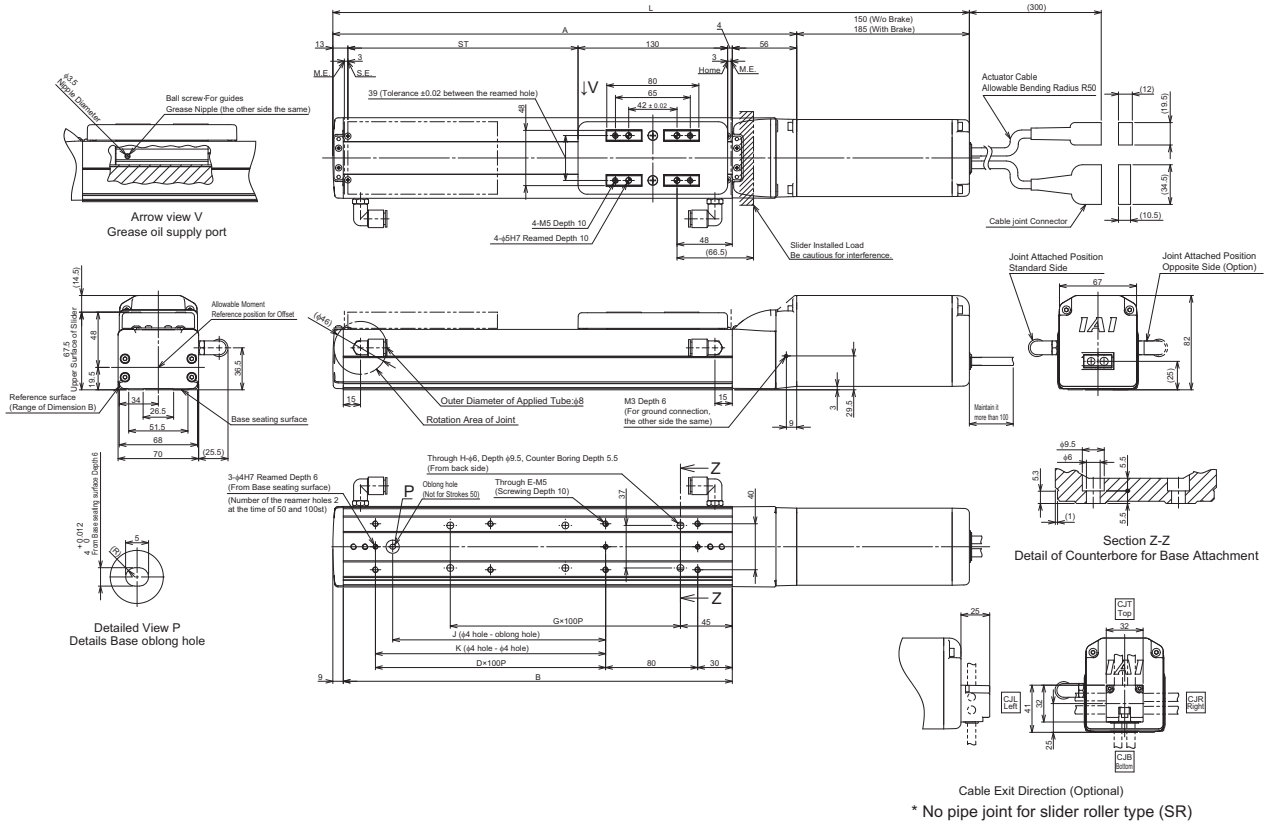

5. External Dimensions

■ Dimensions and Mass by Stroke

Unit: mm

Stroke	L		A	B	D	E	G	H	J	K	Mass [kg]	
	W/o Brake	With Brake									W/o Brake	With Brake
50	403	438	253	188	0	4	1	4	0	0	3.5	4.0
100	453	488	303	238	1	6	1	4	85	0	3.8	4.3
150	503	538	353	288	1	6	2	6	85	100	4.0	4.5
200	553	588	403	338	2	8	2	6	185	200	4.3	4.8
250	603	638	453	388	2	8	3	8	185	200	4.5	5.0
300	653	688	503	438	3	10	3	8	285	300	4.7	5.2
350	703	738	553	488	3	10	4	10	285	300	5.0	5.5
400	753	788	603	538	4	12	4	10	385	400	5.2	5.7
450	803	838	653	588	4	12	5	12	385	400	5.4	5.9
500	853	888	703	638	5	14	5	12	485	500	5.7	6.2
550	903	938	753	688	5	14	6	14	485	500	5.9	6.4
600	953	988	803	738	6	16	6	14	585	600	6.1	5.6
650	1003	1038	853	788	6	16	7	16	585	600	6.4	6.9
700	1053	1088	903	838	7	18	7	16	685	700	6.6	7.1
750	1103	1138	953	888	7	18	8	18	685	700	6.8	7.3
800	1153	1188	1003	938	8	20	8	18	785	800	7.1	7.6

## 5.1 External Dimensions



ST: Stroke, M.E.: Mechanical End, S.E.: Stroke End

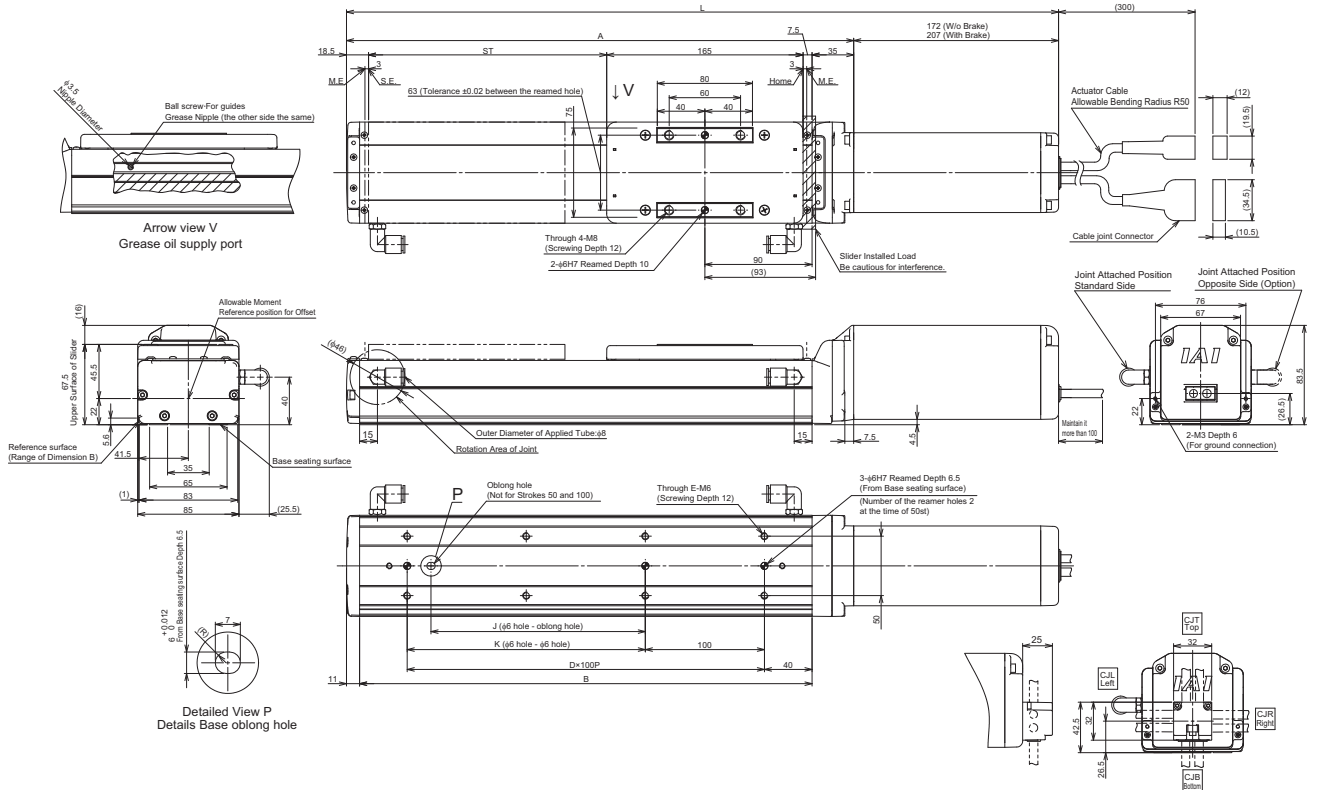

### ■ Dimensions and Mass by Stroke

Unit: mm

\* No pipe joint for slider roller type (SR)

Stroke	L		A	B	D	E	J	K	Mass [kg]	
	W/o Brake	With Brake							W/o Brake	With Brake
50	448	483	276	230	1	4	0	0	4.7	5.2
100	498	533	326	280	2	6	0	100	5.0	5.5
150	548	583	376	330	2	6	80	100	5.3	5.8
200	598	633	426	380	3	8	180	200	5.6	6.1
250	648	683	476	430	3	8	180	200	5.9	6.4
300	698	733	526	480	4	10	280	300	6.2	6.7
350	748	783	576	530	4	10	280	300	6.5	7.0
400	798	833	626	580	5	12	380	400	6.8	7.3
450	848	883	676	630	5	12	380	400	7.1	7.6
500	898	933	726	680	6	14	480	500	7.4	7.9
550	948	983	776	730	6	14	480	500	7.6	8.1
600	998	1033	826	780	7	16	580	600	7.9	8.4
650	1048	1083	876	830	7	16	580	600	8.2	8.7
700	1098	1133	926	880	8	18	680	700	8.5	9.0
750	1148	1183	976	930	8	18	680	700	8.8	9.3
800	1198	1233	1026	980	9	20	780	800	9.1	9.6
850	1248	1283	1076	1030	9	20	780	800	9.4	9.9
900	1298	1333	1126	1080	10	22	880	900	9.7	10.2
950	1348	1383	1176	1130	10	22	880	900	10.0	10.5
1000	1398	1433	1226	1180	11	24	980	1000	10.3	10.8
1050	1448	1483	1276	1230	11	24	980	1000	10.6	11.1
1100	1498	1533	1326	1280	12	26	1080	1100	10.8	11.3

# ROBO Cylinder

---

# Chapter 6

## Life

6.1	Concept of life for slider type .....	6-1
	How to calculate operation life .....	6-1
	Relation between operation life and moment .....	6-3

## 6.1 Concept of life for slider type

The mechanical life of the slider type is represented by that of the linear guide receiving the greatest moment load.

The operation life of the linear guide is to be determined by the total driving distance reachable without flaking (peeling on rail surface) in 90% of a group of products operated under the same conditions.

Operation life can be calculated with the method shown below.

### How to calculate operation life

For the operation life of the linear guide, use the dynamic allowable moment stated in "1.2 specifications", and calculate with the formula below.

$$L = \left( \frac{C_M}{M} \right)^3 \times 5,000\text{km}$$

L : Operation life (km)

$C_M$  : Dynamic allowable moment (N·m)

M : Moment acting (N·m)

5,000km : Standard rated life of ROBO Cylinder

In addition, calculate with the formula below if the life may be shortened due to vibration or mounting status.

$$L = \left( \frac{C_M}{M} \cdot \frac{f_{ws}}{f_w} \cdot \frac{1}{f_\alpha} \right)^3 \times 5,000\text{km}$$

L : Operation life (km)

$C_M$  : Dynamic allowable moment (N·m)

M : Moment acting (N·m)

5,000km: Standard rated life of ROBO Cylinder

$f_{ws}$  : Standard load coefficient

$f_w$  : Load coefficient

$f_\alpha$ : Mounting coefficient

For "Standard load coefficient  $f_{ws}$ ", "Load coefficient  $f_w$ " and "Mounting coefficient  $f_a$ ", refer to the contents below for configuration and selection.

**[Standard load coefficient  $f_{ws}$ ]**

For ROBO Cylinders described in this manual, calculate with  $f_{ws} = 1.2$ .

**[Load coefficient  $f_w$ ]**

This coefficient allows consideration of the effects on life due to operating conditions.

Load coefficient $f_w$	Operating conditions	Guideline for acceleration/deceleration
1.0 to 1.5	Low vibration/impact, slow operation	1.0G or less

**[Mounting coefficient  $f_a$ ]**

This coefficient allows consideration of the effects on life due to ROBO Cylinder mounting status.

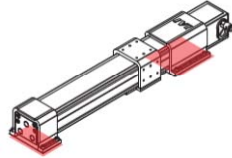
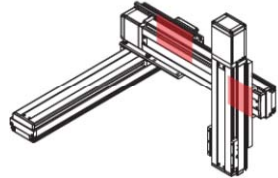
Mounting coefficient $f_a$	1.0	1.2	1.5
Mounting status	<p><b>Fixed on entire surface</b></p> 	<p><b>Fixed at both ends</b></p> 	<p><b>Fixed locally</b></p> 

- The actuator used in the explanatory figures above is not the RCS4 ROBO Cylinder. Replace with ROBO Cylinder and select the mounting coefficient.
- Even when seated over the total length of the product, select 1.2 or 1.5 for the mounting coefficient depending on the position of screw fixing and not "fixing over the entire surface".
- "Fixing over the entire surface" is considered to be the case only when fixing with the T-slot and square nut provided on the mounting surface.

### Relation between operation life and moment

---

The operation life depends on the moment acting on the slider.

With a light load, it may be longer than 5,000km, the standard rated life.

With no consideration of vibration and mounting conditions, the operation life is 40,000km according to the calculation with the formula on the previous page, assuming that 0.5 CM (half of dynamic allowable moment) of moment is applied.

We see that it can be 8 times longer than the standard rated life, which is 5,000km.



# ROBO Cylinder

---

# Chapter 7

## Warranty

7.1	Warranty period .....	7-1
7.2	Scope of the warranty .....	7-1
7.3	Honoring the warranty .....	7-1
7.4	Limited liability .....	7-2
7.5	Conformance with applicable standards/regulations, etc., and application conditions .....	7-2
7.6	Other Items excluded from warranty .....	7-2

## 7.1 Warranty period

### 7.1 Warranty period

Whichever of the following periods is shorter:

- 18 months after shipment from IAI
- 12 months after delivery to the specified location
- 2,500 hours of operation

### 7.2 Scope of the warranty

Our products are covered by warranty when all of the following conditions are met.

Faulty products covered by warranty will be replaced or repaired free of charge:

- (1) The breakdown or malfunction in question pertains to our product as delivered by IAI or our authorized dealer.
- (2) The breakdown or malfunction in question occurred during the warranty period.
- (3) The breakdown or malfunction in question occurred while the product was in use for an appropriate purpose under the operating conditions and operating environment specified in the instruction manual and catalog.
- (4) The breakdown or malfunction in question was caused by a specification defect, malfunction, or poor product quality.

Note that breakdowns due to any of the following reasons are excluded from the scope of warranty:

- (a) Anything other than our product
- (b) Modification or repair performed by a party other than IAI (unless approved by IAI)
- (c) Anything that could not be easily predicted with the level of science and technology available at the time of shipment from IAI
- (d) Natural disaster, unnatural disaster, incident or accident for which we are not liable
- (e) Natural fading of paint or other symptoms of aging
- (f) Wear, depletion or other expected result of use
- (g) Operation noise, vibration or other subjective sensations not affecting function or maintenance

Note that the warranty only covers our product as delivered and that any secondary loss arising from a breakdown of our product is excluded from the scope of warranty.

### 7.3 Honoring the warranty

As a rule, the product must be consigned to IAI for repair under warranty.

## 7.4 Limited liability

- (1) We assume no liability for any special damage, consequential loss or passive loss such as a loss of expected profit arising from or in connection with our product.
- (2) We assume no liability for any program or control method created by the customer to operate our product or for the results of any such program or control method.

## 7.5 Conformance with applicable standards/regulations, etc., and application conditions

- (1) If our product is combined with another product or any system, equipment, etc., used by the customer, the customer must first check the applicable standards, regulations and/or rules. The customer is also responsible for confirming that such combination with our product conforms to the applicable standards, etc.  
In such a case we assume no liability for the conformance of our product with the applicable standards, etc.
- (2) Our product is for general industrial use. It is not intended or designed for the applications specified below, which require a high level of safety. Accordingly, as a rule our product cannot be used in these applications.  
Contact IAI if you must use our product for any of these applications:
  - (a) Medical equipment used to maintain, control or otherwise affect human life or physical health
  - (b) Mechanisms and machinery designed for the purpose of moving or transporting people (vehicles, railway facilities, aviation facilities etc.)
  - (c) Machinery components essential for safety (safety devices etc.)
  - (d) Equipment used to handle cultural assets, art or other irreplaceable items
- (3) Contact IAI in advance if our product is to be used in any condition or environment that differs from that specified in the catalog or instruction manual.

## 7.6 Other Items excluded from warranty

The price of the product delivered to you does not include expenses associated with programming, the dispatch of engineers, etc. Accordingly, a separate fee will be charged in the following cases even during the warranty period:

- (1) Guidance for mounting/adjustment and witnessing of test operation
- (2) Maintenance and inspection
- (3) Technical guidance and education on operating/wiring methods, etc.
- (4) Technical guidance and education on programming and other items related to programs



## 7. Warranty

---

# ROBO Cylinder

---

# Chapter 8

## Appendix

8.1	Index	8-1
8.2	Revision history	8-3

**8.1 Index****A**

Allowable moment ..... 1-6, 1-9,  
1-12, 1-15, 1-18, 1-21, 1-24, 1-27, 1-28

Ambient operating temperature ..... 1-6, 1-9,  
1-12, 1-15, 1-18, 1-21, 1-24, 1-27

**B**

Belt replacement/adjustment ..... 4-19 to 23

**C**

Cable Exit Direction Changed (Model Code:  
CJT, CJR, CJL, CJB and CJO) ..... 1-31

Cleaning ..... 4-7

**D**

Double Slider Specification  
(Model Code: W) ..... 1-32

Duty ratio ..... 1-29

**E**

Encoder Cable ..... 1-36

## External Dimensions

RCS4-SA4C ..... 5-1

RCS4-SA6C ..... 5-2

RCS4-SA7C ..... 5-3

RCS4-SA8C ..... 5-4

RCS4-SA4R ..... 5-5

RCS4-SA6R ..... 5-7

RCS4-SA7R ..... 5-8

RCS4-SA8R ..... 5-10

RCS4CR-SA4C ..... 5-12

RCS4CR-SA6C ..... 5-13

RCS4CR-SA7C ..... 5-14

RCS4CR-SA8C ..... 5-15

External visual inspection ..... 4-4

**G**

Grease used ..... 4-8 to 9

Greasing method ..... 4-8 to 12

**H**

High Precision Specifications  
(Model Code: HPR) ..... 1-31

How to Read the Model Nameplate ..... 1-2

How to Read the Model Number ..... 1-2

**I**

Inspection Items and Schedule ..... 4-3

Installation Environment ..... 2-3

Installation of the Main Unit ..... 2-8 to 15

Installation Orientation ..... 2-5

Installation surface ..... 2-7

Internal Cleaning ..... 4-7

Internal visual inspection ..... 4-5 to 6

International Standard Compliance ..... Intro-10

**L**

Life ..... 6-1 to 3

**M**

## Mass

RCS4-SA4C ..... 5-1

RCS4-SA6C ..... 5-2

RCS4-SA7C ..... 5-3

RCS4-SA8C ..... 5-4

RCS4-SA4R ..... 5-5

RCS4-SA6R ..... 5-7

RCS4-SA7R ..... 5-8

RCS4-SA8R ..... 5-10

RCS4CR-SA4C ..... 5-12

RCS4CR-SA6C ..... 5-13

RCS4CR-SA7C ..... 5-14

RCS4CR-SA8C ..... 5-15

Max Speed ..... 1-3, 1-4,  
1-7, 1-10, 1-13, 1-16, 1-19, 1-22, 1-25

Max. Payload ..... 1-3, 1-4,  
1-7, 1-10, 1-13, 1-16, 1-19, 1-22, 1-25

Motor Cable ..... 1-35

Motor Replacement ..... 4-24 to 31

## Motor Reversed Direction

(Model Code: ML, MR) ..... 1-31

Mounting transported objects ..... 2-16 to 18

**N**

## Names of the Parts

Standard Type Motor Straight Type ..... Intro-11

Standard Type Motor Reversing Type ..... Intro-11

Cleanroom Type Motor Straight Type ..... Intro-12

No. of Encoder Pulses ..... 1-6, 1-9,  
1-12, 1-15, 1-18, 1-21, 1-24, 1-27

## P

- Parts ..... 1-1
- Payload ..... 1-3, 1-4 to 5,  
1-7 to 8, 1-10 to 11, 1-13 to 14, 1-16 to 17,  
1-19 to 20, 1-22 to 23, 1-25 to 26
- Positioning Repeatability ..... 1-3, 1-6,  
1-9, 1-12, 1-15, 1-18, 1-21, 1-24, 1-27
- Precautions for Handling ..... Intro-9 to 10
- Precautions for transportation ..... 2-1 to 2
- Product list ..... 1-3

## R

- Rear Attachment Plate  
(Model Code: RP) ..... 1-32
- Reversed-home Specification  
(Model Code: NM) ..... 1-31

## S

- Slider Roller Specification  
(Model Code: SR) ..... 1-32
- Speed ..... 1-3, 1-4,  
1-7, 1-10, 1-13, 1-16, 1-19, 1-22, 1-25
- Stainless steel sheet replacement/adjustment  
..... 4-13 to 18
- Storage/preservation environment ..... 2-4

## V

- Vacuum Joint Attachment Opposite Type  
(Model Code: VR) ..... 1-32

## W

- Warranty ..... 7-1 to 2
- With brake (Model Code: B) ..... 1-31

**8.2 Revision history**

Revision date	Revised content
2017.10	First Edition







## ***IAI Corporation***

Head Office: 577-1 Obane Shimizu-KU Shizuoka City Shizuoka 424-0103, Japan  
TEL +81-54-364-5105 FAX +81-54-364-2589  
website: [www.iai-robot.co.jp/](http://www.iai-robot.co.jp/)

Technical Support available in USA, Europe and China

## ***IAI America, Inc.***

Head Office: 2690 W. 237th Street, Torrance, CA 90505  
TEL (310) 891-6015 FAX (310) 891-0815  
Chicago Office: 110 East State Parkway, Schaumburg, IL 60173  
TEL (847) 908-1400 FAX (847) 908-1399  
Atlanta Office: 1220 Kennestone Circle, Suite 108, Marietta, GA 30066  
TEL (678) 354-9470 FAX (678) 354-9471  
website: [www.intelligentactuator.com](http://www.intelligentactuator.com)

## ***IAI Industrieroboter GmbH***

Ober der Röth 4, D-65824 Schwalbach am Taunus, Germany  
TEL 06196-88950 FAX 06196-889524

## ***IAI (Shanghai) Co., Ltd.***

SHANGHAI JIAHUA BUSINESS CENTER A8-303, 808, Hongqiao Rd. Shanghai 200030, China  
TEL 021-6448-4753 FAX 021-6448-3992  
website: [www.iai-robot.com](http://www.iai-robot.com)

## ***IAI Robot (Thailand) Co., Ltd.***

825, PhairojKijja Tower 12th Floor, Bangna-Trad RD., Bangna, Bangkok 10260, Thailand  
TEL +66-2-361-4458 FAX +66-2-361-4456