

**CURTISS -
WRIGHT**

FTP Series Product Catalog

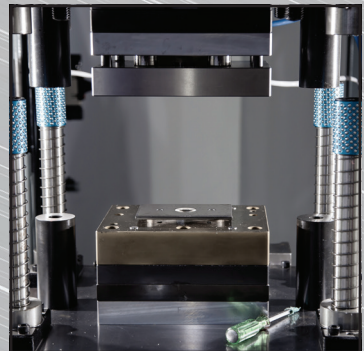
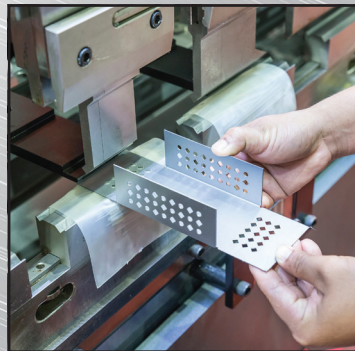
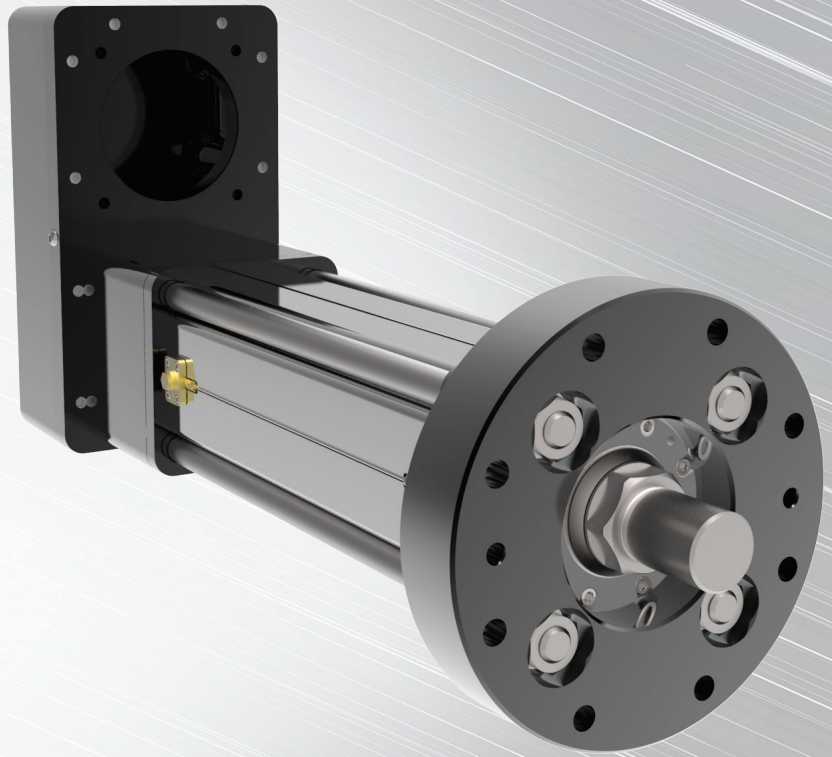

FTP Series

HIGH FORCE ELECTRIC PRESS ACTUATOR

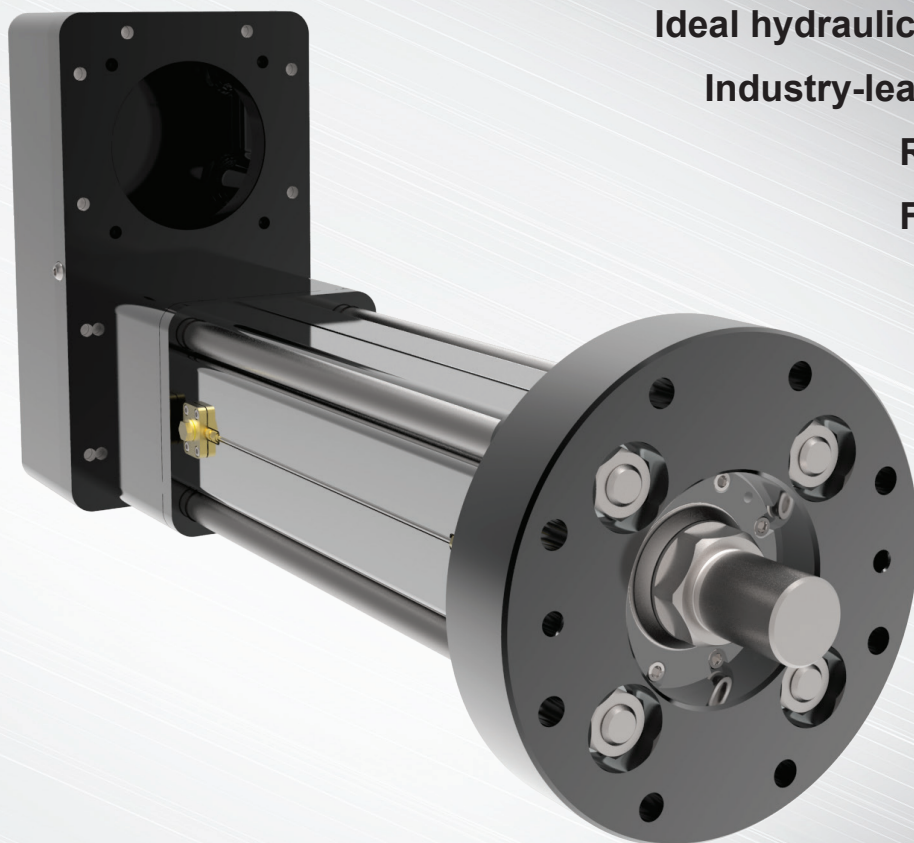

Ideal hydraulic press replacement

Industry-leading power density

Rugged and reliable

Flexible and precise

FTP Series

High Force Electric Press Actuators

Hydraulic Press Replacement

Based on planetary rollers screw technology, the FTP Series high force electric press actuators were designed to provide very high force in a small package size making them an ideal alternative to hydraulic cylinders in pressing applications. The FTP offers force density not attainable with more common ball screw based electric actuators, up to 15X the life and 2X the force density in most cases.

Programmable and Accurate

Attaining any kind of accuracy with a traditional hydraulic solution requires complicated servo valves that are difficult to set up and need frequent adjustment for optimum performance. Once set, changeover to a different part or mode of operation is equally as troublesome. The all-electric FTP Series utilizes commonly understood servo motor technology, offering accuracy, control and flexibility not available with hydraulics.

Reliable and Efficient

The FTP Series high force electric press actuators allow machine builders to meet the ever-increasing performance demands of their customers while minimizing or eliminating the maintenance issues and downtime associated with traditional hydraulic solutions. Their programmability and flexibility significantly reduces changeover time between production runs enabling smaller batch sizes, and they typically consume 25% less energy than a typical hydraulic solution. Increase your operational efficiency today by switching to the FTP Series.

Operating Conditions and Usage		
Accuracy:		
Screw Travel Variation	mm (in)	0.030 (0.0012)
Screw Lead Error	mm/300 mm (in/ft)	0.025 (0.001)
Screw Lead Backlash	mm (in)	0.06 (0.002)
Ambient Conditions:		
Standard Ambient Temperature	°C	0° to 85°
IP Rating		IP65S

Product Features

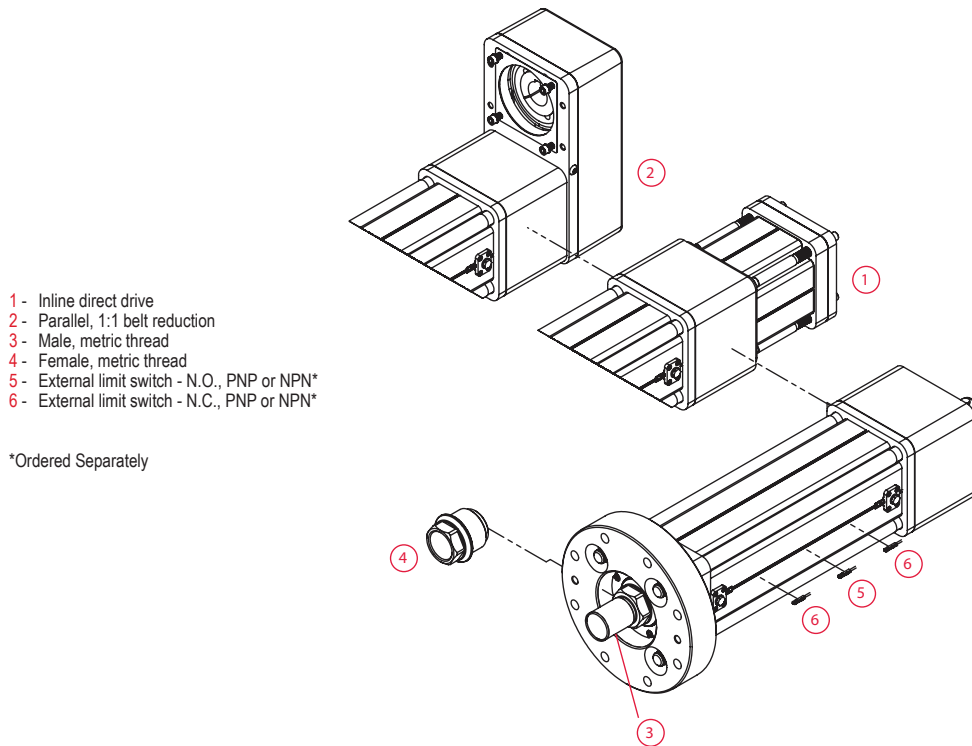
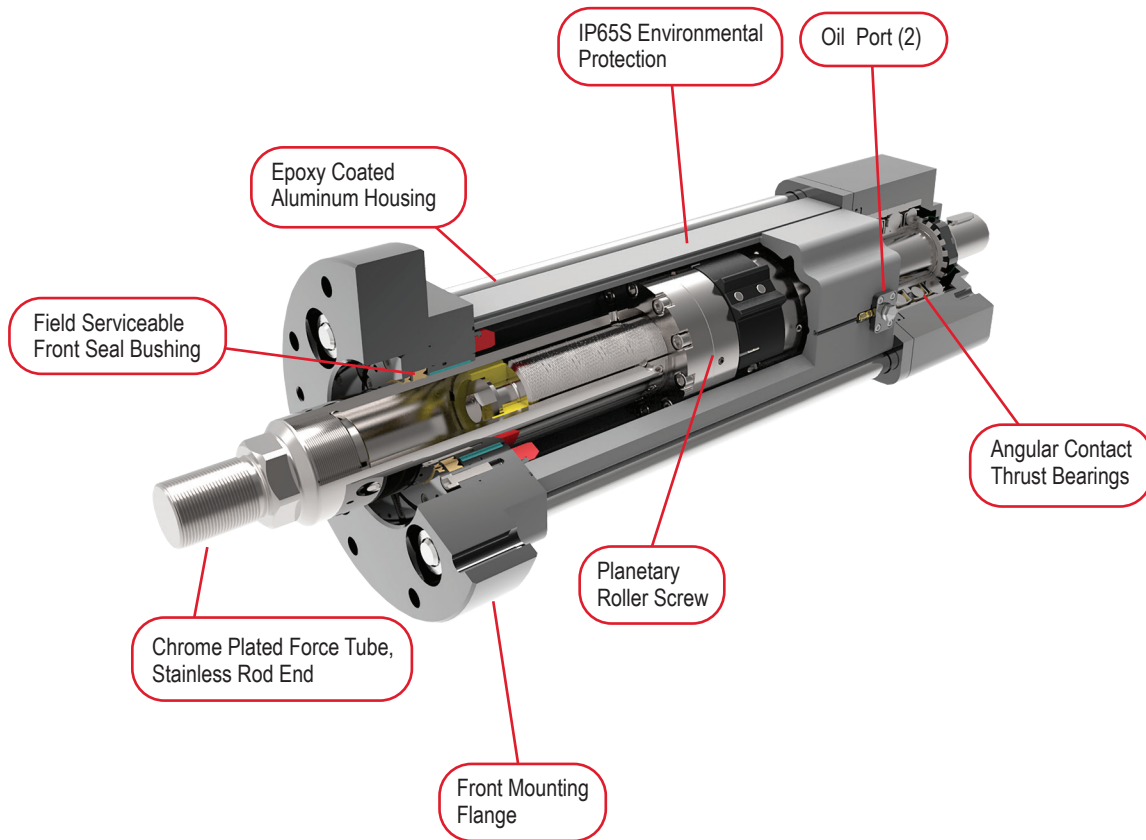

Mechanical Specifications

FTP160

		12
Screw Lead	mm	12
	in	0.472
Maximum Force (Extension)	kN	200.0
	lbf	45,000
Maximum Force (Retraction)	kN	89.0
	lbf	20,000
Life at Maximum Force (Minimum)	Press Cycles	3 Million
Maximum Full Load Press Stroke	mm	12
	in	0.47
C _a (Dynamic Load Rating)	kN	290.0
	lbf	65,200
Maximum Input Torque	Nm	472
	lbf-in	4,225
Max Rated RPM @ Input Shaft	RPM	2,000
Maximum Linear Speed @ Maximum Rated RPM	mm/sec	401
	in/sec	15.8
Friction Torque (Typical)	Nm	4.54
	lbf-in	40

Weights kg (lbs)

Base Actuator Weight (Zero Stroke)	kg	56
	lb	124
Actuator Weight Adder (Per 25 mm of stroke)	kg	1.73
	lb	3.8
Adder for Inline (excluding motor)	kg	14.2
	lb	30.7
Adder for Parallel Drive (excluding motor)	kg	53.1
	lb	117.8
Adder for Front Flange	kg	19.0
	lb	41.7

Base Unit Inertia		Zero Stroke [kg-m ² (lbf-in-sec ²)]	Add per 25 mm [kg-m ² (lbf-in-sec ²)]
12 mm Lead		1.35 x 10 ⁻² (1.20 x 10 ⁻¹)	2.58 x 10 ⁻⁴ (2.28 x 10 ⁻³)
Inline Drive Inertia	Inline Unit - w/Motor Coupling	Inline Unit - w/Motor Coupling For Gearbox Mount	Add per 25 mm
12 mm Lead	1.47 x 10 ⁻² (1.30 x 10 ⁻¹)	1.68 x 10 ⁻² (1.49 x 10 ⁻¹)	2.58 x 10 ⁻⁴ (2.28 x 10 ⁻³)
Parallel Drive Inertia		1:1 Reduction	Add per 25 mm
12 mm Lead (zero stroke)		5.28 x 10 ⁻² (4.67 x 10 ⁻¹)	2.58 x 10 ⁻⁴ (2.28 x 10 ⁻³)

FTP215

		12
Screw Lead	mm	12
	in	0.472
Maximum Force (Extension)	kN	355.8
	lbf	80,000
Maximum Force (Retraction)	kN	177.9
	lbf	40,000
Life at Maximum Force (Minimum)	Press Cycles	1.6 Million
Maximum Full Load Press Stroke	mm	12
	in	0.47
C _a (Dynamic Load Rating)	kN	423.5
	lbf	95,200
Maximum Input Torque	Nm	850
	lbf-in	7,520
Max Rated RPM @ Input Shaft	RPM	1,750
Maximum Linear Speed @ Maximum Rated RPM	mm/sec	351
	in/sec	13.8
Friction Torque (Typical)	Nm	5.65
	lbf-in	50

Weights kg (lbs)

Base Actuator Weight (Zero Stroke)	kg	127
	lb	280
Actuator Weight Adder (Per 25 mm of stroke)	kg	2.7
	lb	5.96
Adder for Inline (excluding motor)	kg	38.6
	lb	85.1
Adder for Parallel Drive (excluding motor)	kg	62.3
	lb	137.35
Adder for Front Flange	kg	46.5
	lb	102.5

Base Unit Inertia		Zero Stroke [kg-m ² (lbf-in-sec ²)]	Add per 25 mm [kg-m ² (lbf-in-sec ²)]
12 mm Lead		4.26 x 10 ⁻² (3.77 x 10 ⁻¹)	8.02 x 10 ⁻⁴ (7.10 x 10 ⁻³)
Inline Drive Inertia	Inline Unit - w/Motor Coupling	Inline Unit - w/Motor Coupling For Gearbox Mount	Add per 25 mm
12 mm Lead	4.44 x 10 ⁻² (3.93 x 10 ⁻¹)	6.16 x 10 ⁻² (5.45 x 10 ⁻¹)	8.02 x 10 ⁻⁴ (7.10 x 10 ⁻³)
Parallel Drive Inertia		1:1 Reduction	Add per 25 mm
12 mm Lead (zero stroke)		9.43 x 10 ⁻² (8.34 x 10 ⁻¹)	8.02 x 10 ⁻⁴ (7.10 x 10 ⁻³)

Data Curves

Estimated Service Life

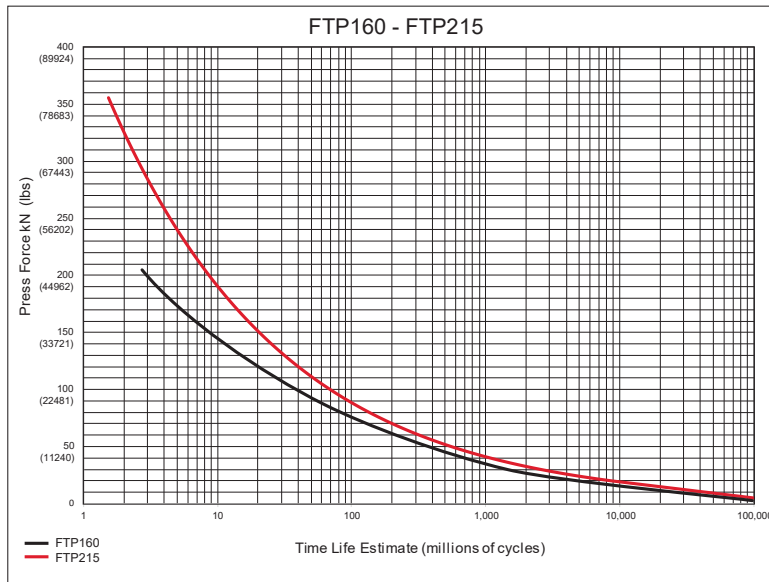

The underlying formula that defines this value is:

L_{10} = Lifetime estimate in millions of cycles, where:

C_a = Dynamic load rating (lbf)

F_{press} = Press force (press distance \leq 12mm)

$$L_{10} = \left(\frac{C_a}{F_{press}} \right)^3$$

Service Life Estimate Assumptions:

- Sufficient quality and quantity of lubrication is maintained throughout service life
- Bearing and screw temperature between 20° C and 40° C
- No mechanical hard stops (external or internal) or impact loads
- No external side loads

FTP Press Sizing Guide

Exlar's FTP series actuators meet the most demanding pressing applications in the market. Successful applications include bearing press, stamping, and leak testing. Due to design considerations for the FTP series, the extreme forces are only achievable when extending the main rod. See manufacturer's specifications on page 70 for maximum force ratings for each actuator in the FTP series.

For any press force less than the maximum rating, calculate the estimated L_{10} life by using the calculation method listed. The press distance must not exceed the maximum rated press distance listed.

If your application is outside the specifications, please fill in the following table and chart. Send the completed document to cha_applications@curtisswright.com. Exlar's sales engineering team will review the application to determine if Exlar has a solution to meet the requirements.

Required Data for Press Applications Outside Listed Specifications

Application Data		
Typical Press Force	kN	
Typical Press Stroke	mm	
Maximum Press Force	kN	
Maximum Press Stroke	mm	
Cycle Rate	Cycles/min	
Dwell Time After Each Cycle	s	
Life Expectancy	Months	

Sketch Profile of Typical Cycle

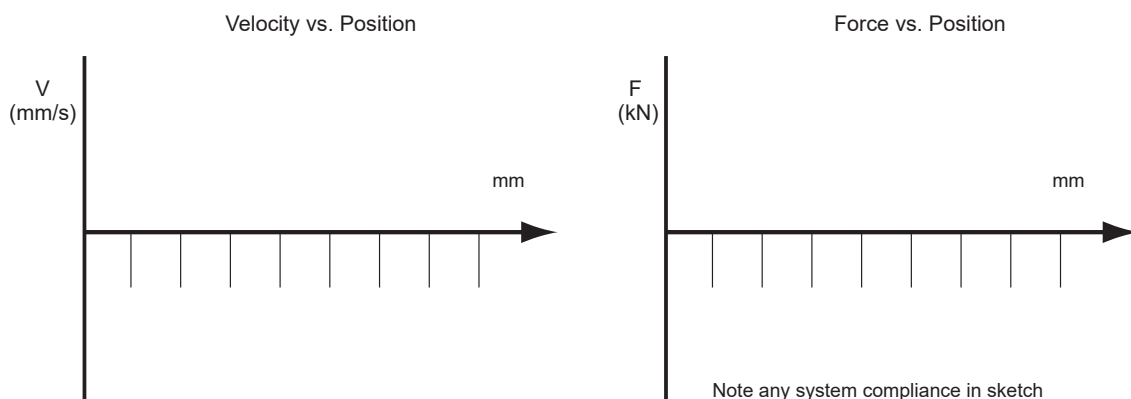

Dimensions

FTP160 BASE ACTUATOR

ALL DIMENSIONS IN MILLIMETERS

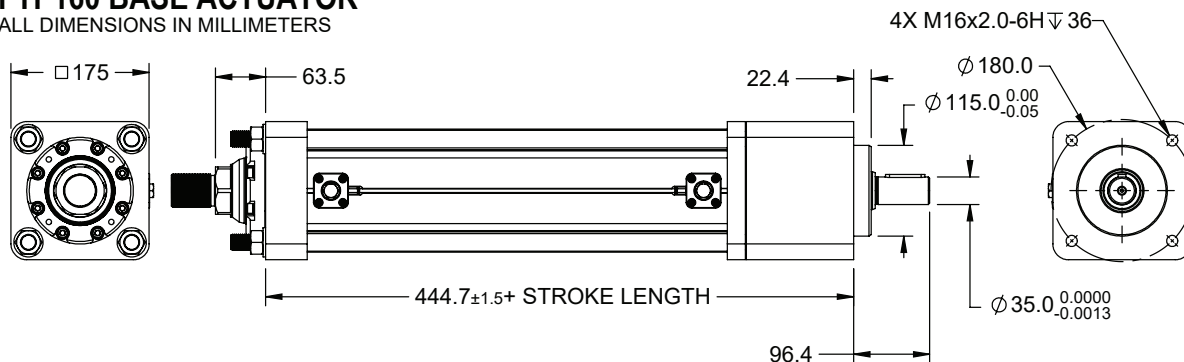

1 (FRONT FLANGE)

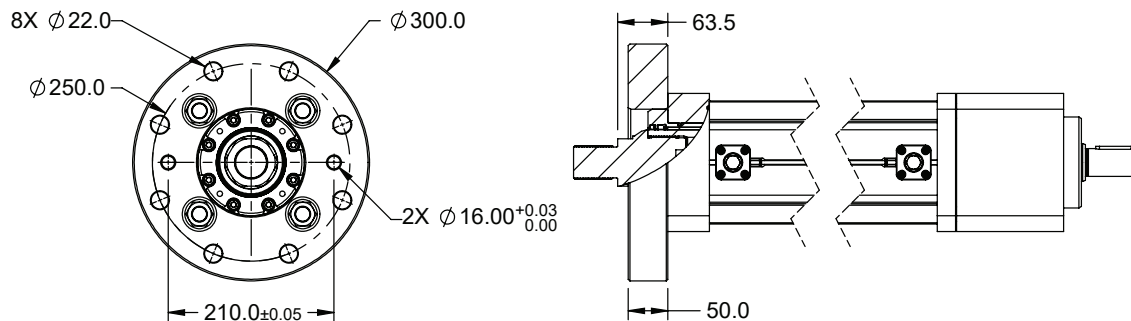

N10 (INLINE MOUNT)

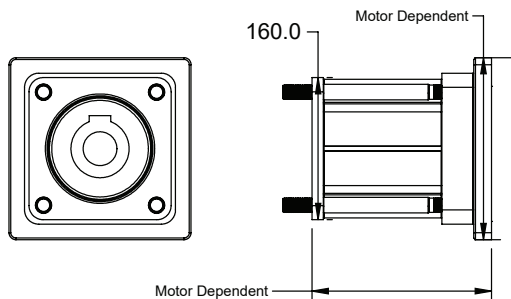

P10 (PARALLEL MOUNT)

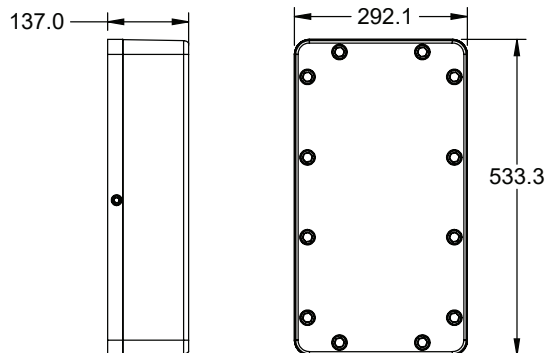

ROD ENDS

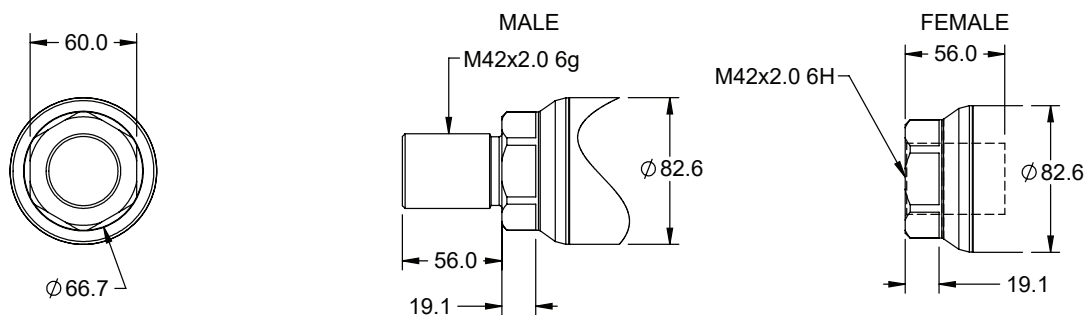

FTP215 BASE ACTUATOR
ALL DIMENSIONS IN MILLIMETERS

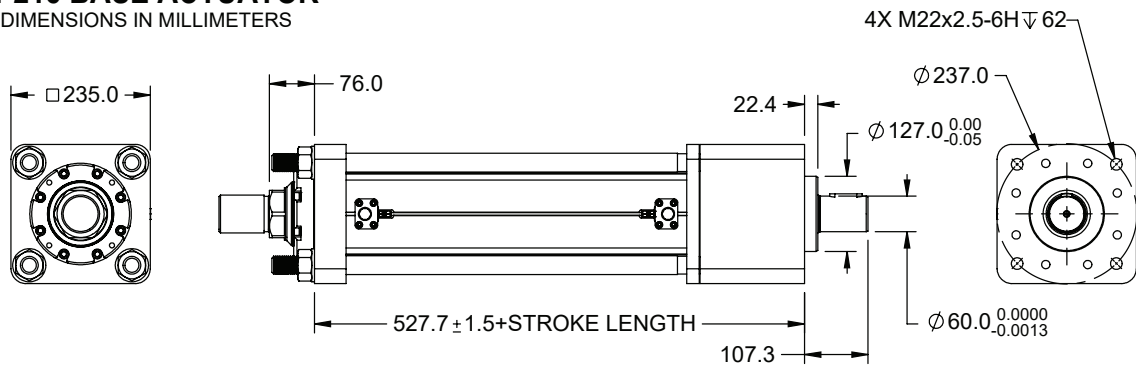

1 (FRONT FLANGE)

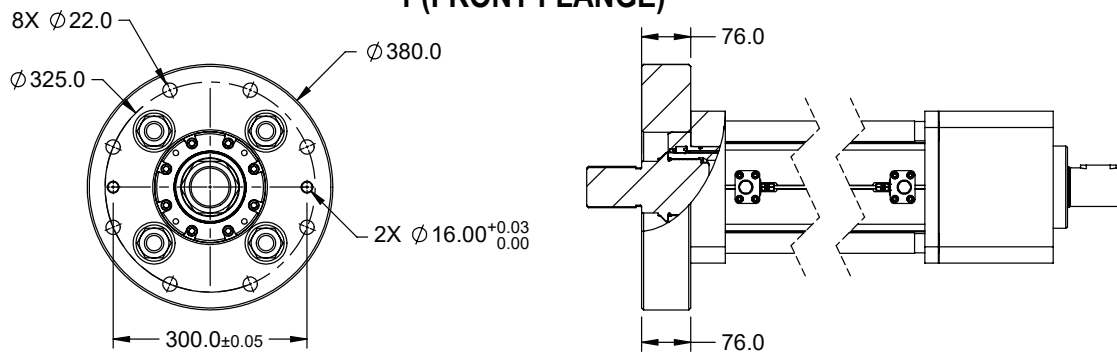

N10 (INLINE MOUNT)

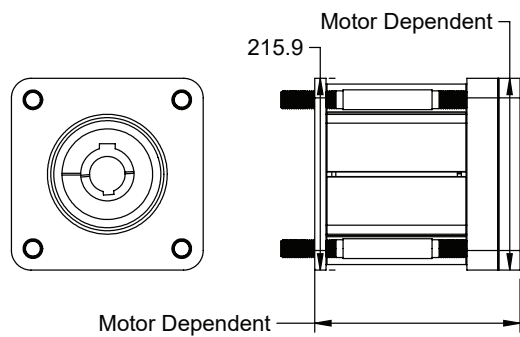

P10 (PARALLEL MOUNT)

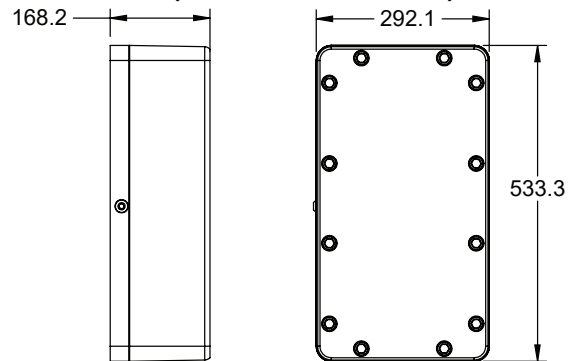

ROD ENDS

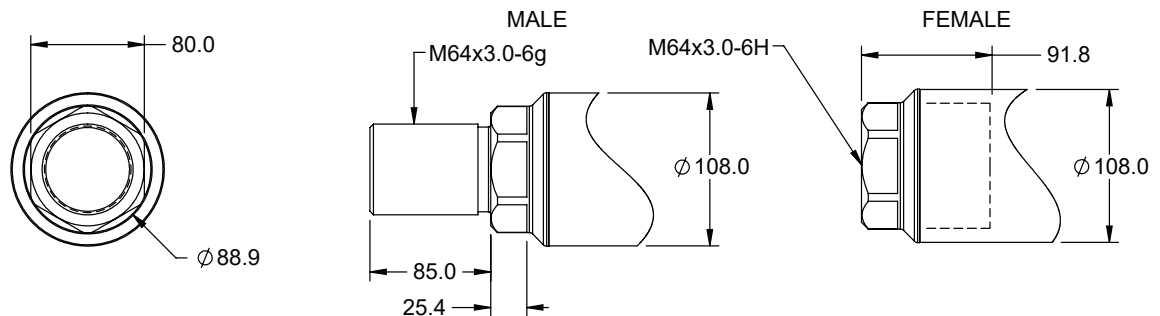

Case Dimensions

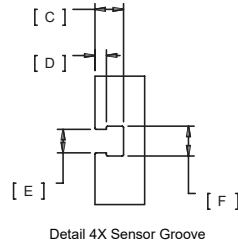
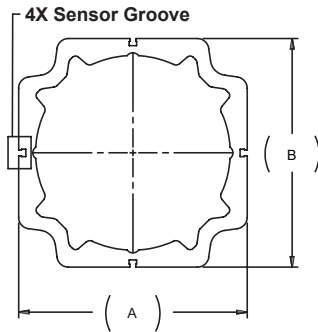

		A	B	C	D	E	F
FTP160	mm	156	156	5.5	1.7	5.3	6.6
	in	6.1	6.1	0.22	0.07	0.21	0.26
FTP215	mm	203	203	6.4	2.5	5.2	6.6
	in	8.0	8.0	0.25	0.10	0.21	0.26

Standard Gearbox Mount Codes for the FTP

FTP160 Gearbox Mounts								
None		Inline				Parallel 1:1		
		Dimension in mm						
Motor Flange Code		Motor Flange Code		Bolt Circle	Pilot Diam.	Motor Flange Code		Pilot Diam.
NMT-	00	N10-	19	165	130	P10-	19	165
		N10-	22	215	160	P10-	22	215
Motor Shaft Code		Motor Shaft Code		Shaft Diam.	Key Width	Motor Shaft Code		Key Width
	00		QA	40	12		QA	12
			UA	55	16		UA	16
Shaft Length		Shaft Length				Shaft Length		
	000	080, 082, 085, 088, 097, 100, 105, 110, 112, 113, 116		* Pick closest shaft length within 2mm if your exact length is not listed		060-124		* Allowable shaft length range in 1 mm increments

FTP215 Gearbox Mounts								
None		Inline				Parallel 1:1		
		Dimension in mm						
Motor Flange Code		Motor Flange Code		Bolt Circle	Pilot Diam.	Motor Flange Code		Pilot Diam.
NMT-	00	N10-	19	165	130	P10-	19	165
		N10-	22	215	160	P10-	22	215
		N10-	27	250	180	P10-	27	250
Motor Shaft Code		Motor Shaft Code		Shaft Diam.	Key Width	Motor Shaft Code		Key Width
	00		QA	40	12		QA	12
			UA	55	16		UA	16
			XA	75	20		XA	20
Shaft Length		Shaft Length				Shaft Length		
	000	080, 082, 085, 097, 100, 102, 105, 110, 112, 116, 140		* Pick closest shaft length within 2mm if your exact length is not listed		070-155		* Allowable shaft length range in 1 mm increments

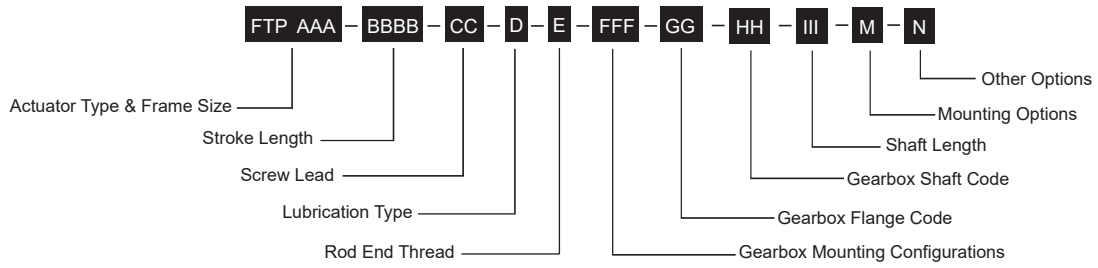

AAA = Frame Size

160 = 160 mm
215 = 215 mm

BBBB = Stroke Length

0150 = 150 mm
0300 = 300 mm
0600 = 600 mm
0900 = 900 mm (FTP160 only)

CC = Screw Lead

12 = 12 mm

D = Lubrication Type

2 = Oil

E = Rod End Thread

A = Male, Metric
B = Female, Metric

FFF = Motor Mounting Configurations¹

NMT = None, base unit only
N10 = Inline, includes shaft coupling
P10 = Parallel, 1:1 belt reduction

GG = Motor/Gearbox Flange Code

See standard gearbox mounting code dimension sheet

HH = Motor Shaft Code

See standard gearbox mounting code dimension sheet

III = Shaft Length

See standard gearbox mounting code dimension sheet

M = Mounting Option

1 = Front Flange, Metric (Required)

N = Other Options

N = None

NOTES:
1. Always discuss your motor selection with your local sales representative.

FTP Series Accessories

Limit Switches	
Part Number	Description
43403	Normally Open PNP Limit Switch (10-30 VDC, 1m. 3 wire embedded cable)
43404	Normally Closed PNP Limit Switch (10-30 VDC, 1m. 3 wire embedded cable)
67634	Normally Open NPN Limit Switch (10-30 VDC, 1m. 3 wire embedded cable)
67635	Normally Closed NPN Limit Switch (10-30 VDC, 1m. 3 wire embedded cable)



For options or specials not listed above, please contact Exlar

1. **OFFER AND ACCEPTANCE:** These terms and conditions constitute Seller's offer to Buyer and acceptance by Buyer and any resulting sale is expressly limited to and conditioned upon Seller's terms and conditions as set forth below. If Buyer objects to any of Seller's terms and conditions, such objections must be expressly stated and brought to the attention of Seller in a written document which is separate from any purchase order or other printed form of Buyer. Such objections, or the incorporation of any additional or different terms or conditions by Buyer into a resulting order shall constitute non-acceptance of these Terms and Conditions, releasing Seller from any obligation or liability hereunder and a proposal for different terms and conditions which shall be objected to by Seller unless expressly accepted in writing by an authorized representative of Seller. Acknowledgment copy, if any, shall not constitute acceptance by Seller of any additional or different terms or conditions, nor shall Seller's commencement of effort, in itself, be construed as acceptance of an order containing additional or different terms and conditions.

2. **PRICES:** Published prices and discount schedules are subject to change without notice. They are prepared for the purpose of furnishing general information and are not quotations or offers to sell on the part of the company.

3. **TRADE TERMS:** Shipment terms are FCA, shipping point (Exlar, Chanhassen, MN). FCA (Free Carrier) per Incoterms 2010 means the Seller delivers the goods, cleared for export into the custody of the first carrier named by the buyer at the named place, above. This term is suitable for all modes of transport, including carriage by air, rail, road, and containerized/multi-modal transport. Title of the merchandise transfers from Exlar Corporation to the Buyer when it is received from Exlar by the carrier. Where allowable, Exlar will arrange the transportation via the carrier specified by the Buyer. The Buyer is responsible for all costs associated with the shipment.

4. **PAYMENT TERMS:** Subject to approval of Buyer's credit, the full net amount of each invoice is due and payable in cash within thirty (30) days of shipment. No payment discounts are offered, and minor inadvertent administrative errors contained in an invoice are subject to correction and shall not constitute reason for untimely payment. If, in the judgment of the Seller, the financial credit of Buyer at any time does not justify continuance of production or shipment of any product(s) on the payment terms herein specified, Seller may require full or partial payment prior to completion of production or shipment, or may terminate any order, or any part thereof, then outstanding. Custom products and blanket orders are subject to payment terms: 30% due at time of order, 70% due net 30 days from shipment.

5. **MINIMUM BILLING:** Minimum billing will be \$50.00.

6. **DELAYS:** Exlar shall not be liable for any defaults, damages or delays in fulfilling any order caused by conditions beyond Seller's control, including but not limited to acts of God, strike, lockout, boycott, or other labor troubles, war, riot, flood, government regulations, or delays from Seller's subcontractors or suppliers in furnishing materials or supplies due to one or more of the foregoing clauses.

7. **CANCELLATIONS:** All cancelled orders for standard products are subject to order cancellation charges. The minimum cancellation charge will be 20% of the order total. Standard products, if unused may be returned in accordance with the current return policy. All returns are subject to prior approval by Exlar, and return charges may apply. No return credit for any product will be issued or authorized prior to evaluation of the product by Exlar. Custom product is not returnable. Orders for custom product are not cancelable.

8. **QUANTITY PRICING AND BLANKET ORDER PRICING TERMS:** Blanket order pricing requires a complete delivery schedule for the volume being ordered, with all units scheduled to deliver within a 15 month period from the placement of the purchase order to the final scheduled shipment. Any requests to change the delivery schedule of a blanket order must be received in writing 60 days prior to the requested change. Failure to take delivery of the entire ordered volume will result in back charges equal to the difference in quantity price between the volume ordered and the volume received times the number of units received. A cancellation charge in accordance with the cancellation policy (item 7) will apply to any reduction in delivered volume from the original ordered quantity.

For orders receiving quantity discounts, but not as scheduled blanket orders, the same quantity pricing rules apply. Failure to take delivery of the entire quantity ordered will result in back charges equal to the difference in quantity price between the volume ordered and the volume received times the number of units received. Cancellation charges in accordance with the cancellation policy (item 7) will apply to any reduction in delivered volume from the original ordered quantity. For either blanket orders or quantity orders, in addition to any applicable cancellation charges, the customer is responsible for the value of any additional inventory allocated specifically to their order. Charges for this inventory will be invoiced in addition to cancellation charges, along with any back charges for quantity variance.

9. **DESTINATION CONTROL STATEMENT:** Exlar products, technology or software are exported from the United States in accordance with the Export Administration Regulations (EAR) or International Traffic in Arms Regulations (ITAR) as applicable. Diversion, transfer, transshipment or disposal contrary to U.S. law is prohibited.

10. **EXPORT CONTROL AND SHIPMENT REGULATIONS:** Purchaser agrees at all times to comply with all United States laws and regulations as well as International Trade Laws, as they may exist from time to time, regarding export licenses or the control or regulation of exportation or re-exportation of products or technical data sold or supplied to Distributor. Seller may terminate or suspend this order, without remedy, should the Purchaser become an entity identified on any US export denial listing. Products ordered may require authorization and/or validated export license from a U.S. government agency. Seller may terminate or suspend this order, without remedy, should a government agency approval be denied.

11. **GOVERNING LAW AND VENUE:** This order shall be governed by, and construed in accordance with the laws of the State of Minnesota, U.S.A. All disputes shall be resolved by a court of competent jurisdiction in the trial courts of Carver County, in the State of Minnesota.

12. **ATTORNEY FEES:** Reasonable attorney's fees and other expenses of litigation must be awarded to the prevailing party in an action in which a remedy is sought under this order.

13. **NON-WAIVER:** The failure by the Seller to require performance of any provision shall not affect the Seller's right to require performance at any time thereafter, nor shall a waiver of any breach or default of this Order constitute a waiver of any subsequent breach or default or a waiver of the provision itself.

14. **MERGER AND INTEGRATION:** These Terms and Conditions contain the entire agreement of the parties with respect to the subject matter of this order, and supersede all prior negotiations, agreements and understandings with respect thereto. Purchase orders may only be amended by a written document duly executed by buyer and seller.

15. **INDEMNITY:** Buyer agrees to indemnify, defend and hold harmless Exlar from any claims, loss or damages arising out of or related to Seller's compliance with Buyer's designs, specifications or instructions in the furnishing of products to Buyer, whether based on infringement of patents, copyrights, trademark or other right of others, breach of warranty, negligence, or strict liability or other tort.

WARRANTY AND LIMITATION OF LIABILITY: Products are warranted for two years from date of manufacture as determined by the serial number on the product label. Labels are generated and applied to the product at the time of shipment. The first and second digits are the year and the third and fourth digits represent the manufacturing week. Product repairs are warranted for 90 days from the date of the repair. The date of repair is recorded within the Exlar database and tracked by individual product serial number.

Exlar Corporation warrants its product(s) to the original purchaser and in the case of original equipment manufacturers, to their original customer to be free from defects in material and workmanship and to be made only in accordance with Exlar standard published catalog specifications for the product(s) as published at the time of purchase. Warranty or performance to any other specifications is not covered by this warranty unless otherwise agreed to in writing by Exlar and documented as part of any and all contracts, including but not limited to purchase orders, sales orders, order confirmations, purchase contracts and purchase agreements. In no event shall Exlar be liable or have any responsibility under such warranty if the product(s) has been improperly stored, installed, used or maintained, or if Buyer has permitted any unauthorized modifications, adjustments and/or repairs to such product(s). Seller's obligation hereunder is limited solely to repairing or replacing (at its option), at the factory any product(s), or parts thereof, which prove to Seller's satisfaction to be defective as a result of defective materials, or workmanship and within the period of time, in accordance with the Seller's stated product warranty (see Terms and Conditions above), provided, however, that written notice of claimed defects shall have been given to Exlar within thirty (30) days from the date of any such defect is first discovered. The product(s) claimed to be defective must be returned to Exlar, transportation prepaid by Buyer, with written specification of the claimed defect. Evidence acceptable to Exlar must be furnished that the claimed defects were not caused by misuse, abuse, or neglect by anyone other than Exlar.

Components such as seals, wipers, bearings, brakes, bushings, gears, splines, and roller screw parts are considered wear parts and must be inspected and serviced on a regular basis. Any damage caused by failure to properly lubricate Exlar products and/or to replace wear parts at appropriate times, is not covered by this warranty. Any damage due to excessive loading is not covered by this warranty.

The use of products or components under load such that they reach the end of their expected life is a normal characteristic of the application of mechanical products. Reaching the end of a product's expected life does not indicate any defect in material or workmanship and is not covered by this warranty.

Costs for shipment of units returned to the factory for warranty repairs are the responsibility of the owner of the product. Exlar will return ship all warranty repairs or replacements via UPS Ground at no cost to the customer.

For international customers, Exlar will return ship warranty repairs or replacements via UPS Expedited Service and cover the associated shipping costs. Any VAT or local country taxes are the responsibility of the owner of the product.

The foregoing warranty is in lieu of all other warranties (except as Title), whether expressed or implied, including without limitation, any warranty of merchantability, or of fitness for any particular purpose, other than as expressly set forth and to the extent specified herein, and is in lieu of all other obligations or liabilities on the part of Exlar.

Seller's maximum liability with respect to these terms and conditions and any resulting sale, arising from any cause whatsoever, including without limitation, breach of contract or negligence, shall not exceed the price specified of the product(s) giving rise to the claim, and in no event shall Exlar be liable under this warranty otherwise for special, incidental or consequential damages, whether similar or dissimilar, of any nature arising or resulting from the purchase, installation, removal, repair, operation, use or breakdown of the product(s) or any other cause whatsoever, including negligence.

The foregoing warranty shall also apply to products or parts which have been repaired or replaced pursuant to such warranty, and within the period of time, in accordance with Seller's stated warranty.

NO PERSON INCLUDING ANY AGENT OR REPRESENTATIVE OF EXLAR CORPORATION IS AUTHORIZED TO MAKE ANY REPRESENTATION OR WARRANTY ON BEHALF OF EXLAR CONCERNING ANY PRODUCTS MANUFACTURED BY EXLAR, EXCEPT TO REFER PURCHASERS TO THIS WARRANTY.

USA & CANADA

Exlar Automation
18400 West 77th Street
Chanhassen, MN 55317
Phone: 855-620-6200 (US & Canada)
Fax: 952-368-4877

EUROPE

Exlar Europe GmbH
Schleißheimer Str., 91a
Garching bei München D-85748
Germany
Phone: +49 6184 994730

ASIA

Exlar Asia Pacific
1007 Pine City Hotel
8 Dong An Road, Xuhui District
Shanghai 200032 China
Phone: +86 021-6495-7868

Distributed by:



www.exlar.com

Exlar® actuators are a brand of Curtiss-Wright, Actuation Division.