

ZTRS/ZTR/ZR rack and pinion drives

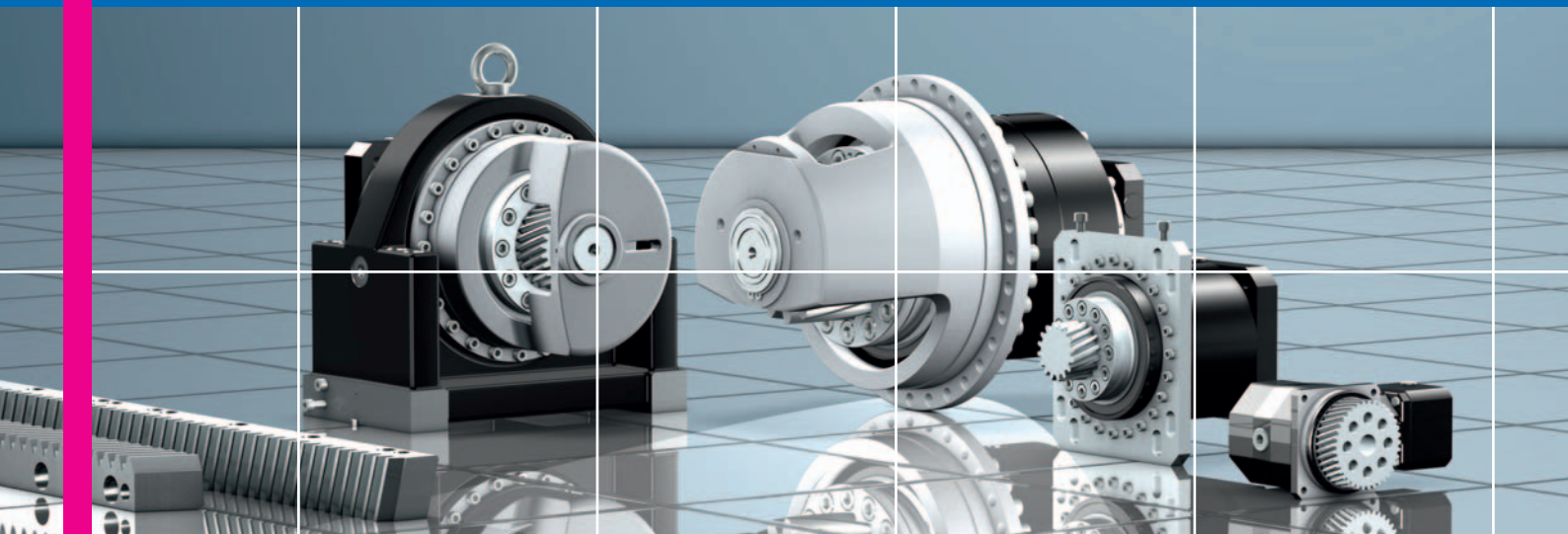

The highly efficient
rack and pinion drive with
innovative pinion bearing

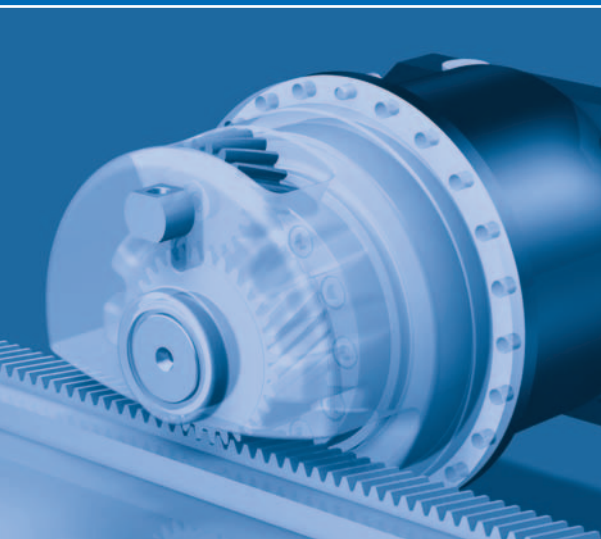

STÖBER

Drive optimisation for machine tool manufacture

The compact solution for more efficiency

In the past it was normal on rack and pinion drives to fit the pinion directly to a gear unit's flange shaft.

As a result of this single-sided pinion mounting, the very high tilting moment had to be absorbed by the bearings in the planetary gear unit. With the result that 'over-dimensioned' gear units with an abundant 'excess of torque' were required.

To be able to use smaller gear units with the torque actually required, the highly stiff supporting bearing module with integrated ZTRS pinion was developed.

This practical innovation is the result of an intensive exchange of experience between STOBER and the manufacturer of ATLANTA precision gear racks.



Rack and pinion drive with optional mounting bracket. Setting mechanism and felt wheel lubrication are integrated.

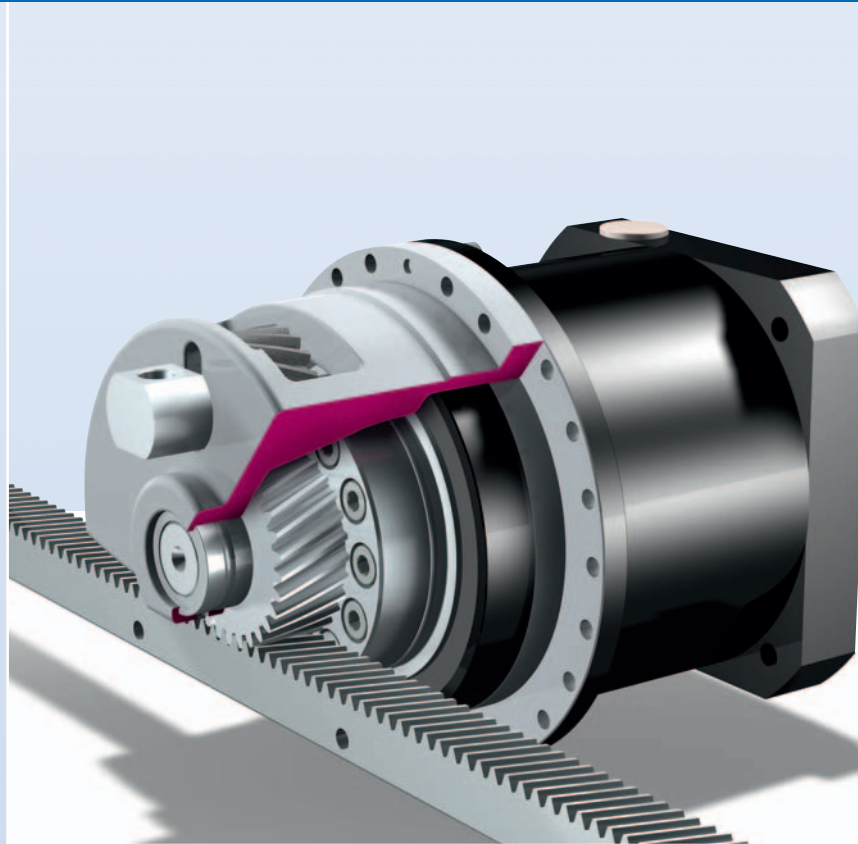

Rack and pinion drive ZTRS-PHA721.

Cast supporting bearing cover with ribbed internal contour for highest torsional stiffness.

The supporting bearing permits maximum feed forces, minimizes bending and increases the service life.

Housing cut-away above with optional felt lubrication pinion for the connection of a lubrication system or a central lubricator.

Highly stiff rack and pinion drive with supporting bearing

The cast supporting bearing cover with stiffening ribs as a supporting assembly forms a strong basis for the gear rack pinion. Pinion and cover are bolted to the housing and shaft flange of the PH(A) or PHV(A)/PHQ(A) gear unit series.

The additional supporting bearing brings about a very high drive tilting stiffness and also provides relief for the bearings of the planetary gear unit.

At the same time the cover serves as a protective housing and is used for mounting the optional lubrication device comprising a felt lubrication pinion running in parallel.

High power densities for high dynamic performance, smaller envelope, less costs

Due to this highly stiff design with reduced tilting moment, the tilting moment is no longer the key parameter on defining the drive (motor and gear unit) as in the past. The crucial criterion for defining the rack and pinion drive can now be orientated on the torque or the feed force actually required.

Because of these design enhancements a smaller gear unit, typically one size down, can be used compared to traditional designs with unilateral pinion bearings.

Along with the significantly increased power densities, other positive factors impress:

- Pinion concentricity adjusted to ≤ 0.01 mm (optional).
- Linear backlash reduced to $\sim 50\%$.
- Linear stiffness increased by $\sim 100\%$.
- Optimized adaptation of the mass moment by means of a large variety of gear unit ratios and numbers of pinion teeth.

Highly stiff rack and pinion drives as ready-to-

With helical geared planetary gear units

The ZTRS drives are based on the precision planetary gear units that are designed for very high requirements on torque as well as on torsional and tilting stiffness. The ratios range from $i = 4$ to $i = 121$ (up to 3 gear unit stages).

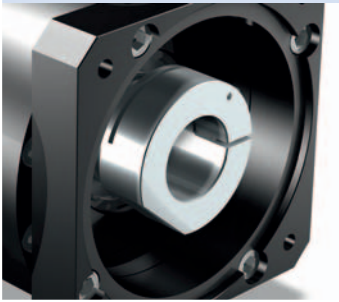

ME motor adapter for ZTRS-PH units with balanced EasyAdapt® motor coupling.

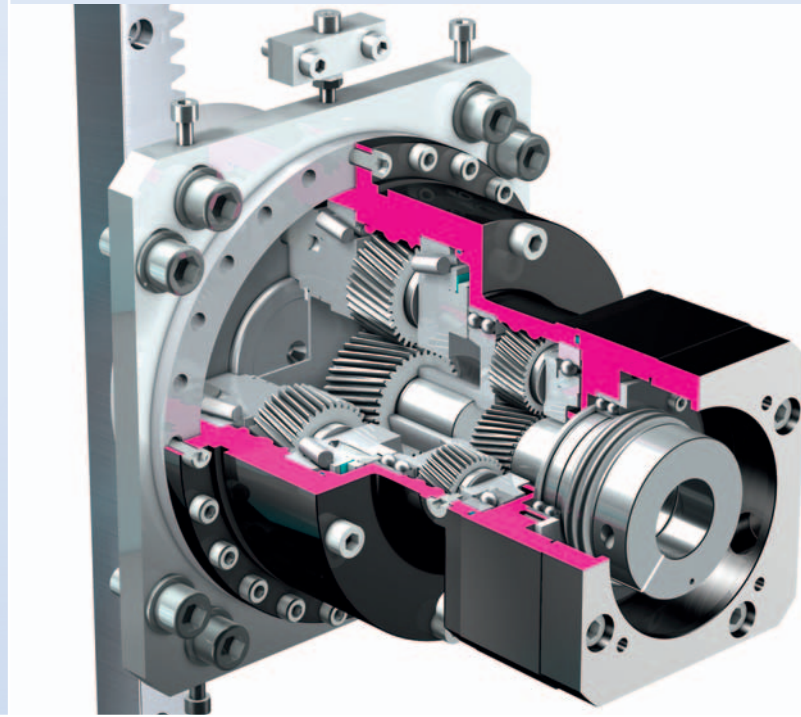



ZTRS_PHA822MF_MF
Rack and pinion drive, two-stage, with MF motor adapter and optional adjustment plate.

Balanced FlexiAdapt® clamp coupling for large motor shaft diameter with integrated thermal length compensation.

Helical geared rack drives for highest requirements. Feed force up to 126 kN

Due to the variability of gear unit types, sizes, ratios, number of pinion teeth and gear rack module, perfectly optimized rack and pinion drives for **machine tools** and **automation systems** are achieved. STOBER application consultants will be pleased to assist you with optimal design.

Overview rack and pinion drives

Designation	Types of gear units	Features	Accessories	Feed forces
ZTRS 	PH(A) 7 – 10 PHV(A) 9 + 10 PHQ(A) 10	Torque reducer pinion with supporting bearing cover helical geared and straight-cut, module $m=2$ to $m=10$ hardened and ground to quality level 5	Adjustment plate for PH(A) 7 – 9 Mounting bracket for PH(A) 8 + 9	16 kN to 124 kN
ZTR 	PH(A) 4 – 10 PHV(A) 9 + 10 KS4 – 7	Torque reducer pinion helical geared and straight-cut, module $m=2$ to $m=8$ hardened and ground to quality level 5	Adjustment plate for PH(A) 4 – 9 Mounting bracket for PH(A) 8 + 9	5.5 kN to 56 kN
ZR 	PH(A) 3 – 7 KS4 – 7	Large pinion with bolt circle holes helical geared, module $m=2$ to $m=4$ hardened and ground to quality level 5	Adjustment plate for PH(A) 3 – 7	1.7 kN to 12 kN

-install solutions

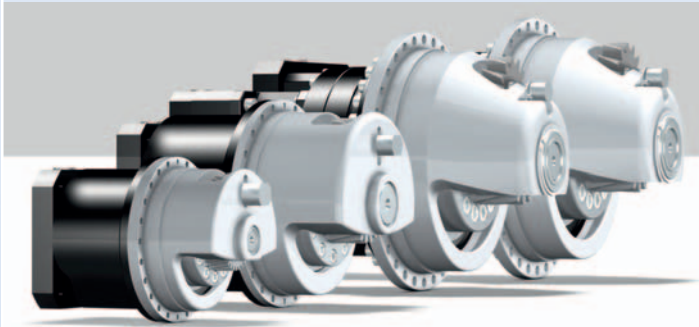

ZTRS-PH721
1 stage

ZTRS-PH821
1 stage

ZTRS-PH932
2 stage

ZTRS-PH1032
2 stage

Large or small pinion is no longer a question of mounting options

During the choice of the pinion size, the size of the pitch circle on the gear unit flange shaft no longer needs to be taken into account. Now pinions with the lowest possible number of teeth can be used as the linear stiffness of the rack and pinion drive increases by up to 100%.

The pinion size affects the linear stiffness

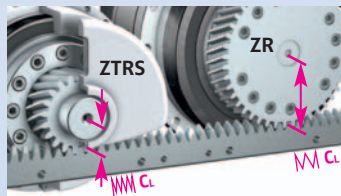
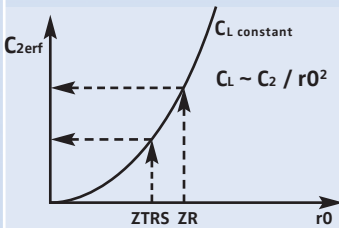

Linear stiffness through small lever arm.

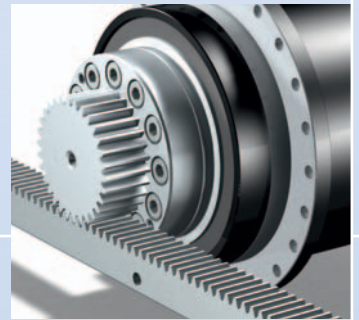

ZTR-PH with straight-cut flanged pinion.



Flanged pinion hardened and ground to quality level 5 acc. to DIN3960/3961.

Helical geared and straight-cut flanged pinions for use without and with output bearing housing.

The complete range for rack and pinion drives

For the ZTRS-PH(A)/PHV(A)/PHQ(A) and ZTR-PH(A)/PHV(A) rack and pinion drives STOBBER also supplies straight-cut flanged pinions.

For a limited torque requirement, the ZTR-PH version can be used with pinions with straight or inclined teeth without shaft ends.

Additionally, large-size helical-toothed pinions for bolt mounting without flange are available (ZR rack and pinion drive).

Perfectly matched components

The complete solution from a single source

Due to the close co-operation with the world market leader and manufacturer of ATLANTA precision gear racks, STOBER can offer comprehensive and uncompromisingly configured complete solutions.

The synergy effect of quality, precision and interaction of all components results in optimum functionality. As a result these rack and pinion drives are also suitable for the highest requirements.

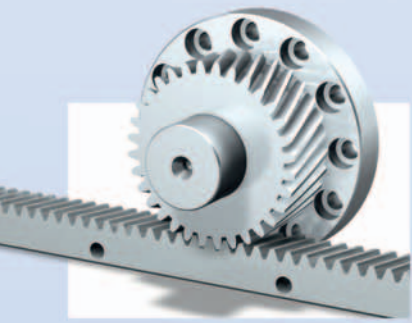

ATLANTA series 29

Gearing:

- Right-hand 19°31'42"
- Meshing angle 20°

Module 2 / 3 / 4 / 5 / 6 / 8 / 10 / 12

- Quality 5 and 6
- Teeth hardened and ground
- All sides ground

ATLANTA series 48

Gearing:

- Right-hand 19°31'42"
- Meshing angle 20°

Module 5 / 6 / 8 / 10 / 12

- Quality 4
- Teeth hardened and ground
- All sides ground

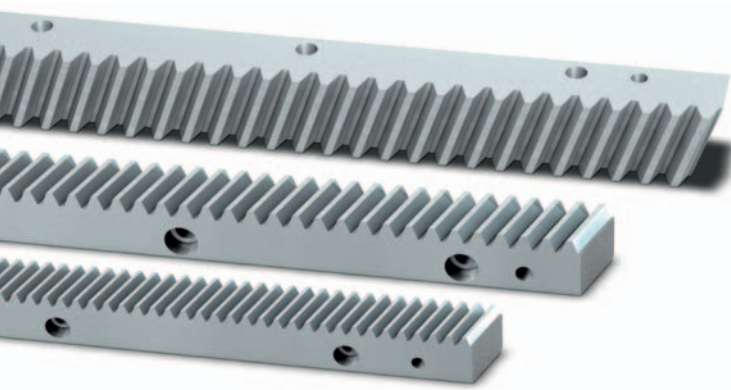

Precision gear racks
for assembly in series:
helical geared, Series 29,
Module 2 / 3 / 4 / 5 / 6 / 8 / 10 / 12

All precision racks are
also available in
straight-cut versions.

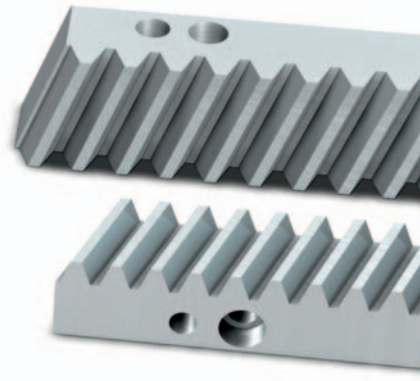

Precision gear racks
for assembly in series:
helical geared, Series 48,
Module 5 / 6 / 8 / 10 / 12

Adjustment plates and mounting brackets



The attachment options of the adjustment plates or mounting brackets are designed for setting the axial distance or the backlash without problem, particularly for rack and pinion drives.

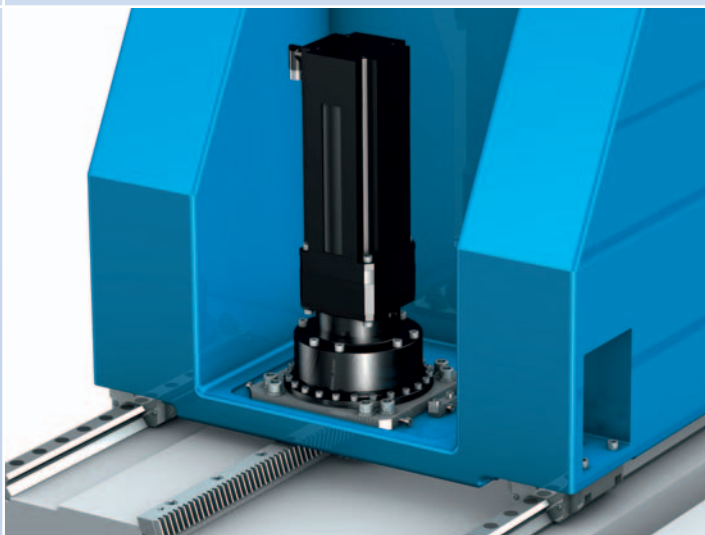

Service

The STÖBER service system includes 38 skilled partners in Germany and more than 80 organizations worldwide in the STÖBER SERVICE NETWORK.

STÖBER service specialists can be reached 24/7 and can support you with expertise and assistance if service is required on-site or guide you through appropriate immediate measures on the telephone.

24/7 service hotline
+49 180 5 786323

(14 cents/min. on German landline,
max. 42 cents/min. on mobile networks)

Note on the design of axes and drives

For optimum axis design, it makes sense to focus primarily on the gear units or geared motors. A useful aid is the design software SERVOfsoft®.

For an overall approach, use the specific expertise of the STÖBER application consultants.

Contact and advice:
applications@stoerber.de

STÖBER AUSTRIA
www.stoerber.at
+43 7613 7600-0
sales@stoerber.at

STÖBER CHINA
www.stoerber.cn
+86 10 6590 7391
sales@stoerber.cn

STÖBER FRANCE
www.stoerber.fr
+33 4 78.98.91.80
sales@stoerber.fr

STÖBER GERMANY
www.stoerber.de
+49 7231 582-0
sales@stoerber.de

STÖBER ITALY
www.stoerber.it
+39 02 93909570
sales@stoerber.it

STÖBER JAPAN
www.stoerber.co.jp
+81 3 5395 6788
sales@stoerber.co.jp

STÖBER SOUTH EAST ASIA
www.stoerber.sg
+65 65112912
sales@stoerber.sg

STÖBER SWITZERLAND
www.stoerber.ch
+41 56 496 96 50
sales@stoerber.ch

STÖBER TAIWAN
www.stoerber.tw
+886 2 2216 3428
sales@stoerber.tw

STÖBER TURKEY
www.stoerber.com
+90 212 338 80 14
sales-turkey@stoerber.com

STÖBER UNITED KINGDOM
www.stoerber.co.uk
+44 1543 458 858
sales@stoerber.co.uk

STÖBER USA
www.stoerber.com
+1 606 759 5090
sales@stoerber.com

www.stoerber.com

 **STÖBER**